

---

# OWNER'S MANUAL

---

## AIR POWERED CHAIN HOIST TCS SERIES

¼ Ton, ½ Ton and 1 Ton Capacity

Code, Lot and Serial Number

### **⚠ WARNING**

This equipment should not be installed, operated or maintained by any person who has not read and understood all the contents of this manual. Failure to read and comply with the contents of this manual can result in serious bodily injury or death, and/or property damage.

**HARRINGTON**  
HOISTS AND CRANES

# Table of Contents

<b>Section</b>	<b>Page Number</b>
1.0 Important Information and Warnings.....	4
1.1 Terms and Summary	
1.2 Warning Tags and Labels	
2.0 Technical Information.....	8
2.1 Specifications	
2.2 Dimensions	
2.3 Part Names	
3.0 Pre-operational Procedures.....	13
3.1 Air Supply System Requirements	
3.2 Air Supply Capacity And Regulation	
3.3 Lubrication	
3.4 Filtration	
3.5 Air Dryer	
3.6 Piping, Hoses And Fittings	
3.7 Mounting Location	
3.8 Connecting Hoist to Air Supply	
3.9 Mounting the Hoist	
3.10 Optional Chain Container	
3.11 Non-Stationary Application	
3.12 Preoperational Checks and Trial Operation	
4.0 Operation.....	21
4.1 Introduction	
4.2 Shall's and Shall Not's for Operation	
4.3 Hoist Controls	
4.4 Adjusting the Controls	
4.5 Speed Adjustment Controls	
4.6 Pendant Controllability Adjustment	

<b>Section</b>	<b>Page Number</b>
5.0 Inspection.....	27
5.1 General	
5.2 Inspection Classification	
5.3 Frequent Inspection	
5.4 Periodic Inspection	
5.5 Occasionally Used Hoists	
5.6 Inspection Records	
5.7 Inspection Methods and Criteria	
6.0 Lubrication.....	34
6.1 Air Hoist Lubrication	
6.2 Load Chain Lubrication	
6.3 Hooks and Suspension Components	
7.0 Maintenance & Handling.....	36
7.1 Brake	
7.2 Load Chain	
7.3 Pendant	
7.4 Load Sheave Inspection	
7.5 Storage	
7.6 Outdoor Installation	
8.0 Troubleshooting.....	42
9.0 Warranty.....	44
9.0 Parts Information.....	45

## 1.0 Important Information and Warnings

### 1.1 Terms and Summary

**This manual provides important information** for personnel involved with the installation, operation and maintenance of this product. Although you may be familiar with this or similar equipment, it is strongly recommended that you read this manual before installing, operating or maintaining the product.

**Danger, Warning, Caution and Notice** - Throughout this manual there are steps and procedures that can present hazardous situations. The following signal words are used to identify the degree or level of hazard seriousness.

**▲ DANGER** Danger indicates an imminently hazardous situation which, if not avoided, **will** result in **death or serious injury**, and property damage.

**▲ WARNING** Warning indicates an imminently hazardous situation which, if not avoided, **could** result in **death or serious injury**, and property damage.

**▲ CAUTION** Caution indicates a potentially hazardous situation which, if not avoided, **may** result **minor or moderate injury** or property damage.

**NOTICE** Notice is used to notify people of installation, operation, or maintenance information which is important but not directly hazard-related.

### ▲ CAUTION

These general instructions deal with the normal installation, operation, and maintenance situations encountered with the equipment described herein. The instructions should not be interpreted to anticipate every possible contingency or to anticipate the final system, crane, or configuration that uses this equipment. For systems using the equipment covered by this manual, the supplier and owner of the system are responsible for the system's compliance with all applicable industry standards, and with all applicable federal, state and local regulations/codes.

This manual includes instructions and parts information for a variety of hoist types. Therefore, all instructions and parts information may not apply to any one type or size of specific hoist. Disregard those portions of the instructions that do not apply.

Record your hoist's Code and Serial Number (see [Section 3.12.6](#) and [Figure 10-1](#)) on the front cover of this manual for identification and future reference to avoid referring to the wrong manual for information or instructions on installation, operation, inspection, maintenance, or parts.

Use only Harrington authorized replacement parts in the service and maintenance of this hoist.

## **WARNING**

Equipment described herein is not designed for and **MUST NOT** be used for lifting, supporting, or transporting people, or for lifting or supporting loads over people.

Equipment described herein should not be used in conjunction with other equipment unless necessary and/or required safety devices applicable to the system, crane, or application are installed by the system designer, system manufacturer, crane manufacturer, installer, or user.

Modifications to upgrade, rerate, or otherwise alter this equipment shall be authorized only by the original equipment manufacturer.

Equipment described herein may be used in the design and manufacture of cranes or monorails. Additional equipment or devices may be required for the crane and monorail to comply with applicable crane design and safety standards. The crane designer, crane manufacturer, or user is responsible to furnish these additional items for compliance. Refer to ANSI/ASME B30.17, "Safety Standard for Top-Running Single Girder Cranes"; ANSI/ASME B30.2 "Safety Standard for Top-Running Double-Girder Cranes"; and ANSI/ASME B30.11 "Safety Standard for Underhung Cranes and Monorails".

If a below-the-hook lifting device or sling is used with a hoist, refer to ANSI/ASME B30.9, "Safety Standard for Slings" or ANSI/ASME B30.20, "Safety Standard for Below-the-Hook Lifting Devices".

Hoists, trolleys and cranes, used to handle hot molten material may require additional equipment or devices. Refer to ASTM-E-2349, "Standard for Safety Requirements in Metal Casting: Sand Preparation, Molding, and Core Making; Melting and Pouring; and Cleaning and Finishing".

Failure to read and comply with any one of the limitations noted herein can result in serious bodily injury or death, and/or property damage.

## **DANGER**

**HAZARDOUS AIR PRESSURE IS PRESENT IN THE HOIST, IN THE SUPPLY OF COMPRESSED AIR TO THE HOIST, AND IN THE CONNECTIONS BETWEEN COMPONENTS.**

Before performing ANY maintenance on the equipment, de-energize the supply of compressed air to the equipment, and lock and tag the supply device in the de-energized position. Refer to ANSI Z244.1, "Personnel Protection - Lockout/Tagout of Energy Sources."

Only trained and competent personnel should inspect and repair this equipment.

## **NOTICE**

It is the responsibility of the owner/user to install, inspect, test, maintain, and operate a hoist in accordance with ANSI/ASME B30.16, "Safety Standard for Overhead Hoists", OSHA Regulations. If the hoist is installed as part of a total lifting system, such as an overhead crane or monorail, it is also the responsibility of the owner/user to comply with the applicable ANSI/ASME B30 volume that addresses that type of equipment.

It is the responsibility of the owner/user to have all personnel that will install, inspect, test, maintain, and operate a hoist read the contents of this manual and applicable portions of ANSI/ASME B30.16, "Safety Standard for Overhead Hoists" and OSHA Regulations. If the hoist is installed as part of a total lifting system, such as an overhead crane, the applicable ANSI/ASME B30 volume that addresses that type of equipment must also be read by all personnel.

If the hoist owner/user requires additional information, or if any information in the manual is not clear, contact Harrington or the distributor of the hoist. Do not install, inspect, test, maintain, or operate this hoist unless this information is fully understood.

A regular schedule of inspection of the hoist in accordance with the requirements of ANSI/ASME B30.16 should be established and records maintained.

## 1.2 Warning Tags and Labels

The warning tag illustrated below in [Figure 1-1](#) is supplied with each hoist shipped from the factory. If the tag is not attached to your hoist (for pendant control, the warning tag is attached to the pendant hose; for the pull cord control, the warning tag is attached to the up cord), order a tag from your dealer and install it. See parts list in the parts section of this manual. Read and obey all warnings attached to this hoist. Tag is not shown actual size.

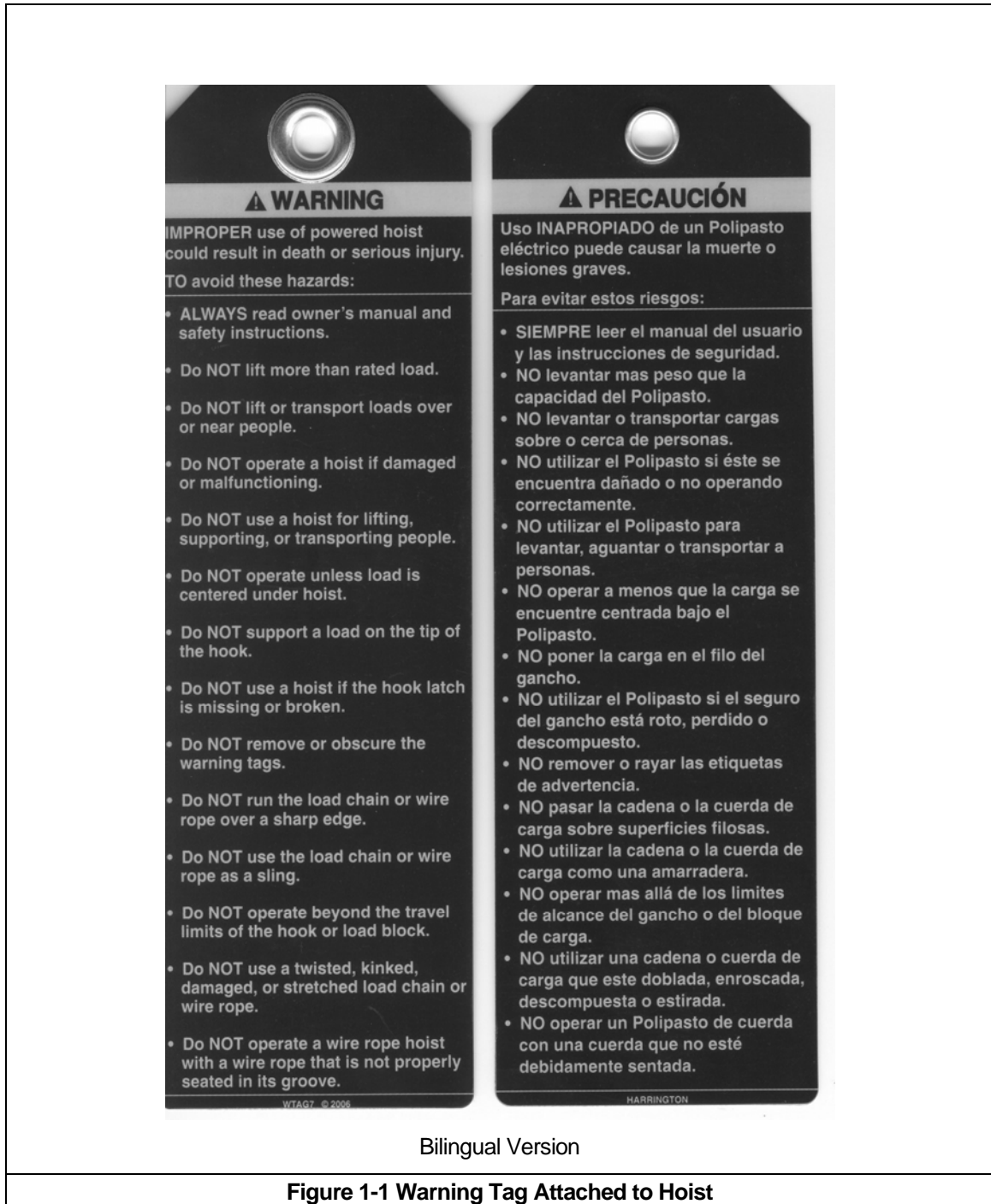

## 2.0 Technical Information

### 2.1 Specifications

#### 2.1.1 Product Code

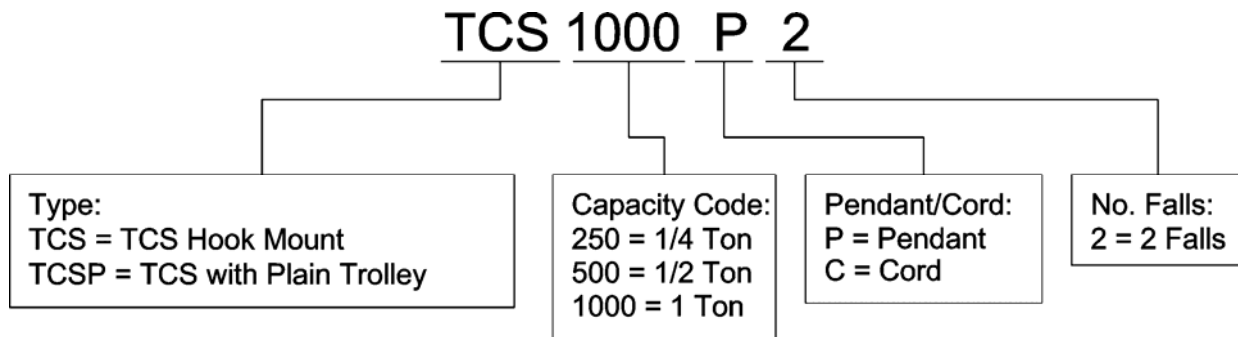

#### 2.1.2 Operating Conditions and Environment

Temperature range: +14° to +140°F (-10° to +60°C)

Relative Humidity: 85% or less

Noise Level: 83 dba maximum @ 1 meter when lifting rated load  
93 dba maximum @ 1 meter when lowering rated load

Supply Air: 60 to 90 psi (0.4 to 0.6 MPa)

Air Consumption: 60 to 75 cfm (1.7 to 2.1 m<sup>3</sup>/min)

Air Lubrication Requirements: Minimum 10 to 15 drops per minute (2-3 cc/min) of oil

Air Filtration Requirements: Maximum 5 micron air filter or finer

**Table 2-1 Hoist Specifications**

	Cap. (Tons)	Product Code	Standard Lift (ft)	Push Button Hose L (ft)	Up/Down Speeds (ft/min @ 90 psi)		Up/Down Air Consumption Rates (cubic ft/min @ 90 psi)		Load Chain Diameter (mm) x Chain Fall Lines	Net Weight (lbs)	Weight for Additional One foot of Lift (lbs)
					No Load	w/Full Load	No Load	w/Full Load			
					Pendant Model	1/4	TCS250P	10			
1/2	TCS500P	8.1	108/62	60/108		74/64	60/71		6.3 X 1	42	0.9
1	TCS1000P2	8.1	54/31	30/54		74/64	60/71		6.3 x 2	55	1.2
Cord Model	1/4	TCS250C	10	7.3	207/125	112/197	78/67	64/74	6.3 X 1	40	0.6
	1/2	TCS500C		7.3	108/62	60/108	74/64	60/71	6.3 X 1	40	0.9
	1	TCS1000C2		7.3	54/31	30/54	74/64	60/71	6.3 x 2	53	1.2

## 2.2 Dimensions

Table 2-2 TCR with Pendant Control Dimensions										
<p>Single Fall Hoist</p>			<p>Double Fall Hoist</p>							
Cap. (Tons)	Product Code	Headroom C (in)	a (in)	b (in)	d (in)	e (in)	g (in)	h (in)	i (in)	j (in)
1/4	TCS250P	16.3	14.4	8.7	6.3	7.6	1.0	5.3	3.3	1.0
1/2	TCS500P	16.3	14.4	8.7	6.3	7.6	1.0	5.3	3.3	1.0
1	TCS1000P2	17.9	14.4	9.0	6.3	8.0	1.1	6.3	2.8	1.9

**Table 2-3 TCR with Cord Control Dimensions**

Cap. (Tons)	Product Code	Headroom C (in)	a (in)	b (in)	d (in)	e (in)	g (in)	h (in)	i (in)	j (in)
1/4	TCS250C	16.3	14.4	8.7	6.3	7.6	1.0	5.3	3.3	1.0
1/2	TCS500C	16.3	14.4	8.7	6.3	7.6	1.0	5.3	3.3	1.0
1	TCS1000C2	17.9	14.4	9.0	6.3	8.0	1.1	6.3	2.8	1.9

**Table 2-4 Top and Bottom Hook Dimension\***

Units = inch

Product Code	a	b	c	d	e	f	g	h
TCS250C/P	0.6	0.8	0.6	0.8	1.4	1.3	1.0	2.9
TCS500C/P	0.6	0.8	0.6	0.8	1.4	1.3	1.0	2.9
TCS1000C2/P2	1.4	0.9	1.1	0.9	1.6	1.6	1.1	4.2

\*Refer to Section 5.7 for inspection dimensions and limits.

## 2.3 Part Names

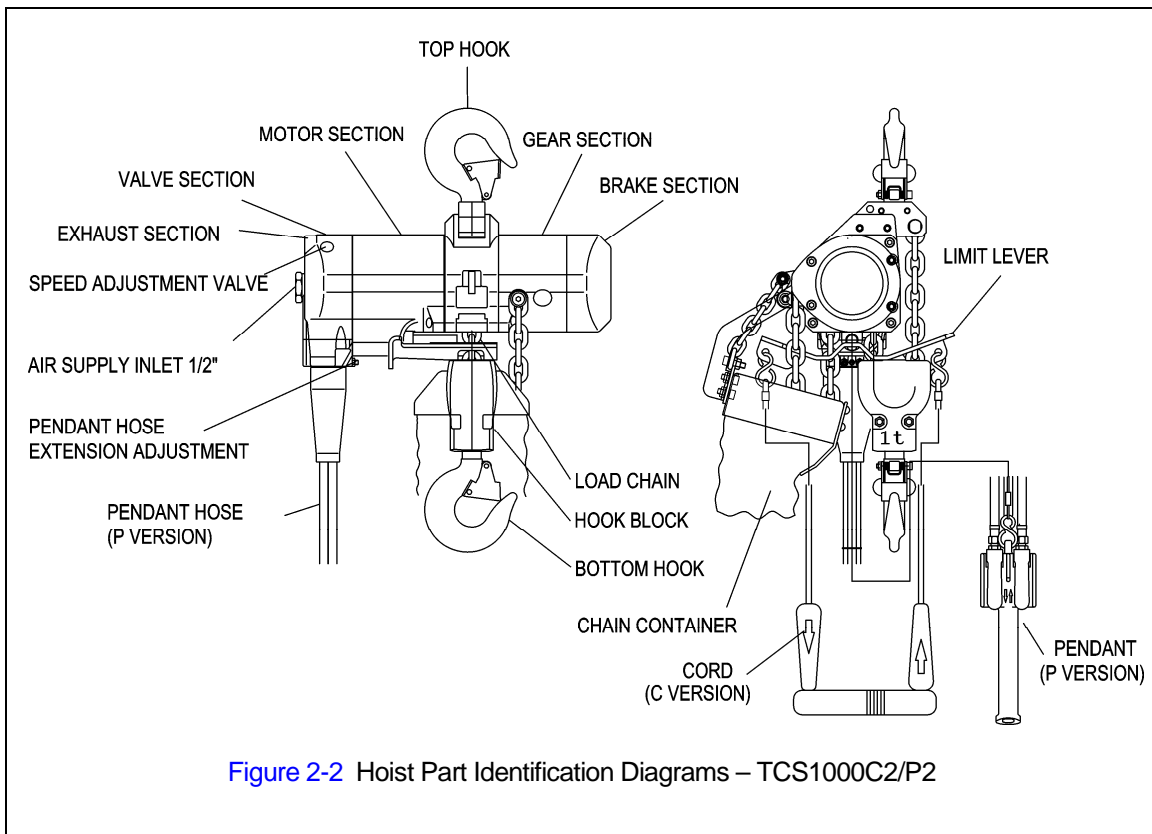
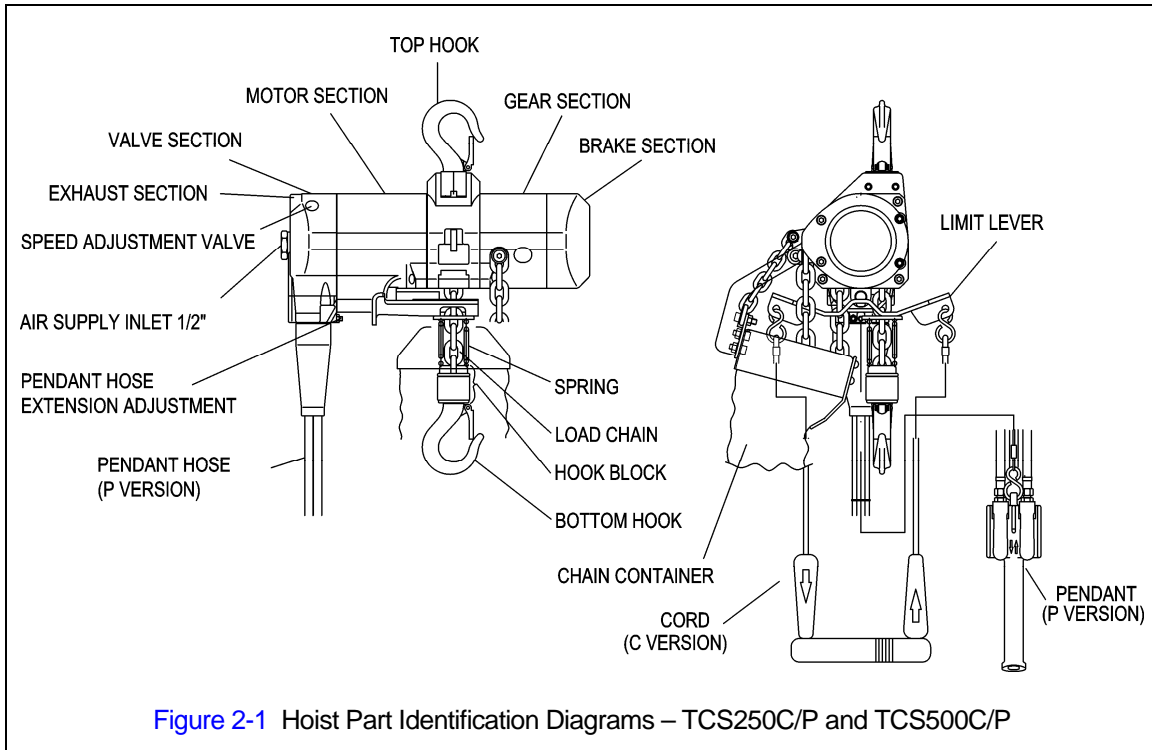

## 3.0 Preoperational Procedures

### 3.1 Air Supply System Requirements

- 3.1.1 **NOTICE** Pressure and Flow - Verify that the air supply system has capacity to supply your air hoist with required pressure and flow. Otherwise the hoist may operate poorly or may fail to operate. See [Section 3.2](#).
- 3.1.2 **CAUTION** Lubrication - The hoist requires lubrication for proper operation. The oil in the air supply is the primary source of lubrication to the hoist. Therefore, a dedicated air supply lubricator must be used with the hoist. Refer to [Section 3.3](#).
- 3.1.3 **CAUTION** Air Quality - Good air quality is essential to prevent damage to your hoist and to ensure its proper operation. The air must be clean and free of debris such as dirt and rust. Refer to [Section 3.4](#) for filtration requirements. The air must also be dry; free of moisture and water. Refer to [Section 3.5](#).

### 3.2 Air Supply Capacity And Regulation

- 3.2.1 Capacity - The air supply system must be capable of delivering the required airflow (cfm) to the hoist inlet port. Without the required airflow the hoist will not operate properly or may not operate at all. See [Section 2.0](#) for your hoists air consumption requirements. In determining if your system is capable of supplying the required airflow, consider the following:
- Capacity of compressor(s) and tank
  - Other air consuming equipment
  - Flow restrictions such as pipes, hoses, valves and fittings
- Inadequate capacity will cause a significant drop in pressure when the hoist is operated, and could cause poor performance or failure to operate.
- 3.2.2 Regulation - The hoist requires a constant supply of air at a pressure of between 60 and 90 psi. If the air supply is not regulated or is regulated at a pressure greater than 90 psi, then a regulator must be used. The regulator may be located anywhere upline of the lubricator in the air supply to the hoist.

### 3.3 Lubrication

- 3.3.1 **CAUTION** The hoist must be supplied with its own lubricator. The lubricator must be located as follows:
- 1) **Best location** - At the hoist inlet. In this case the lubricator can be either the mist type or drop type.
  - 2) **Second best location** - No more than 15 feet away from the hoist, at the same elevation or above the hoist inlet. In this case the mist type lubricator must be used.
  - 3) **Third best location** - No more than 15 feet away below the hoist. In this case the mist type lubricator must be used.
- 3.3.2 **CAUTION** The lubricator must be set to deliver the equivalent of 10 to 15 drops of oil per minute (2 to 3 cc/minute). The hoist's exhaust will emit a fine oil mist when properly lubricated.

### 3.4 Filtration

- 3.4.1 **CAUTION** The air entering the hoist inlet must not contain any particulate greater than 5 microns in size. Therefore, the hoist must have a 5 micron filter in its air supply. The filter must be upstream of the lubricator.

3.4.2 The filter servicing the hoist can also service other hoists and air consuming equipment. In this case, the air filter must be in sized for the total air consumption of the equipment it is servicing.

**3.5 Air Dryer - ⚠ CAUTION** To prevent corrosion and hoist malfunction, employ an air dryer in the air supply system to ensure that dry air is supplied to the hoist. If there is moisture in the air supplied to the hoist, this moisture will cause corrosion on internal hoist components during periods when the hoist is idle leading to hoist malfunction.

### 3.6 Piping, Hoses And Fittings

3.6.1 **⚠ CAUTION** System Configuration - The system should be configured as shown in [Figure 3-1](#). Since moisture tends to accumulate in compressed air systems, corrosion may result if the system is not periodically drained.

- Arrange for a drain in the air supply piping at the lowest point in the piping, and
- Periodically drain the system to remove moisture/water from the system and to prevent corrosion.
- Filter, regulator (if equipped), and lubricator must be arranged in the order shown in [Figure 3-2](#).

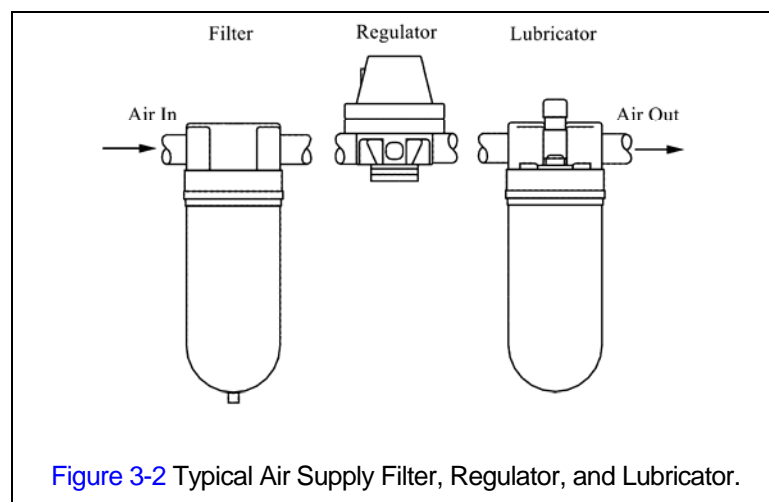
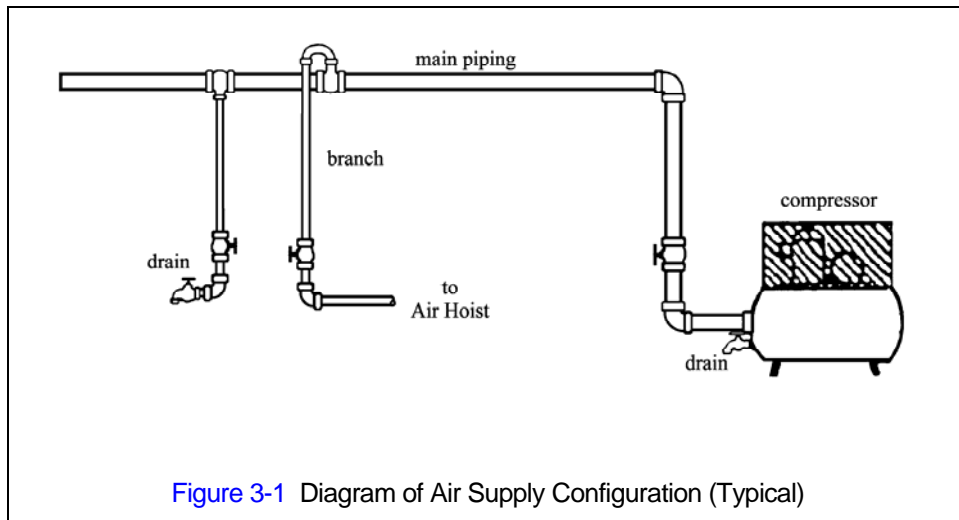

- 3.6.2 **NOTICE** Piping - Pipe should be sized to accommodate the hoist airflow requirements. [Table 3-1](#) gives recommended pipe sizes.

Table 3-1 Air Supply Pipe and Hose Sizes		
Model	Diameter of Supply Pipe	Diameter of Supply Hose
TCS250C/P TCS500C/P TCS1000C2/P2	Inside diameter 3/4" or larger	Inside diameter 1/2" or larger

- 3.6.3 **NOTICE** Hoses - The connection from the air supply system piping to the hoist must be made with a flexible pressure hose. Due to normal line losses in air supply lines:

- Do not use hose smaller than specified in [Table 3-1](#), and
- Limit the length of the hose to that specified in [Figure 3-3](#).

If your application exceeds these requirements consult factory.

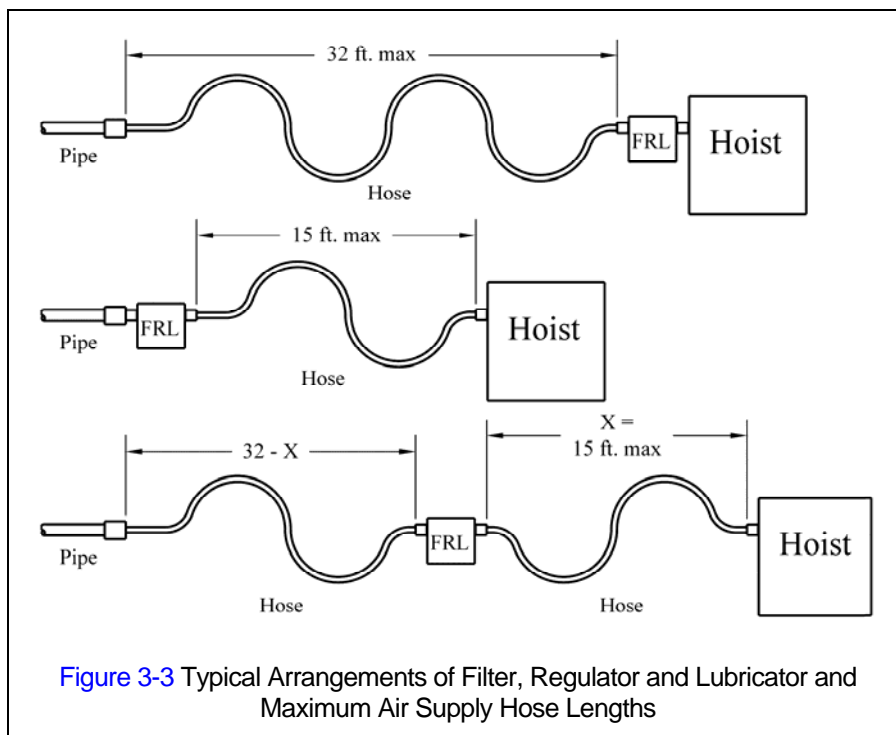

- 3.6.4 **CAUTION** Fittings - Important considerations regarding fittings in the hoist's air supply include:
- When connecting air supply components, remove all dirt or debris from the connecting surfaces of the hoses, pipes, fittings, or threaded fasteners to prevent contaminants from entering the hoist.
  - Keep airflow restrictions such as quick disconnect fittings, bends, elbows, and adapters to a minimum.
- 3.6.5 **CAUTION** Before connecting the hoist to its air supply line; perform the proper draining and purging procedures to prevent contaminants or moisture from entering the hoist.

### 3.7 Mounting Location

3.7.1 **⚠ WARNING** Prior to mounting the hoist ensure that the suspension and its supporting structure are adequate to support the hoist and its loads. If necessary consult a professional that is qualified to evaluate the adequacy of the suspension location and its supporting structure.

3.7.2 **NOTICE** See [Section 7.6](#) for outdoor installation considerations.

### 3.8 Connecting Hoist to Air Supply

3.8.1 **⚠ WARNING** HAZARDOUS AIR PRESSURE IS PRESENT IN THE HOIST, IN THE SUPPLY OF COMPRESSED AIR TO THE HOIST, AND IN THE CONNECTIONS BETWEEN COMPONENTS.

3.8.2 Shut off the air supply and stop the airflow completely. Lock out and tag out in accordance with ANSI Z244.1 "Personnel Protection -Lockout/Tagout of Energy Sources".

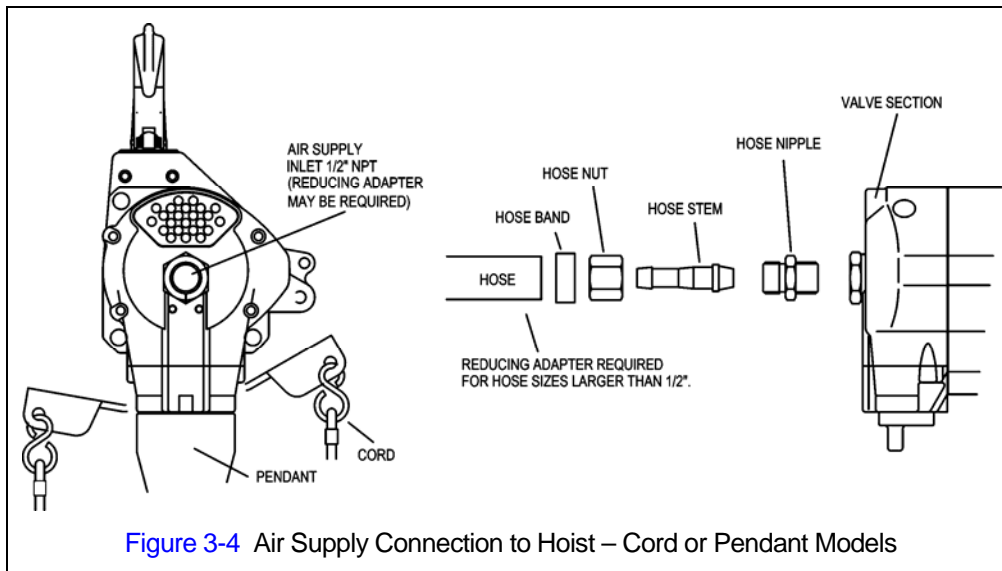

3.8.3 **⚠ CAUTION** Before connecting the air supply hose to the hoist, always purge the air hose to clear any debris and water.

3.8.4 Apply approximately 10-15 drops of turbine oil (see approved lubricant under [Section 6.0](#) Lubricants) into the hose before attaching to the hoist.

3.8.5 Make connections to air supply; reference [Figure 3-4](#). Use a reducing adapter at the hoist valve section for hose sizes larger than 1/2".

3.8.6 **NOTICE** Where conditions dictate, the installation sequence can be reversed by mounting the hoist first ([Section 3.9](#)) followed by connecting the air supply.

### 3.9 Mounting the Hoist

3.9.1 Manual Trolley - Follow instructions in Owner's Manual provided with the trolley.

3.9.2 Hook Mounted to a Fixed Location - Attach the hoist's top hook to the fixed suspension point.

3.9.3 **⚠ WARNING** Ensure that the fixed suspension point rests on the center of the hook's saddle and that the hook's latch is engaged.

### 3.10 Optional Chain Container

3.10.1 Follow instructions below to install the optional chain container. Refer to [Figure 3-5](#).

- 1) Attach the metal bracket on top of the chain container to the lower boss on the side of the hoist body using the M8 Socket Bolt, Washers, Nut and Split Pin provided.
- 2) Attach the support chain to the upper boss on the side of the hoist body using the M6 Socket Bolt, Washers, Nut and Split Pin provided.
- 3) Make sure all fasteners on the chain container and chain attachment points are secure and that the split pins are sufficiently bent.
- 4) Feed the Chain into the Chain Container beginning with the no-load end. Take care to avoid twisting or tangling the Chain.
- 5) **⚠ CAUTION** Do not use the Chain Container if any parts are damaged or if any fasteners/hardware are missing.

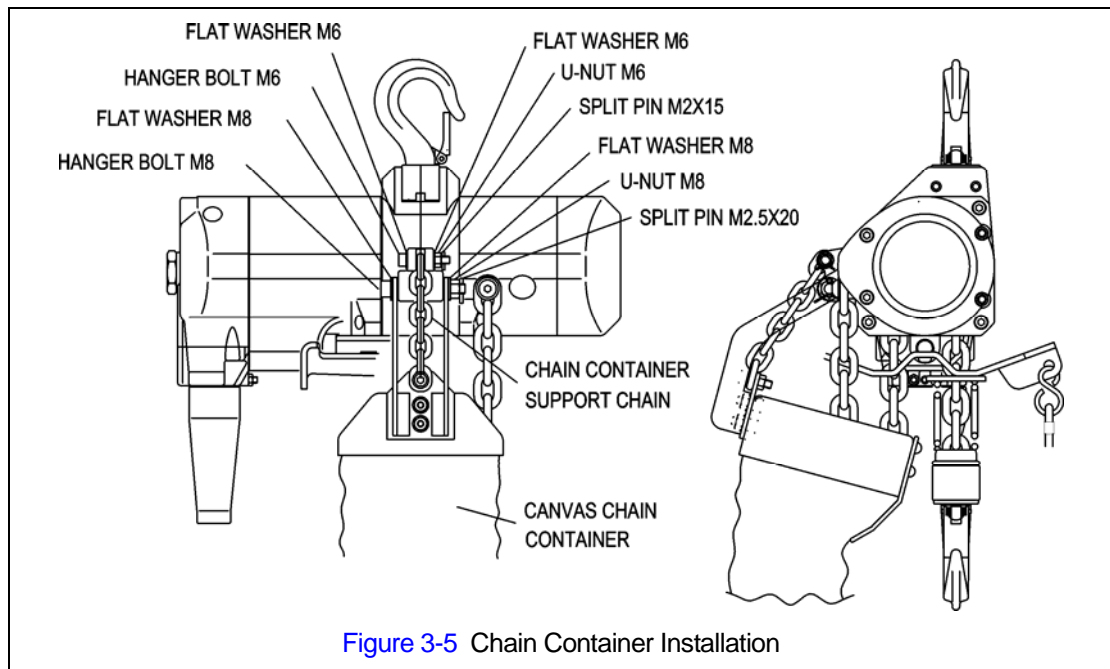

Figure 3-5 Chain Container Installation

### 3.11 Non-Stationary Application

- 3.11.1 For applications such as rental fleets or construction sites where the hoist is moved from place-to-place, a filter and lubricator are still required. Consult factory for recommended methods.
- 3.11.2 Connections and fittings must be kept clean and care taken to prevent dirt, debris and moisture from entering the hoist.
- 3.11.3 Recommended practice for removing the hoist from an installation:
  - 1) Run the hoist briefly with well lubricated air
  - 2) Shut off the air supply to the hoist, bleed off any pressure in the system then disconnect the air supply line.
  - 3) Inject a small quantity (approximately 20 drops) of turbine oil (see [Section 6.0](#)) into the hoist's inlet port
  - 4) Plug the inlet port

### 3.12 Preoperational Checks and Trial Operation

3.12.1 **⚠ CAUTION** Check for the availability of required operating air pressure of between 60 psi to 90 psi at the hoist's inlet port before trying to operate the hoist.

3.12.2 **⚠ WARNING** Verify that the load chain is not twisted or tangled and that the bottom hook is not capsized prior to operating the hoist. Correct all chain irregularities before conducting the first hoist operation. See [Figures 3-6](#) and [3-7](#).

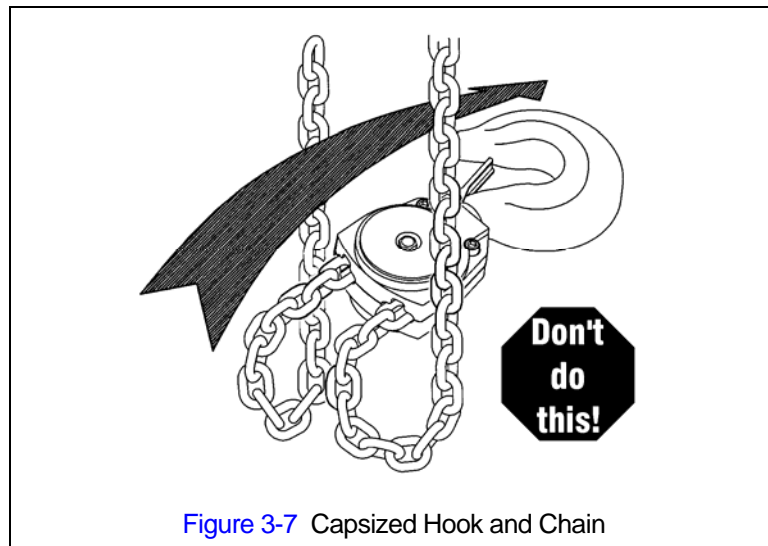
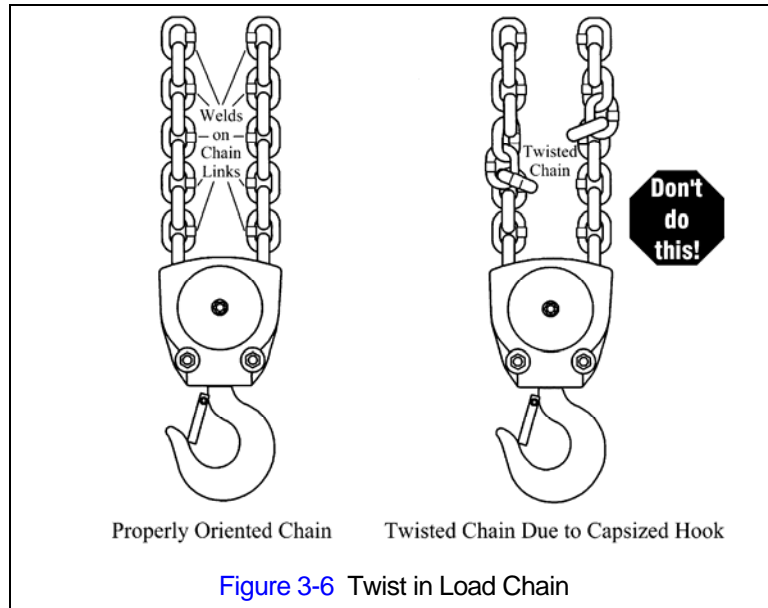

3.12.3 **⚠ WARNING** Confirm the adequacy of the rated capacity for all slings, chains, wire ropes and all other lifting attachments before use. Inspect all load suspension members for damage prior to use and replace or repair all damaged parts.

- 3.12.4 **⚠ WARNING** Verify that the Chain/Limit Lever is operational and can move freely in both the up and down directions. For reference see [Figure 3-8](#).

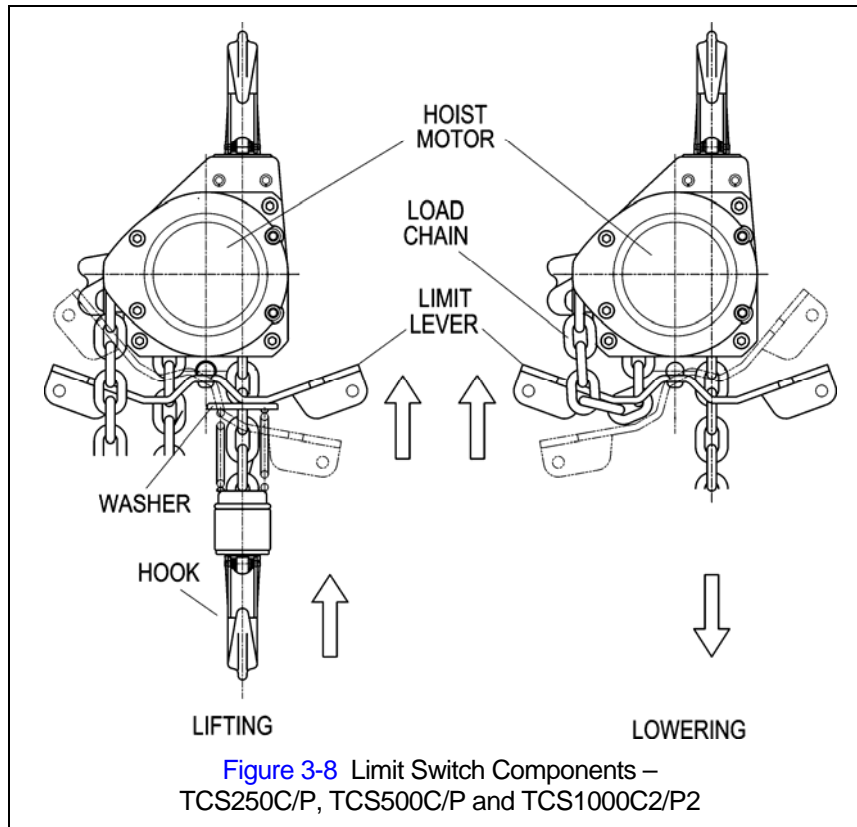

- 3.12.5 Measure and record the “K” dimension of all hooks on hoist. See [Table 5-6](#) under [Section 5](#), “Inspection”. Always use the same side of the hook to measure and record the “K” dimension.
- 3.12.6 Record the hoist Code Number and Serial Number (from the nameplate on the hoist – see [Section 10](#)) in the space provided on the cover of this manual.
- 3.12.7 Ensure that the hoist is properly installed to either a fixed point, or trolley, whichever applies.
- 3.12.8 If hoist is installed on a trolley, ensure that
- trolley is properly installed on the beam, and
  - stops for the trolley are correctly positioned and securely installed on the beam.
- 3.12.9 Ensure that all nuts, bolts and split (cotter) pins are sufficiently fastened.
- 3.12.10 For hoists with pendant controls, ensure that the Pendant Hoses and Strain Relief wire are properly attached to the hoist. See [Section 7.4](#).
- 3.12.11 **⚠ CAUTION** Check Air Supply - Check air supply before everyday use. Ensure proper air quality and air pressure.
- 3.12.12 **⚠ CAUTION** Check the lubricator for proper function and adequate oil level.

3.12.13 Confirm proper operation.

- Before operating read and become familiar with [Section 4 - Operation](#).
- Before operating ensure that the hoist (and trolley) meets the Inspection, Testing and Maintenance requirements of ANSI/ASME B30.16.
- Before operating ensure that nothing will interfere with the full range of the hoist's (and trolley's) operation.

3.12.4 Proceed with trial operation to confirm proper operation.

- **⚠ CAUTION** Make sure hook travel is in the same direction as shown on controls.
- Initially operate slowly under no load in both directions. Verify controls agree with hoist direction.
- Perform inspections per [Section 5.3](#), "Frequent Inspections".

## 4.0 Operation

### 4.1 Introduction

#### **DANGER**

DO **NOT** WALK UNDER A SUSPENDED LOAD

#### **WARNING**

HOIST OPERATORS SHALL BE REQUIRED TO READ THE OPERATION SECTION OF THIS MANUAL, THE WARNINGS CONTAINED IN THIS MANUAL, INSTRUCTION AND WARNING LABELS ON THE HOIST OR LIFTING SYSTEM, AND THE OPERATION SECTIONS OF ANSI/ASME B30.16 and ANSI/ASME B30.10. THE OPERATOR SHALL ALSO BE REQUIRED TO BE FAMILIAR WITH THE HOIST AND HOIST CONTROLS BEFORE BEING AUTHORIZED TO OPERATE THE HOIST OR LIFTING SYSTEM.

HOIST OPERATORS SHOULD BE TRAINED IN PROPER RIGGING PROCEDURES FOR THE ATTACHMENT OF LOADS TO THE HOIST HOOK.

HOIST OPERATORS SHOULD BE TRAINED TO BE AWARE OF POTENTIAL MALFUNCTIONS OF THE EQUIPMENT THAT REQUIRE ADJUSTMENT OR REPAIR, AND TO BE INSTRUCTED TO STOP OPERATION IF SUCH MALFUNCTIONS OCCUR, AND TO IMMEDIATELY ADVISE THEIR SUPERVISOR SO CORRECTIVE ACTION CAN BE TAKEN.

HOIST OPERATORS SHOULD HAVE NORMAL DEPTH PERCEPTION, FIELD OF VISION, REACTION TIME, MANUAL DEXTERITY, AND COORDINATION.

HOIST OPERATORS SHOULD **NOT** HAVE A HISTORY OF OR BE PRONE TO SEIZURES, LOSS OF PHYSICAL CONTROL, PHYSICAL DEFECTS, OR EMOTIONAL INSTABILITY THAT COULD RESULT IN ACTIONS OF THE OPERATOR BEING A HAZARD TO THE OPERATOR OR TO OTHERS.

HOIST OPERATORS SHOULD **NOT** OPERATE A HOIST OR LIFTING SYSTEM WHEN UNDER THE INFLUENCE OF ALCOHOL, DRUGS, OR MEDICATION.

OVERHEAD HOISTS ARE INTENDED ONLY FOR VERTICAL LIFTING SERVICE OF FREELY SUSPENDED UNGUIDED LOADS. DO **NOT** USE HOIST FOR LOADS THAT ARE NOT LIFTED VERTICALLY, LOADS THAT ARE NOT FREELY SUSPENDED, OR LOADS THAT ARE GUIDED.

#### **NOTICE**

- Read ANSI/ASME B30.16 and ANSI/ASME B30.10.
- Read the hoist manufacturer's Operating and Maintenance Instructions.
- Read all labels attached to equipment.

The operation of an overhead hoist involves more than activating the hoist's controls. Per the ANSI/ASME B30 standards, the use of an overhead hoist is subject to certain hazards that cannot be mitigated by engineered features, but only by the exercise of intelligence, care, common sense, and experience in anticipating the effects and results of activating the hoist's controls. Use this guidance in conjunction with other warnings, cautions, and notices in this manual to govern the operation and use of your overhead hoist.

## 4.2 Shall's and Shall Not's for Operation

### **WARNING**

Improper operation of a hoist can create a potentially hazardous situation which, if not avoided, could result in death or serious injury, and substantial property damage. To avoid such a potentially hazardous situation **THE OPERATOR SHALL:**

- **NOT** operate a damaged, malfunctioning or unusually performing hoist.
- **NOT** operate a hoist until you have thoroughly read and understood Manufacturer's Operating and Maintenance Instructions or Manuals.
- Be familiar with operating controls, procedures, and warnings.
- **NOT** operate a hoist that has been modified without the manufacturer's approval or without certification that it is in conformity with ANSI/ASME B30 volumes.
- **NOT** lift more than rated load for the hoist.
- **NOT** use hoist with twisted, kinked, damaged, or worn wire rope.
- **NOT** use the hoist to lift, support, or transport people.
- **NOT** lift loads over people.
- **NOT** operate a hoist unless all persons are and remain clear of the supported load.
- **NOT** operate unless load is centered under hoist.
- **NOT** attempt to lengthen the load wire rope or repair damaged load wire rope.
- Protect the hoist's load wire rope from weld splatter or other damaging contaminants.
- **NOT** operate hoist when it is restricted from forming a straight line from hook to support in the direction of loading.
- **NOT** use load wire rope as a sling or wrap load wire rope around load.
- **NOT** apply the load to the tip of the hook or to the hook latch.
- **NOT** apply load unless the wire rope is properly seated in its grooves.
- **NOT** apply load if bearing prevents equal loading on all load-supporting ropes.
- **NOT** operate beyond the limits of the load wire rope travel.
- **NOT** leave load supported by the hoist unattended unless specific precautions have been taken.
- **NOT** allow the load wire rope or hook to be used as an electrical or welding ground.
- **NOT** allow the load wire rope or hook to be touched by a live welding electrode.
- **NOT** remove or obscure the warnings on the hoist.
- **NOT** operate a hoist on which the safety placards or decals are missing or illegible
- **NOT** operate a hoist unless it has been securely attached to a suitable support.
- **NOT** operate a hoist unless load slings or other approved single attachments are properly sized, and seated in the hook saddle.
- **NOT** use the hoist in such a way that could result in shock or impact loads being applied to the hoist.
- Take up slack carefully – make sure load is balanced and load-holding action is secure before continuing.
- Shut down a hoist that malfunctions or performs unusually and report such malfunction.
- Make sure hoist limit switches function properly.
- Warn personnel before lifting or moving a load.
- Warn personnel of an approaching load.

## **⚠ CAUTION**

Improper operation of a hoist can create a potentially hazardous situation which, if not avoided, could result in minor or moderate injury, or property damage. To avoid such a potentially hazardous situation **THE OPERATOR SHALL:**

- Maintain a firm footing or be otherwise secured when operating the hoist.
- Check brake function by tensioning the hoist prior to each lift operation.
- Use hook latches. Latches are to retain slings, chains, etc. under slack conditions only.
- Make sure the hook latches are closed and not supporting any parts of the load.
- Make sure the load is free to move and will clear all obstructions.
- Avoid swinging the load or hook.
- Make sure hook travel is in the same direction as shown on controls.
- Inspect the hoist regularly, replace damaged or worn parts, and keep appropriate records of maintenance.
- Use the hoist manufacturer's recommended parts when repairing the unit.
- Lubricate load chain per hoist manufacturer's recommendations.
- **NOT** use the hoist load limiting or warning device to measure load.
- **NOT** use limit switches as routine operating stops. They are emergency devices only.
- **NOT** allow your attention to be diverted from operating the hoist.
- **NOT** allow the hoist to be subjected to sharp contact with other hoists, structures, or objects through misuse.
- **NOT** adjust or repair the hoist unless qualified to perform such adjustments or repairs.

### 4.3 Hoist Controls

- 4.3.1 For hoists mounted to motorized trolleys follow the control instruction included in the trolley's Owner's Manual.
- 4.3.2 Pendant Control - When using the pendant control depress the up lever to raise the hoist or the down lever to lower the hoist as shown in Figure 4-1 below. To stop motion release the lever switches.

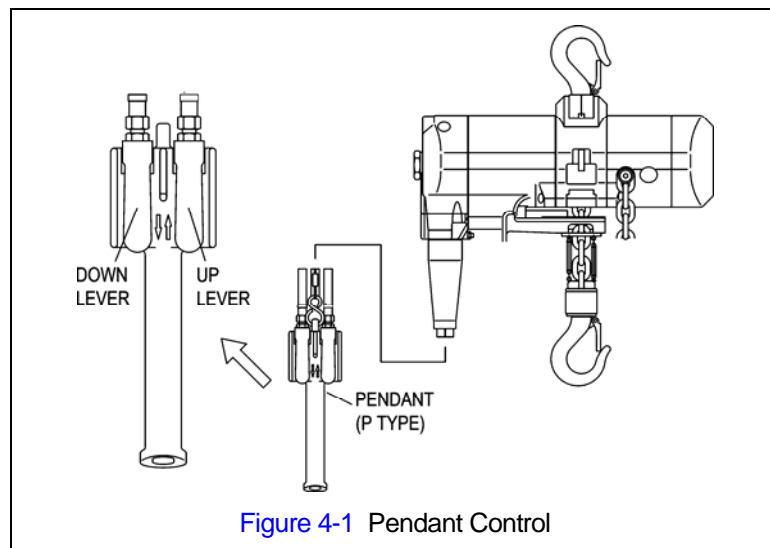

- 4.3.3 Cord Control - When using a hoist with cord control, pull down on the appropriate colored cord to raise or lower the hoist. White indicates the raise control and red indicates lowering control. Release the cords to stop the hoist. Refer to [Figure 4-2](#) below.

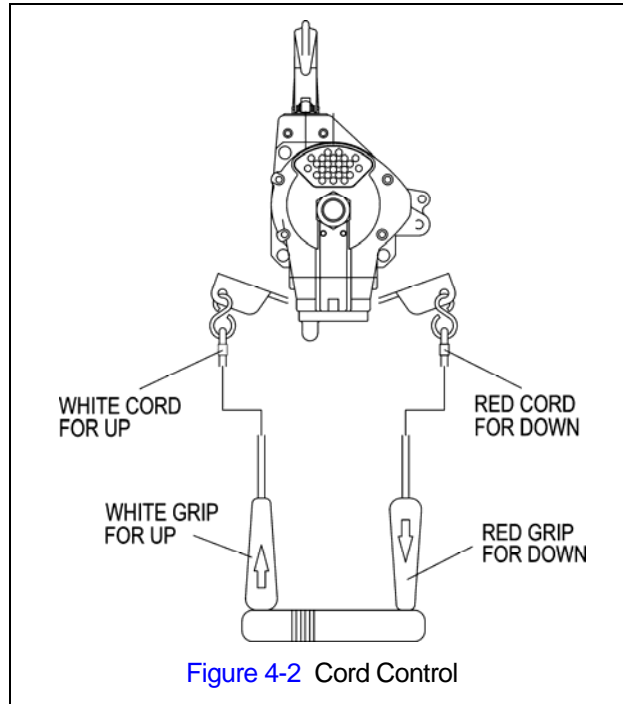

- 4.3.4 **CAUTION** Make sure the motor completely stops before reversing direction.

## 4.4 Adjusting the Controls

- 4.4.1 For pendant control, the speed can be adjusted by the amount the lever is depressed. As shown below in [Figure 4-3](#), by depressing the lever slightly, you will be able to control the hoist's motions slowly and with more precision. By depressing the lever further, the speed of the hoist will be increased until the lever is fully depressed. Refer to [Figure 4-3](#).
- 4.4.2 For the cord type control, adjust the speed by varying the amount of pull on the cord. Refer to [Figure 4-4](#).

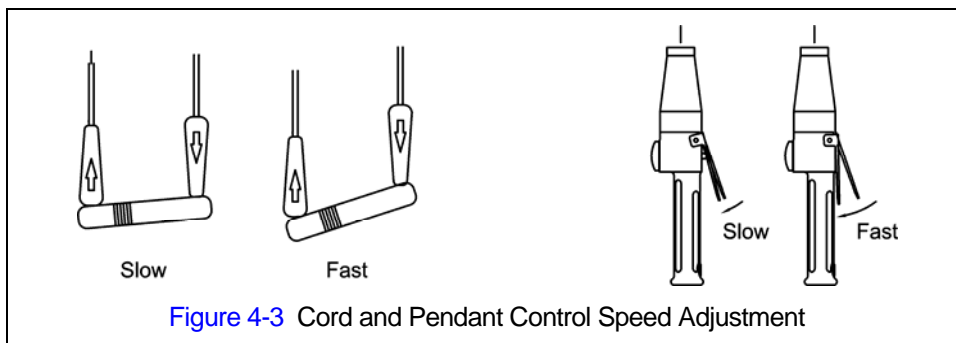

## 4.5 Speed Adjustment Controls

- 4.5.1 The hoist is equipped with speed adjustment controls. The controls allow the hoist lifting and lowering speeds to be reduced for those applications requiring slower speeds or better speed control. The speed adjustment controls are set for the highest speed from the factory. The speed adjustment controls are located on top of the valve section of the hoist as shown in [Figure 4-4](#).
- 4.5.2 **CAUTION** The hoist must be stopped when adjusting the lifting and lowering speeds.
- 4.5.3 To reduce the lifting/lowering speeds remove the speed adjustment covers to gain access to the speed adjustment screws as shown in [Figure 4-4](#). The covers may be plastic or aluminum. Viewed from the valve side of the hoist, the lowering adjustment screw is on the left and the lifting adjustment screw is on the right. The lifting and lowering adjustment mechanisms are not connected, allowing separate adjustments for lifting and lowering speeds.
- 4.5.4 Referring to [Figure 4-4](#) the hoist is at the highest speed when the screw is in the “vertical” position and at the lowest speed when in the “horizontal” position. Speed adjustment can be made between these positions.

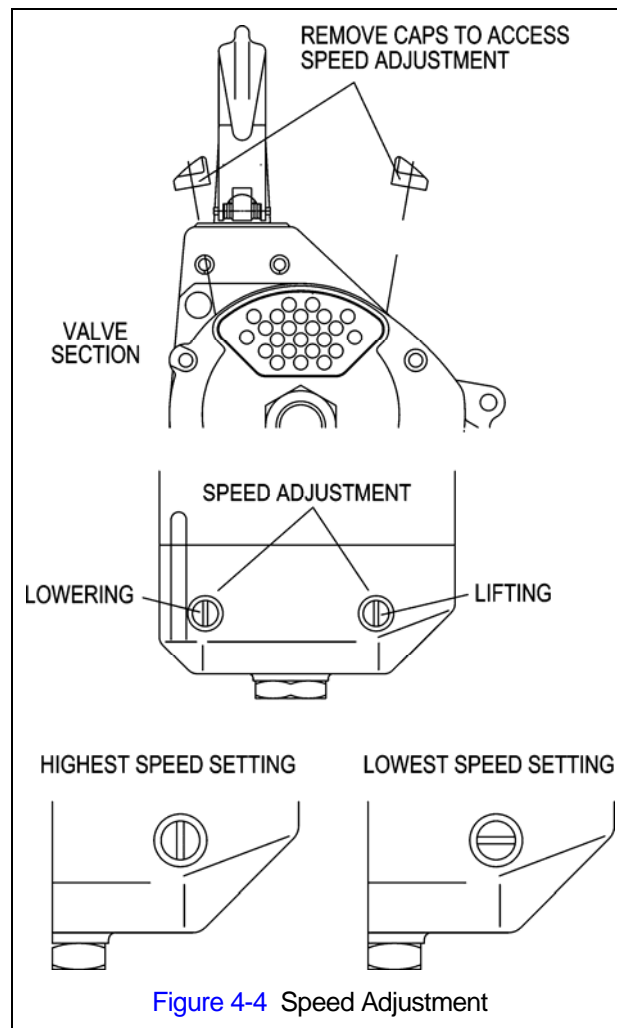

[Figure 4-4](#) Speed Adjustment

## 4.6 Pendant Controllability Adjustment

- 4.6.1 The standard pendant hose length is 8.1 feet. For longer pendant hose lengths the speed controllability from the pendant may be diminished. The reduction in speed control is a result of pressure loss due to the longer pendant hose. The pendant hose extension adjustment control provides a screw adjustment method to reduce the air pressure loss to provide normal pendant/hoist operation. The adjustment screw is set fully open from the factory for normal operation and to allow the fine feathering feature.
- 4.6.2 To adjust the pendant air pressure locate the hex nut and hex screw as shown in Figure 4-5. The adjustment screw on the left is for adjusting the lowering speed and the adjustment screw on the right is for adjusting the lifting speed.
- 4.6.3 Adjustment is accomplished by loosening the hex nut with a 2.5mm wrench and turning the hex head screw clockwise. Once correct operation is obtained securely tighten the hex nut.
- 4.6.4 **⚠ CAUTION** If the adjustment screw is tightened too tight the fine feathering feature will be reduced or lost.

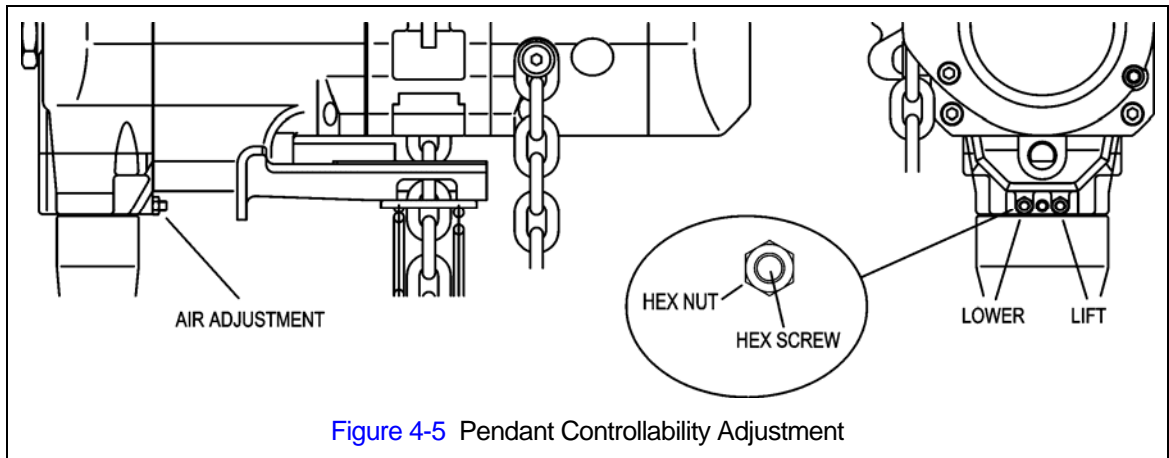

## 5.0 Inspection

### 5.1 General

- 5.1.1 The inspection procedure herein is based on ANSI/ASME B30.16. The following definitions are from ANSI/ASME B30.16 and pertain to the inspection procedure below.
- **Designated Person** - a person selected or assigned as being competent to perform the specific duties to which he/she is assigned.
  - **Qualified Person** - a person who, by possession of a recognized degree or certificate of professional standing, or who, by extensive knowledge, training, and experience, has successfully demonstrated the ability to solve or resolve problems relating to the subject matter and work.
  - **Normal Service** - that distributed service which involves operation with randomly distributed loads within the rated load limit, or uniform loads less than 65% of rated load for not more than 25% of the time.
  - **Heavy Service** - that service which involves operation within the rated load limit which exceeds normal service.
  - **Severe Service** - that service which involves normal or heavy service with abnormal operating conditions.

### 5.2 Inspection Classification

- 5.2.1 Initial Inspection - prior to initial use, all new, altered, or modified hoists shall be inspected by a designated person to ensure compliance with the applicable provisions of this manual.
- 5.2.2 Inspection Classification - the inspection procedure for hoists in regular service is divided into two general classifications based upon the intervals at which inspection should be performed. The intervals in turn are dependent upon the nature of the critical components of the hoist and the degree of their exposure to wear, deterioration, or malfunction. The two general classifications are herein designated as FREQUENT and PERIODIC, with respective intervals between inspections as defined below.
- 5.2.3 FREQUENT Inspection - visual examinations by the operator or other designated personnel with intervals per the following criteria:
- Normal service - monthly
  - Heavy service - weekly to monthly
  - Severe service - daily to weekly
  - Special or infrequent service - as recommended by a qualified person before and after each occurrence.
- 5.2.4 PERIODIC Inspection - visual inspection by a designated person with intervals per the following criteria:
- Normal service - yearly
  - Heavy service - semiannually
  - Severe service - quarterly
  - Special or infrequent service - as recommended by a qualified person before the first such occurrence and as directed by the qualified person for any subsequent occurrences.

### 5.3 Frequent Inspection

- 5.3.1 Inspections should be made on a FREQUENT basis in accordance with [Table 5-1](#), “Frequent Inspection.” Included in these FREQUENT Inspections are observations made during operation for any defects or damage that might appear between Periodic Inspections. Evaluation and resolution of the results of FREQUENT Inspections shall be made by a designated person such that the hoist is maintained in safe working condition.

<b>Table 5-1 Frequent Inspection</b>
All functional operating mechanisms for maladjustment and unusual sounds.
Operation of limit switch and associated components
Hoist braking system for proper operation
Hooks in accordance with ANSI/ASME B30.10
Hook latch operation
Load chain in accordance with <a href="#">Section 5.7</a>
Load chain reeving for compliance with <a href="#">Section 3.12</a> and <a href="#">7.3</a>
Air valves and components for leakage or damage

### 5.4 Periodic Inspection

- 5.4.1 Inspections should be made on a PERIODIC basis in accordance with [Table 5-2](#), “Periodic Inspection.” Evaluation and resolution of the results of PERIODIC Inspections shall be made by a designated person such that the hoist is maintained in safe working condition.
- 5.4.2 For inspections where load suspension parts of the hoist are disassembled, a load test per ANSI/ASME B30.16 must be performed on the hoist after it is re-assembled and prior to its return to service.

<b>Table 5-2 Periodic Inspection</b>
Requirements of frequent inspection.
Evidence of loose bolts, nuts, or rivets.
Evidence of worn, corroded, cracked, or distorted parts such as load blocks, suspension housing, chain attachments, clevises, yokes, suspension bolts, shafts, gears, bearings and pins.
Evidence of damage to hook retaining nuts or collars and pins, and welds or rivets used to secure the retaining members.
Evidence of damage or excessive wear of load and idler sheaves.
Evidence of excessive wear on motor vanes or on load brake.
Evidence of damage of supporting structure or trolley, if used.
Function labels on pendant control stations for legibility.
Warning label properly attached to the hoist and legible (see <a href="#">Section 1.2</a> ).
End connections of load chain.

## 5.5 Occasionally Used Hoists

5.5.1 Hoists that are used infrequently shall be inspected as follows prior to placing in service:

- Hoist Idle More Than 1 Month, Less Than 1 Year: Inspect per FREQUENT Inspection criteria of [Section 5.3](#) above.
- Hoist Idle More Than 1 Year: Inspect per PERIODIC Inspection criteria of [Section 5.4](#) above.

## 5.6 Inspection Records

5.6.1 Dated inspection reports and records should be maintained at time intervals corresponding to those that apply for the hoist's PERIODIC interval per [Section 5.2.4](#). These records should be stored where they are available to personnel involved with the inspection, maintenance, or operation of the hoist.

5.6.2 A long range chain inspection program should be established and should include records of examination of chains removed from service so a relationship can be established between visual observation and actual condition of the chain.

## 5.7 Inspection Methods and Criteria

5.7.1 This section covers the inspection of specific items. The list of items in this section is based on those listed in ANSI/ASME B30.16 for the Frequent and Periodic Inspection. In accordance with ANSI/ASME B30.16, these inspections are not intended to involve disassembly of the hoist. Rather, disassembly for further inspection would be required if frequent or periodic inspection results so indicate. Such disassembly and further inspection should only be performed by a qualified person trained in the disassembly and re-assembly of the hoist.

<b>Table 5-3 Hoist Inspection Methods and Criteria</b>			
<b>Item</b>	<b>Method</b>	<b>Criteria</b>	<b>Action</b>
Functional operating mechanisms.	Visual, Auditory	Mechanisms should be properly adjusted and should not produce unusual sounds when operated.	Repair or replace as required.
Limit Lever	Function	Proper operation. Actuation of limit lever should stop hoist.	Repair or replace as required.
Chain Lever/Limit Lever Assembly	Visual, Function	Lever should not be bent or significantly worn and should be able to move freely.	Replace.
Braking System	Function	Braking distance should not exceed approximately five chain links.	Repair or replace as required.
Hooks - Surface Condition	Visual	Should be free of significant rust, weld splatter, deep nicks, or gouges.	Replace.
Hooks - Fretting wear	Measure	The "u" dimension should not be less than minimum value listed in <a href="#">Table 5-6</a> .	Replace.
Hooks - Stretch	Measure	The "K" dimension should not exceed the maximum value for replacement from <a href="#">Table 5-6</a> (See <a href="#">Section 3.12</a> ).	Replace.

**Table 5-3 Hoist Inspection Methods and Criteria (continued)**

Item	Method	Criteria	Action
Hooks - Bent Shank or Neck	Visual	Shank and neck portions of hook should be free of deformations	Replace.
Hooks - Yoke Assembly	Visual	Should be free of significant rust, weld splatter, nicks, gouges. Holes should not be elongated, fasteners should not be loose, and there should be no gap between mating parts.	Clean/Lubricate, or replace as required.
Hooks - Swivel Bearing	Visual, Function	Bearing parts and surfaces should not show significant wear, and should be free of dirt, grime and deformations. Hook should rotate freely with no roughness.	Clean/lubricate, or replace as required.
Hooks - Idle Sheave and Axle (Bottom Hook on Double Fall Hoist)	Visual, Function	Pockets of Idle Sheave should be free of significant wear. Idle Sheave surfaces should be free of nicks, gouges, dirt and grime. Bearing parts and surfaces of Idle Sheave and Axle should not show significant wear. Idle Sheave should rotate freely with no roughness or significant free play.	Clean/lubricate, or replace as required.
Hooks - Hook Latches	Visual, Function	Latch should not be deformed. Attachment of latch to hook should not be loose. Latch spring should not be missing and should not be weak. Latch movement should not be stiff - when depressed and released latch should snap smartly to its closed position.	Replace.
Load Chain - Surface Condition	Visual	Should be free of rust, nicks, gouges, dents, and weld splatter. Links should not be deformed, and should not show signs of abrasion. Surfaces where links bear on one another should be free of significant wear.	Replace.
Load Chain - Pitch and Wire Diameter	Measure	The "P" dimension should not be greater than discard value listed in <a href="#">Table 5-7</a> . The "d" dimension should not be less than discard value listed in <a href="#">Table 5-7</a> .	Replace. Inspect Load Sheave (and Idle Sheave for multiple fall hoists).
Load Chain - Lubrication	Visual, Auditory	Entire surface of each chain link should be coated with lubricant and should be free of dirt and grime. Chain should not emit cracking noise when hoisting a load.	Clean/lubricate (see <a href="#">Sections 6.0</a> ).
Load Chain - Reeving	Visual	Chain should be reeved properly through Load Sheave (and Idle Sheave for double fall hoist) - refer to <a href="#">Section 3.12</a> . Chain should be installed properly - refer to <a href="#">Section 7.2</a> .	Reeve/Install chain properly.
Chain Spring -	Visual	Chain springs should not be deformed or compressed.	Replace
Bolts, Nuts and Rivets	Visual, Check with Proper Tool	Bolts, nuts and rivets should not be loose.	Tighten or replace as required.

**Table 5-3 Hoist Inspection Methods and Criteria (continued)**

Item	Method	Criteria	Action
Housing and Mechanical Components	Visual, Auditory, Vibration, Function	Hoist components including load blocks, suspension housing, chain attachments, clevises, yokes, suspension bolts, shafts, gears, bearings, pins and rollers should be free of cracks, distortion, significant wear and corrosion. Evidence of same can be detected visually or via detection of unusual sounds or vibration during operation.	Replace
Chain Separator	Visual, Measure	The Chain Separator should be free of cracks, distortion and significant wear and corrosion. The "L" and "W" dimension should not be greater than maximum value listed in <a href="#">Table 5-5</a> .	Replace
Motor Brake	Measure, Visual	Motor brake dimension should be within the allowable limits of <a href="#">Table 5-4</a> . See <a href="#">Section 7.1</a> for gaining access to motor brake. Braking surfaces should be clean, free of grease/oil and should not be glazed.	Replace
Load Sheave	Visual	Pockets of Load Sheave should be free of significant wear. See <a href="#">Section 7.4</a> to gain visual access to the load sheave.	Replace.
Pendant Control Levers	Visual, Function	Depressing and releasing pendant control levers should cause hoist to operate.	Repair or replace as necessary.
Pendant - Housing	Visual	Pendant housing should be free of cracks and mating surfaces of parts should seal without gaps.	Replace.
Pendant - Tubing	Visual, auditory	Tubing to pendant control switches should not be loose or be leaking air.	Repair or replace as necessary.
Pendant - Labels	Visual	Labels denoting functions should be legible.	Replace.
Warning Labels	Visual	Warning Labels should be affixed to the hoist (see <a href="#">Section 1.2</a> ) and they should be legible.	Replace
Hoist Capacity Label	Visual	The label that indicates the capacity of the hoist should be legible and securely attached to the hoist.	Replace.

**Table 5-4 Brake Disc Dimension**

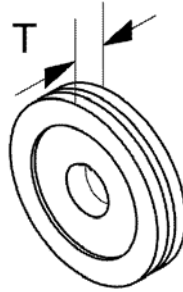

Hoists	Parts View Figure No.	Std Dimension Inch (mm)	Minimum Value for Replacement Inch (mm)
TCS250C2/P2 TCS500C2/P2 TCS1000C2/P2	152	T = 0.31 (8)	T = 0.29 (7.3)

**Table 5-5 Chain Separator Dimensions**

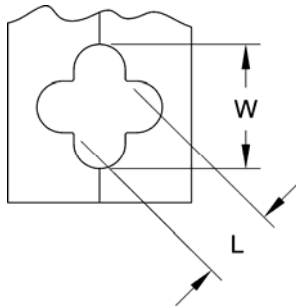

Hoists	Parts View Figure No.	Std Dimension Inch (mm)	Maximum Value for Replacement Inch (mm)
TCS250C2/P2 TCS500C2/P2 TCS1000C2/P2	104	L = 0.51 (13) W = 0.95 (24)	L = 0.63 (16) W = 1.04 (26.5)

**Table 5-6 Top Hook & Bottom Hook Dimensions**

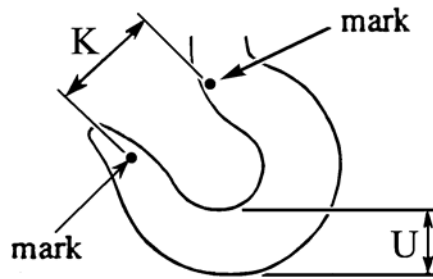

Dimensions K and U should be measured and recorded below prior to any use when the hook is first placed into service.

Hoists	Parts View Figure No.	Recorded Dimension When New	Maximum/Minimum Value for Replacement
TCS250C2/P2	2-1	Top Hook K = _____ Top Hook U = _____	For K if the measured dimension exceeds 1.05 times the recorded new dimension, the hook should be replaced.  For U if the measured dimension is less than .9 times the recorded new dimension, the hook should be replaced.
	2-1	Bottom Hook K = _____ Bottom Hook U = _____	
TCS500C2/P2	2-1	Top Hook K = _____ Top Hook U = _____	
	2-1	Bottom Hook K = _____ Bottom Hook U = _____	
TCS1000C2/P2	2-2	Top Hook K = _____ Top Hook U = _____	
	2-2	Bottom Hook K = _____ Bottom Hook U = _____	

**Table 5-7 Chain Dimensions**

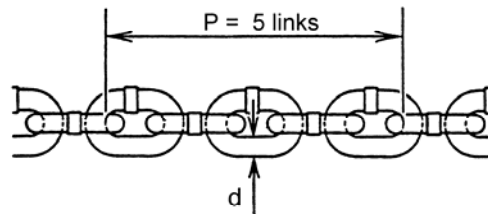

Product Code	Parts View Figure No.	"P" Dimension inch (mm)		"d" Dimension inch (mm)	
		Standard	Discard	Standard	Discard
TCS250C2/P2 TCS500C2/P2 TCS1000C2/P2	114	3.76 (95.5)	3.82 (96.9)	0.25 (6.3)	0.22 (5.7)

## 6.0 Lubrication

### 6.1 Air Hoist Lubrication

6.1.1 See [Section 3.0](#) for lubrication requirements.

6.1.2 **⚠ CAUTION** Lubrication to the motor will be provided primarily by the air supply lubricator. The recommended amount is 10-15 drops/minute (2-3cc/min.). Refer to [Table 6-1](#) below for the approved lubricant for use with your air hoist.

6.1.3 Additional lubrication to the reduction gears is not necessary. When disassembling the hoist for service or repair, apply new grease to the gears before reassembling the hoist.

### 6.2 Load Chain Lubrication

6.2.1 For longer life, the load chain should be lubricated.

6.2.2 The load chain lubrication should be accomplished after cleaning the load chain with an acid free cleaning solution.

6.2.3 Apply Harrington lubricating grease (Part No. ER1BS1951) or an equivalent to industrial general lithium grease, NLGI No. 0, to the bearing surfaces of the load chain links as indicated by the shaded areas in [Figure 6-2](#). Also apply the grease to the areas of the load chain (shaded areas in [Figure 6-2](#)) that contact the load sheave. Insure that the grease is applied to the contact areas in the load sheave pockets.

6.2.4 Machine or gear oil (grade ISO VG 46 or 68 oil or equivalent) may be used as an alternative lubricant but must be applied more frequently.

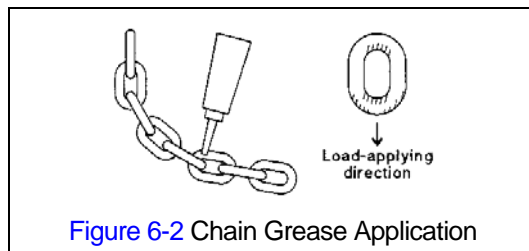

[Figure 6-2](#) Chain Grease Application

6.2.5 The chain should be lubricated every 3 months (more frequently for heavier usage or severe conditions).

6.2.6 For dusty environments, it is acceptable to substitute a dry lubricant.

### 6.3 Hooks and Suspension Components

- 6.3.1 Hooks - Bearings should be cleaned and lubricated at least once per year for normal usage. Clean and lubricate more frequently for heavier usage or severe conditions.
- 6.3.2 Suspension Pins - Lubricate at least twice per year for normal usage; more frequently for heavier usage or severe conditions.

<b>Table 6-1 Table of Approved Lubricants</b>			
<b>Application</b>	<b>Part Location</b>	<b>Lubrication</b>	<b>Grade</b>
Air motor	Lubricator	Turbine Oil	ISO VG 32-56 or equivalent
Load chain & pocket wheel	Load chain	Grease, Machine or gear oil	- HHI Chain Grease P/N ER1BS1551 - NLGI No. 0 - ISO VG 46-68 or equivalent
Hook bearings & suspension pins	Top & bottom hook sets	Grease	National Lubricating Grease #3
Gears and Bearings	Gear Section	Grease	National Lubricating Grease #2

## 7.0 Maintenance and Handling

### 7.1 Brake

- 7.1.1 The hoist brake is not adjustable.
- 7.1.2 Inspect the brake disc in accordance with [Section 5.7, Table 5-4](#).
- 7.1.3 The following is the hoist brake inspection procedure. Refer to [Figure 7-1](#).

- 1) **⚠️ WARNING** HAZARDOUS AIR PRESSURE IS PRESENT IN THE HOIST, IN THE SUPPLY OF COMPRESSED AIR TO THE HOIST, AND IN THE CONNECTIONS BETWEEN COMPONENTS. Shut off the air supply and stop the airflow completely. Lock out and tag out in accordance with ANSI Z244.1 "Personnel Protection -Lockout/Tagout of Energy Sources".
- 2) Gradually and evenly back out 4 Hex Socket Cap Screws (A) from Brake Cover (B) from Gear Case (J) to slowly decrease spring tension (C) of Brake Piston (D) against Brake Disc (E).
- 3) Remove Brake Cover (B), Brake Piston (D), Springs (C), and O-Rings from Gear Case (J). Set parts aside for reassembly.
- 4) Remove Brake Disc for inspection and measurement. Refer to "Motor Brake" in [Table 5-3, "Hoist Inspection Methods and Criteria"](#).
- 5) Prior to reassembly, clean all surfaces of debris, dirt and loose paint. Apply a light film of grease to all O-Ring seals.
- 6) Reassemble in reverse order. Torque all mounting hardware evenly during the reassembly process.

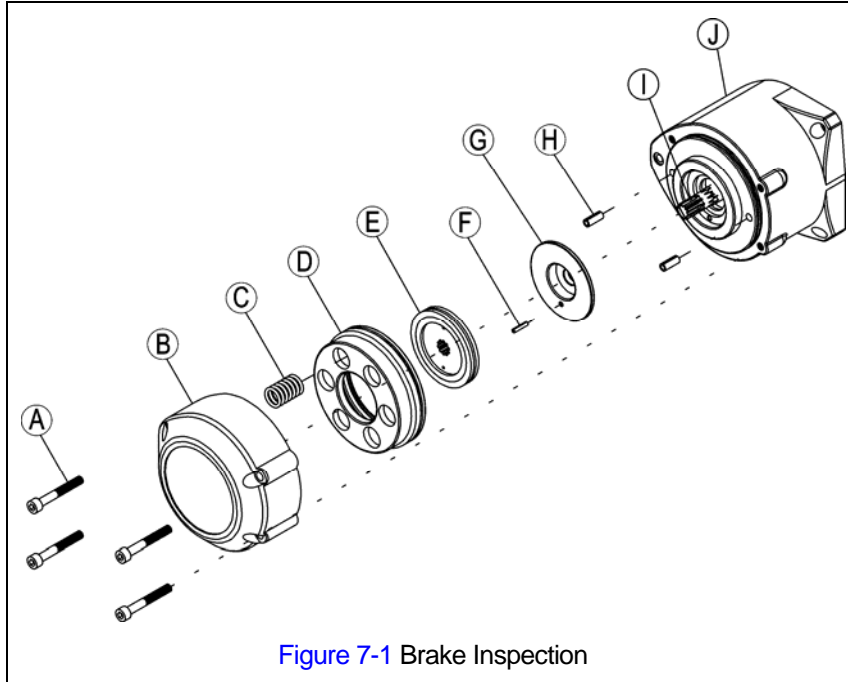

## 7.2 Load Chain

7.2.1 Lubrication and Cleaning – Refer to [Section 6.2](#).

7.2.2 Replacement

- 1) **⚠ CAUTION** An air supply line must be connected to the hoist in order to perform the following procedures.
- 7) **⚠ WARNING** Be certain that the replacement chain is obtained from Harrington and is the exact size, grade and construction as the original chain. The new load chain must have an even number of links so that the end links are oriented 90° from each other.
- 8) Remove the Bottom Hook Complete Set and Button Head Screw connecting the no-load end of the chain to the hoist body. Keep the Bottom Hook Complete Set and Button Head Screw for reuse on new chain. Carefully operate the hoist in the down direction to remove old chain.
- 9) **⚠ CAUTION** When replacing load chain, check for wear on mating parts, i.e. Load Sheave, Chain Guides, Bottom Hook Complete Set and replace parts if necessary. If the load chain is being replaced due to damage or wear out, destroy the old chain to prevent its reuse.
- 10) **⚠ CAUTION** Invert the hoist such that the chain separator openings are facing up and tilt the hoist approximately 30° as shown in [Figure 7-2](#). Insert the chain into the chain separator on the no-load side opening making certain that the first link is a standing link and that its weld is facing away from the centerline of the hoist.
- 11) **⚠ CAUTION** Operate the hoist as slowly as possible in the down direction to catch the Load Chain and pull it through the hoist. Make sure the chain feeds smoothly while operating the hoist. If binding occurs, stop and reverse the hoist direction to the back the chain out. Reinsert the chain again while gradually operating hoist controls. Continue until a sufficient quantity of Chain is fed through the hoist to attach the Bottom Hook Complete Set.
- 12) Ensure that of the Chain remains free of twists and attach the no-load end of the chain to the hoist body with the Flat Washer and Button Head Screw. Reinstall the Bottom Hook Complete Set. Torque the Button Head Screw to 78 lbf-in. Refer to [Figure 7-3](#) and [Figure 7-4](#).
- 13) After installation has been completed, perform steps outlined in [Section 3.14](#) "Pre-operational Checks and Trial Operation".

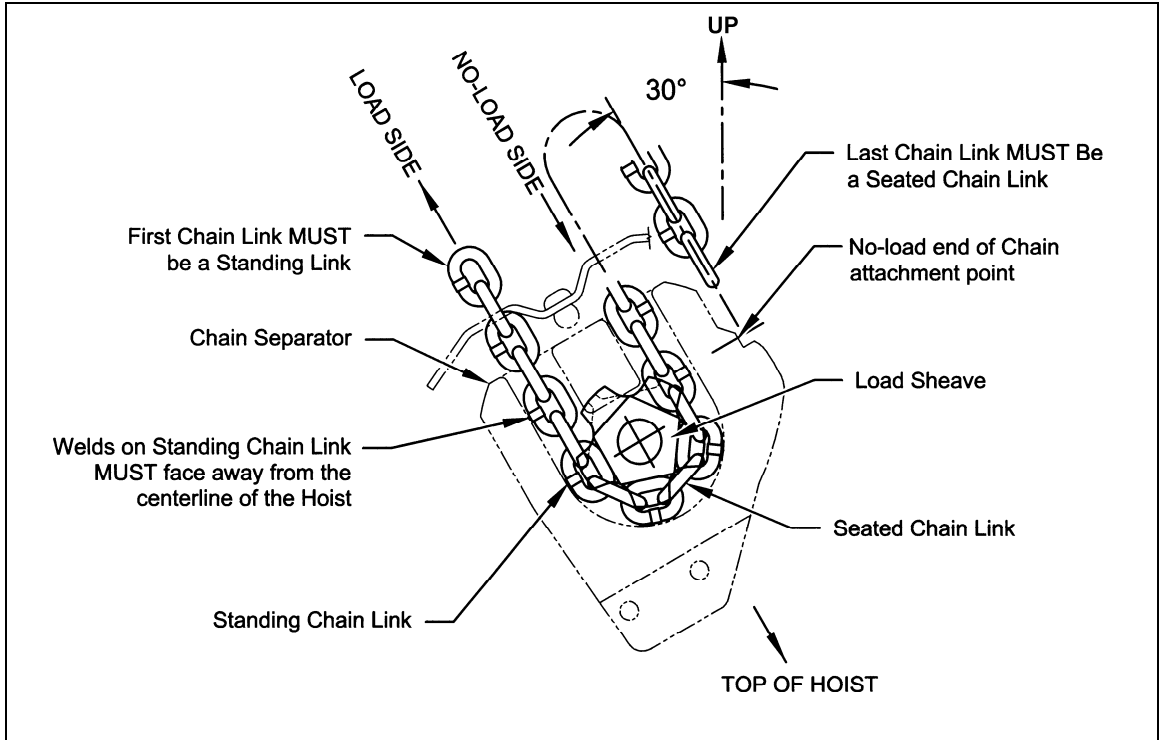

Figure 7-2 Load Chain Installation Diagram

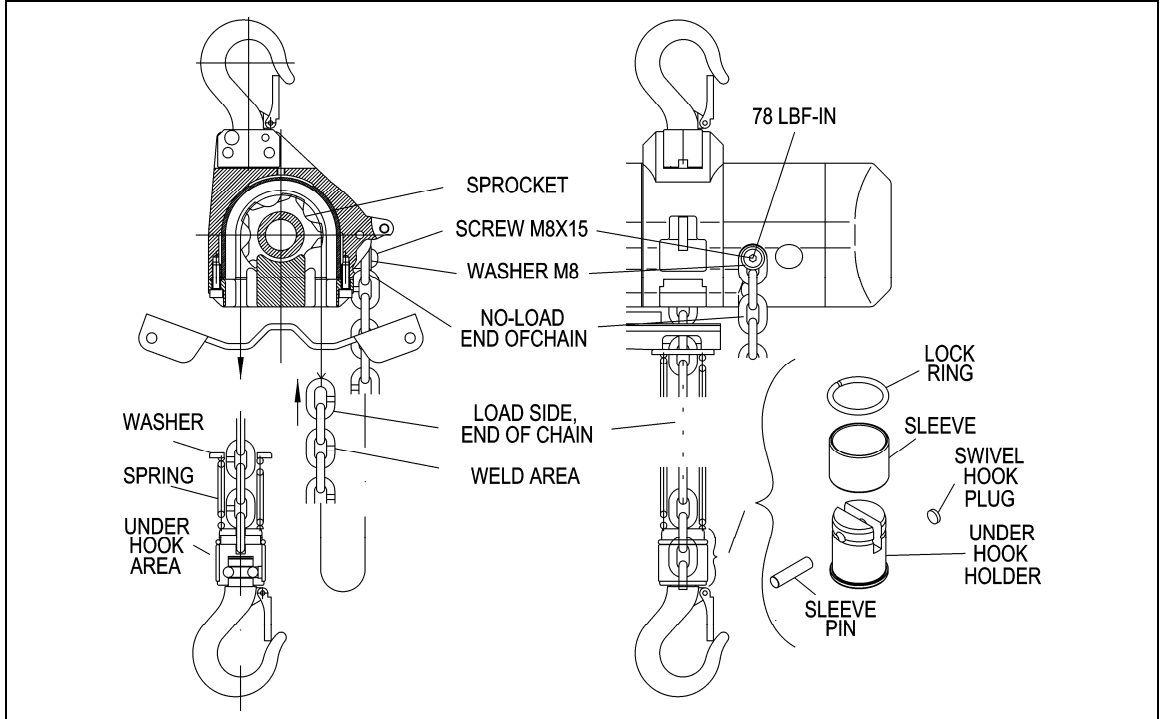

Figure 7-3 Single Fall Chain Connections

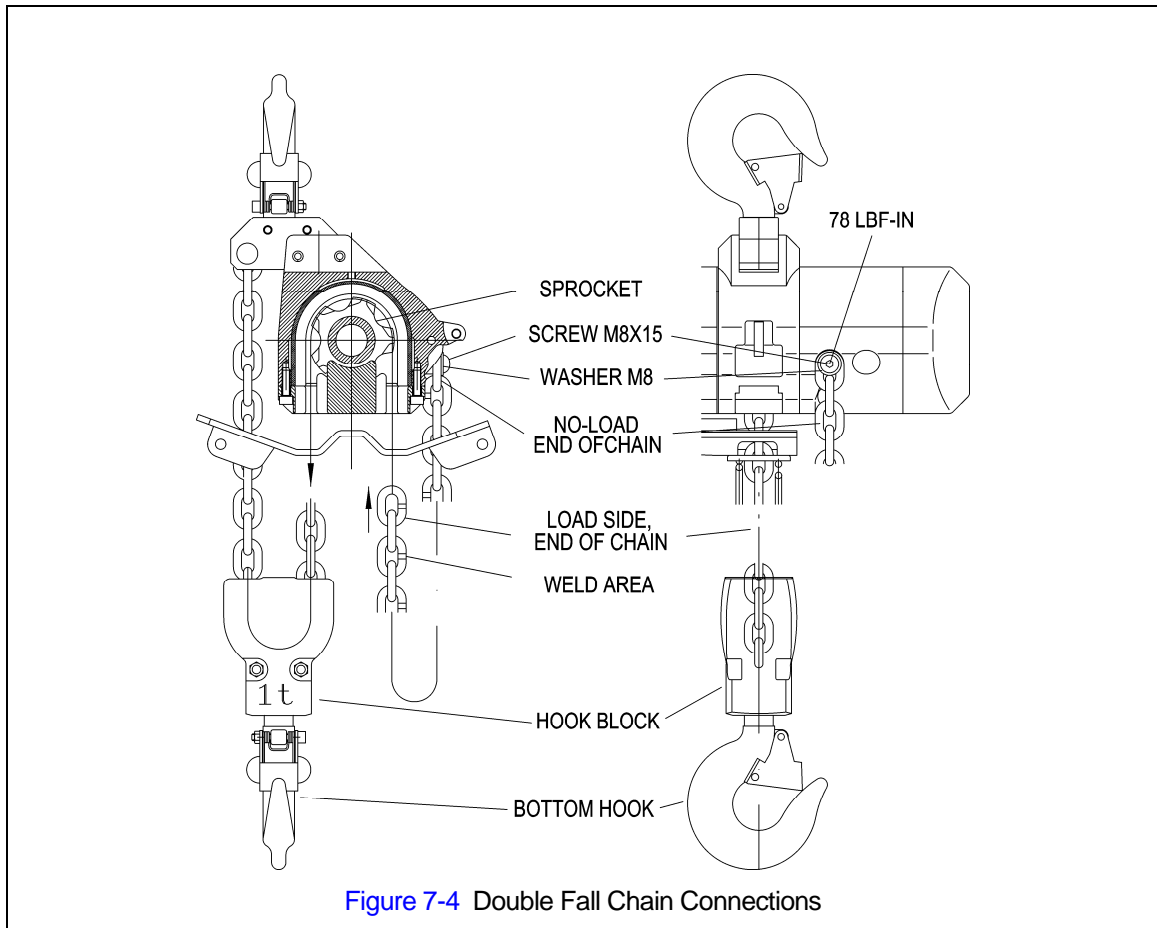

Figure 7-4 Double Fall Chain Connections

### 7.3 Pendant

7.3.1 The following procedure covers the installation of the Pendant Hose (Parts List Figure Number 360) and the Pendant Valve. Refer to [Figure 7-5](#).

- 1) Place boot on the ends of the Pendant Hoses to be attached to the Manifold Block on the hoist.
- 2) Attach pendant hose to hoist body using the one-piece fittings and screw type clamps (hose bands).
- 3) Attach pendant hoses to the pendant valve using the 2 piece fittings and crimp type hose clamps (hose bands). Refer to [Figure 7-5](#) for the correct placement of the Hoses.
- 4) Attach the Strain Relief wire S-Hook on the Pendant Valve and Manifold Block using the S-Hook.
- 5) Slide the Boot in to place over the Hose Fittings at the Manifold Block on the hoist.
- 6) **⚠ CAUTION** Operate hoist and make sure the direction of hook travel agrees with the control levers on the Pendant Valve.

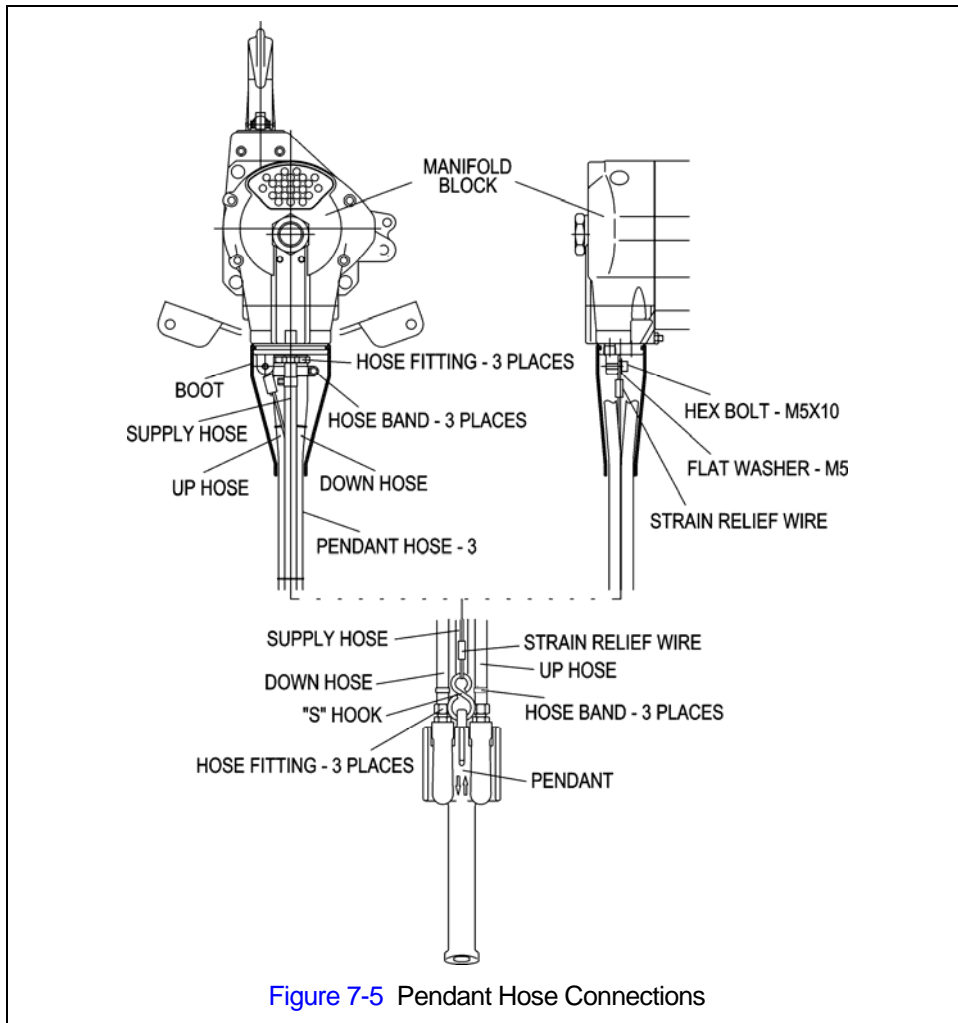
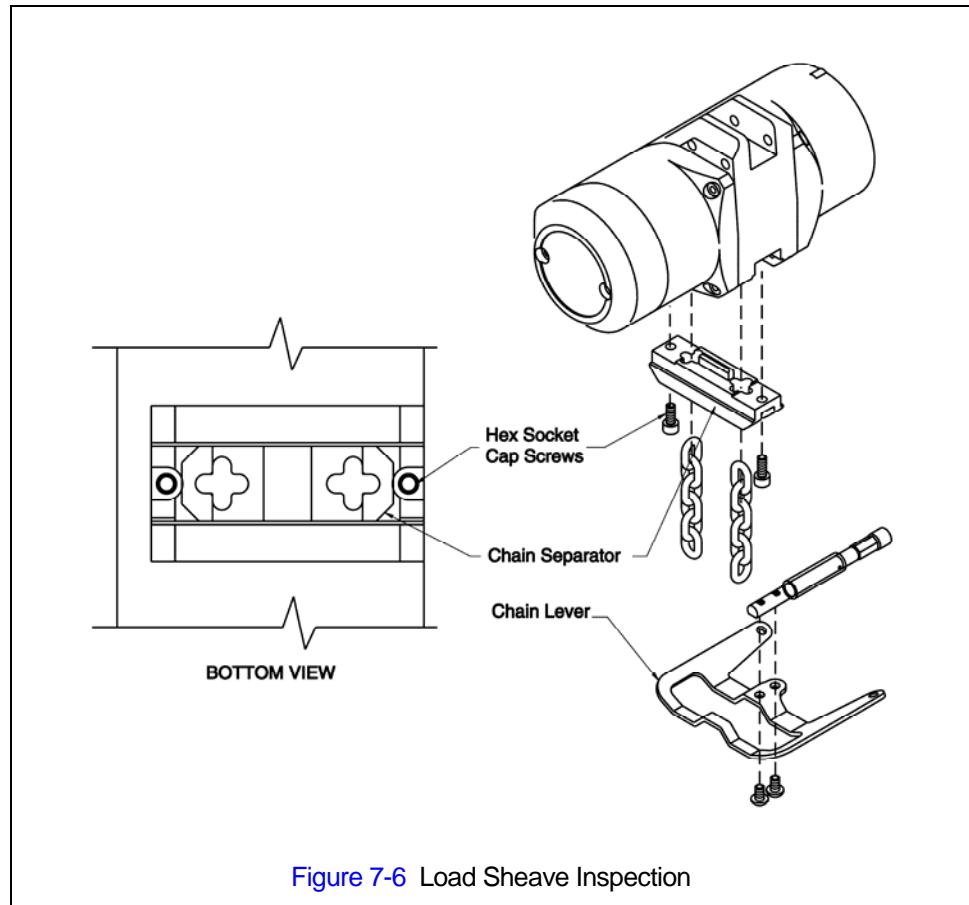

Figure 7-5 Pendant Hose Connections

## 7.4 Load Sheave Inspection

7.4.1 Perform this inspection by removing the chain separator and viewing the load sheave while operating the hoist slowly, with no load, and in accordance with [Section 4](#) "Operation". Refer to [Figure 7-6](#) and remove the chain separator as follows:

- 1) **CAUTION** An air supply line must be connected to the hoist in order to perform the following procedures.
- 2) Remove 2 Socket Bolts attaching the Chain Separator to the Wheel Housing and drop the Chain Separator down.
- 3) Inspect the Load Sheave. Refer to "Load Sheave" in [Table 5-3](#), "Hoist Inspection Methods and Criteria".
- 4) Reverse the procedure to reassemble the hoist.



## 7.5 Storage

7.5.1 Whenever the hoist is to be placed into storage, place extra lubricating oil into the air inlet opening and circulate the air motor before plugging the inlet. Make certain that no debris, dirt or moisture is allowed to enter the air hoist through air inlet opening during preparations for storage.

7.5.2 The storage location should be clean and dry.

## 7.6 Outdoor Installation

7.6.1 For hoist installations that are outdoors, the hoist should be covered when not in use.

7.6.2 In order to prevent internal corrosion from occurring, the hoist must be operated using proper quality air at least once per week by raising and lowering the hoist one full cycle. Note: the possibility of corrosion in the valve section of the hoist increases for areas where salt air and high humidity are present. For such situations you may need to operate your hoist more often than once per week.

## 8.0 Troubleshooting

### **WARNING**

**HAZARDOUS AIR PRESSURE IS PRESENT IN THE HOIST, IN THE SUPPLY OF COMPRESSED AIR TO THE HOIST, AND IN CONNECTIONS BETWEEN COMPONENTS.**

Before performing ANY maintenance on the equipment, de-energize the supply of compressed air to the equipment, and lock and tag the supply device in the de-energized position. Refer to ANSI Z244.1, "Personnel Protection - Lockout/Tagout of Energy Sources."

Only Trained and competent personnel should inspect and repair this equipment.

**Table 8-1 Troubleshooting Guide**

Symptom	Cause	Remedy
Does not operate	Lack of air pressure or loss of air supply.	Repair or adjust air supply or filters.
	Seizure of Main Spool, Brake Spool, or Air Motor.	Repair at service facility.
	Seizure of brake or brake mechanism fails to release.	Repair at service facility.
	Bending or crimping of pendant control hose(s)	Correct or repair the bend or crimp in control hose(s)
	Hoist is overloaded.	Reduce the load to the rated capacity of hoist.
Lifting speed is slow	Low air pressure at hoist inlet port.	Repair or adjust air supply or filters. Check for air line obstruction.
	Air supply hose or piping is too small.	Replace hose or piping sizes with recommended sizes in <a href="#">Section 3.0</a> .
	Malfunction of brake.	Repair at service facility.
	Bending or crimping of pendant control hose(s)	Correct or repair the bend or crimp in control hose(s)
	Lack of sufficient oil in air supply to hoist	Increase oil in air supply to hoist in accordance with requirements in <a href="#">Section 3.0</a> .
	Exhaust Silencer clogged	Clean or replace.
	Air flow capacity of compressed air system insufficient	Increase air flow capacity of compressed air system to requirements in <a href="#">Section 2.0</a> .
	Air motor vanes or bearings worn	Repair at service facility.
	Air supply to hoist contains dirt or debris	Filter the air supply to the hoist in accordance with the requirements in <a href="#">Section 3.0</a> .
Unable to lift rated load	Lack of air pressure or loss of air supply.	Repair or adjust air supply or filters.

**Table 8-1 Troubleshooting Guide (continued)**

<b>Symptom</b>	<b>Cause</b>	<b>Remedy</b>
Hoist moving in wrong direction (pendant control)	Pendant control hoses are terminated to incorrect ports on hoist body.	Connect the control tubes in accordance with <a href="#">Section 7.3</a> .
Hoist lowers but will not lift	Hoist is overloaded.	Reduce load to hoist rated capacity.
	Faulty pendant control or control hose(s)	Repair or replace pendant control or control hose(s)
	Lack of air pressure or partial loss of or leakage in air supply.	Repair or adjust air supply or filters.
Hoist continues running after pendant or cord is released	Control Valves	Inject approx. 20 drops of oil into inlet port to lubricate the main spool. If spool still sticks, repair at service facility.
	Valve in Pendant Handle stuck	Repair at service facility
Hoist drifts excessively when hoist is stopped	Brake is not holding.	Repair brake at service facility.

## 9.0 Warranty

Warranty explanation and terms.

All products sold by Harrington Hoists, Inc. are warranted to be free from defects in material and workmanship from date of shipment by Harrington for the following periods:

**Manual Hoists & Trolleys - 2 years**

**Air and Electric Powered Hoists, Trolleys, and Crane Components - 1 year**

**Spare / Replacement Parts - 1 year**

The product must be used in accordance with manufacturer's recommendations and must not have been subject to abuse, lack of maintenance, misuse, negligence, or unauthorized repairs or alterations.

Should any defect in material or workmanship occur during the above time period in any product, as determined by Harrington Hoist's inspection of the product, Harrington Hoists, Inc. agrees, at its discretion, either to replace (not including installation) or repair the part or product free of charge and deliver said item F.O.B. Harrington Hoists, Inc. place of business to customer.

Customer must obtain a Return Goods Authorization as directed by Harrington or Harrington's published authorized repair center prior to shipping product for warranty evaluation. An explanation of the complaint must accompany the product. Product must be returned freight prepaid. Upon repair, the product will be covered for the remainder of the original warranty period. If it is determined there is no defect, or that the defect resulted from causes not within the scope of Harrington's warranty, the customer will be responsible for the costs of returning the product.

Harrington Hoists, Inc. disclaims any and all other warranties of any kind expressed or implied as to the product's merchantability or fitness for a particular application. Harrington will not be liable for death, injuries to persons or property or for incidental, contingent, special or consequential damages, loss or expense arising in connection with the use or inability whatever, regardless of whether damage, loss or expense results from any act or failure to act by Harrington, whether negligent or willful, or from any other reason.

## 10.0 Parts Information

A complete parts list is available from Harrington Hoists and is supplied separately with your hoist. The parts list is also available from Harrington's web site ([www.harringtonhoists.com](http://www.harringtonhoists.com)) or from any Harrington facility (see back cover of this manual).

When ordering Parts, please provide the Hoist code number located on the Hoist nameplate (see fig. below).

Reminder: Per [Sections 3.11.6](#) and [1.1](#) to aid in ordering Parts and Product Support, record the Hoist code number and serial number in the space provided on the cover of this manual.



Figure 10-1 TCS Nameplate

The parts list is arranged into the following sections:

Section	Page
10.1 Motor, Valve Body and Controls.....	46
10.2 Brake, Gears and Load Suspension Components.....	48
10.3 Chain Container Assembly.....	50



[www.harringtonhoists.com](http://www.harringtonhoists.com)

**Harrington Hoists, Inc.**

401 West End Avenue  
Manheim, PA 17545-1703  
Phone: 717-665-2000  
Toll Free: 800-233-3010  
Fax: 717-665-2861

**Harrington Hoists – Western Division**

2341 Pomona Rincon Rd. #103  
Corona, CA 92880-6973  
Phone: 951-279-7100  
Toll Free: 800-317-7111  
Fax: 951-279-7500

**TCSOM**