OWNER'S MANUAL

END TRUCKS Top Running & Underhung SERIES 3

1 Ton through 10 Ton Capacity

Model and Serial Number

WARNING

This equipment should not be installed, operated, or maintained by any person who has not read and understood all the contents of this manual. Failure to read and comply with the contents of this manual can result in serious bodily injury or death, and/or property damage.

HARRINGTON
HOISTS AND CRANES

INSTALLATION, OPERATION, MAINTENANCE AND PARTS MANUAL FOR SERIES 3 END TRUCKS

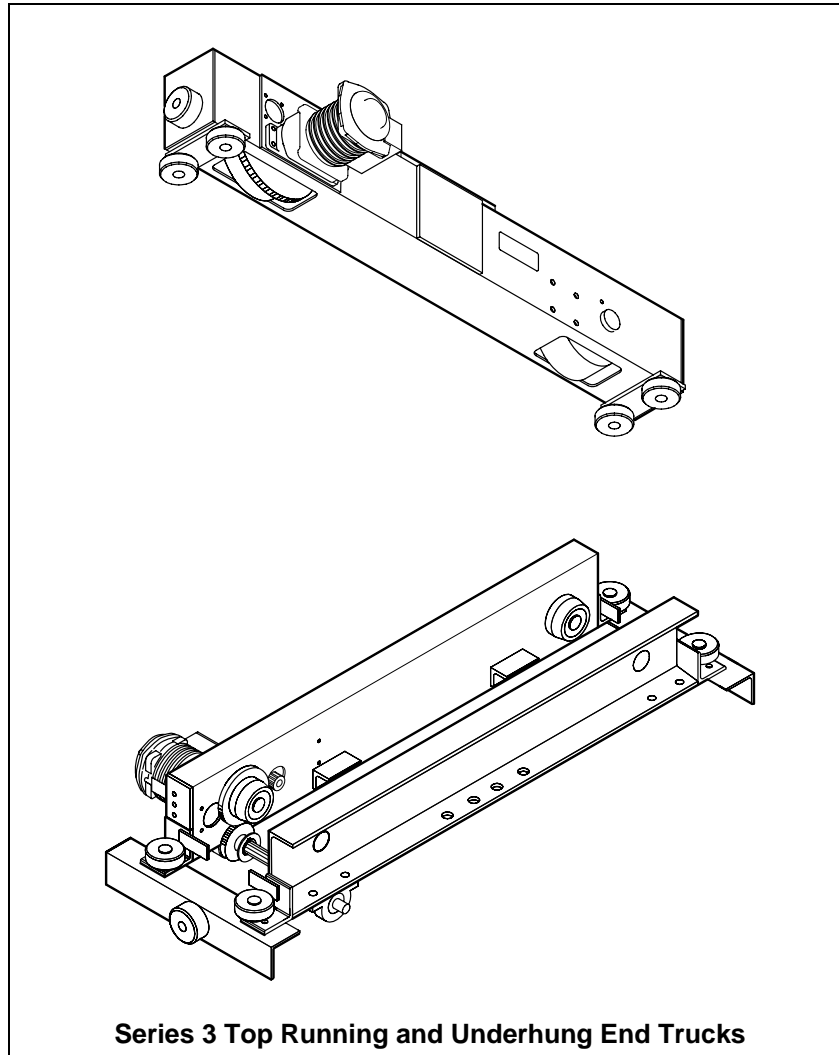

Series 3 Top Running and Underhung End Trucks

Thank you for selecting Harrington's Series 3 End Trucks for your material handling needs. We believe the Series 3 End Truck will provide you years of trouble-free service when properly maintained. Further, by applying the information in this manual, you will obtain dependable performance from our products.

The Harrington Series 3 End Truck was designed to operate either manually or with an electrical power source. Therefore, it is important that you follow this manual to properly install and operate your Series 3 End Trucks. It is the owner's and user's responsibility to determine the suitability of a product for a particular use. It is recommended that all applicable industry standards, and federal, state and local regulations be checked concerning the installation, operation and maintenance of the Series 3 End Trucks. Read all operating instructions and warnings before operation.

Table of Contents

Section	Page Number
1.0 Important Information and Warnings	6
1.1 Terms and Summary	
1.2 Warning Tags and Labels	
2.0 Technical Information	9
2.1 Specifications for Underhung End Trucks	
2.2 Specifications for Top Running End Trucks	
2.3 Component Names	
2.4 Bridge Crane Design Requirements	
3.0 Assembly, Installation and Test Trial Operation	25
3.1 Underhung End Trucks	
3.2 Top Running End Trucks	
3.3 Max-E-Lift End Trucks	
3.4 Drive Shafts for Geared End Trucks	
3.5 Crane Wiring	
3.6 Power Source	
3.7 Testing	
4.0 Operation	37
5.0 Inspection	38
5.1 General	
5.2 Inspection Classification	
5.3 Frequent Inspection	
5.4 Periodic Inspection	
5.5 Occasionally Used End Trucks	
5.6 Inspection Records	
5.7 Inspection Methods and Criteria	
6.0 Lubrication	44
7.0 Maintenance & Handling	45
7.1 General	
7.2 Gear Motor - Reduction Gear	
7.3 Gear Motor - Brake	
7.4 Brake Adjustment	
7.5 Storage	
7.6 Outdoor Installations	

Section	Page Number
8.0 Troubleshooting	49
9.0 Warranty	51
10.0 Parts List	52
10.1 Underhung End Trucks	
10.2 Top Running End Trucks	
10.3 Hand Wheel and Drive Shaft Assemblies	
10.4 Electric Gear Motors	
10.5 Gear Head Assembly	

1.0 Important Information and Warnings

1.1 Terms and Summary

This manual provides important information for personnel involved with the installation, operation and maintenance of this product. Although you may be familiar with this or similar equipment, it is strongly recommended that you read this manual before installing, operating, or maintaining the product.

Danger, Warning, Caution, and Notice

Throughout this manual, there are steps and procedures that can present hazardous situations. The following signal words are used to identify the degree or level of hazard seriousness.

▲ DANGER Danger indicates an imminently hazardous situation which, if not avoided, **will** result in **death or serious injury**, and property damage.

▲ WARNING Warning indicates an imminently hazardous situation which, if not avoided, **could** result in **death or serious injury**, and property damage.

▲ CAUTION Caution indicates a potentially hazardous situation which, if not avoided, **may** result **minor or moderate injury** or property damage.

NOTICE Notice is used to notify people of installation, operation, or maintenance information which is important but not directly hazard-related.

▲ CAUTION

These general instructions deal with the normal installation, operation, and maintenance situations encountered with the equipment described herein. The instructions should not be interpreted to anticipate every possible contingency or to anticipate the final system, crane, or configuration that uses this equipment. For systems using the equipment covered by this manual, the supplier and owner of the system are responsible for the system's compliance with all applicable industry standards, and with all applicable Federal, State, and Local regulations/codes.

This manual includes instructions and parts information for a variety of end truck types. Therefore, all instructions and parts information may not apply to any one type or size of specific end truck. Disregard those portions of the instructions that do not apply.

Record your end truck's Model Type and Serial Number on the front cover of this manual for identification and future reference to avoid referring to the wrong manual for information or instructions on installation, operation, inspection, maintenance, or parts.

Use only Harrington authorized replacement parts in the service and maintenance of your Harrington end trucks.

WARNING

Equipment described herein is not designed for and **MUST NOT** be used for lifting, supporting, or transporting people, or for lifting or supporting loads over people.

Equipment described herein should not be used in conjunction with other equipment unless necessary and/or required safety devices applicable to the system, crane, or application are installed by the system designer, system manufacturer, crane manufacturer, installer, or user.

Modifications to upgrade, rerate, or otherwise alter this equipment shall be authorized only by the original equipment manufacturer.

Equipment described herein may be used in the design and manufacture of cranes or monorails. Additional equipment or devices may be required for the crane and monorail to comply with applicable crane design and safety standards. The crane designer, crane manufacturer, or user is responsible to furnish these additional items for compliance. Refer to ANSI/ASME B30.16, Safety Standard for Overhead Hoists; ANSI/ASME B30.2 Safety Standard for Top-Running Double-Girder Cranes; and ANSI/ASME B30.11 Safety Standard for Underhung Cranes and Monorails.

If a below-the-hook lifting device or sling is used with a hoist, refer to ANSI/ASME B30.9, Safety Standard for Slings, or ANSI/ASME B30.20, Safety Standard for Below-the-Hook Lifting Devices.

Hoists and cranes, used to handle hot molten material may require additional equipment or devices. Refer to ANSI Z241.2, Safety Requirements for Melting and Pouring of Metals in the Metalcasting Industry.

Failure to read and comply with any one of the limitations noted herein can result in serious bodily injury or death, and/or property damage.

WARNING

HAZARDOUS ELECTRICAL POWER IS PRESENT IN THE END TRUCK MOTOR, IN THE SUPPLY OF ELECTRICAL POWER TO THE END TRUCK MOTOR, AND IN THE CONNECTIONS BETWEEN COMPONENTS.

Before performing ANY maintenance on the equipment, de-energize the electrical supply to the equipment, and lock and tag the supply device in the de-energized position. Refer to ANSI Z244.1, "Personnel Protection - Lockout/Tagout of Energy Sources."

Only trained and competent personnel should inspect and repair this equipment.

NOTICE

It is the responsibility of the owner/user to install, inspect, test, maintain, and operate the equipment covered by this manual in accordance with the applicable ANSI/ASME B30 volume(s) and OSHA Regulations.

It is the responsibility of the owner/user to have all personnel that will install, inspect, test, maintain, and operate the equipment covered by this manual read the contents of this manual and applicable portions of ANSI/ASME B30 volume(s), and OSHA Regulations.

If the owner/user of the equipment covered by this manual requires additional information, or if any information in the manual is not clear, contact Harrington or the distributor of the end truck. Do not install, inspect, test, maintain, or operate this equipment unless this information is fully understood.

A regular schedule of inspection of the equipment in accordance with the requirements of ANSI/ASME B30 volume(s) should be established and records maintained.

NOTICE

Responsibility for cranes using Harrington Series 3 End Trucks:

- For cranes where HARRINGTON fabricates the bridge, Harrington is responsible for the design of the crane based on information supplied by the customer at the time of order.
- For cranes where OTHERS fabricate the bridge, the customer or fabricator is responsible for the design of the crane.

1.2 Warning Tags and Labels

The End Trucks covered by this owner's manual may be used as part of a lifting system such as a crane. It is the responsibility of the supplier and the owner of such a lifting system to provide for and ensure that the lifting system be equipped with warning labels in accordance with applicable industry standards.

2.0 Technical Information

2.1 Specifications for Underhung End Trucks

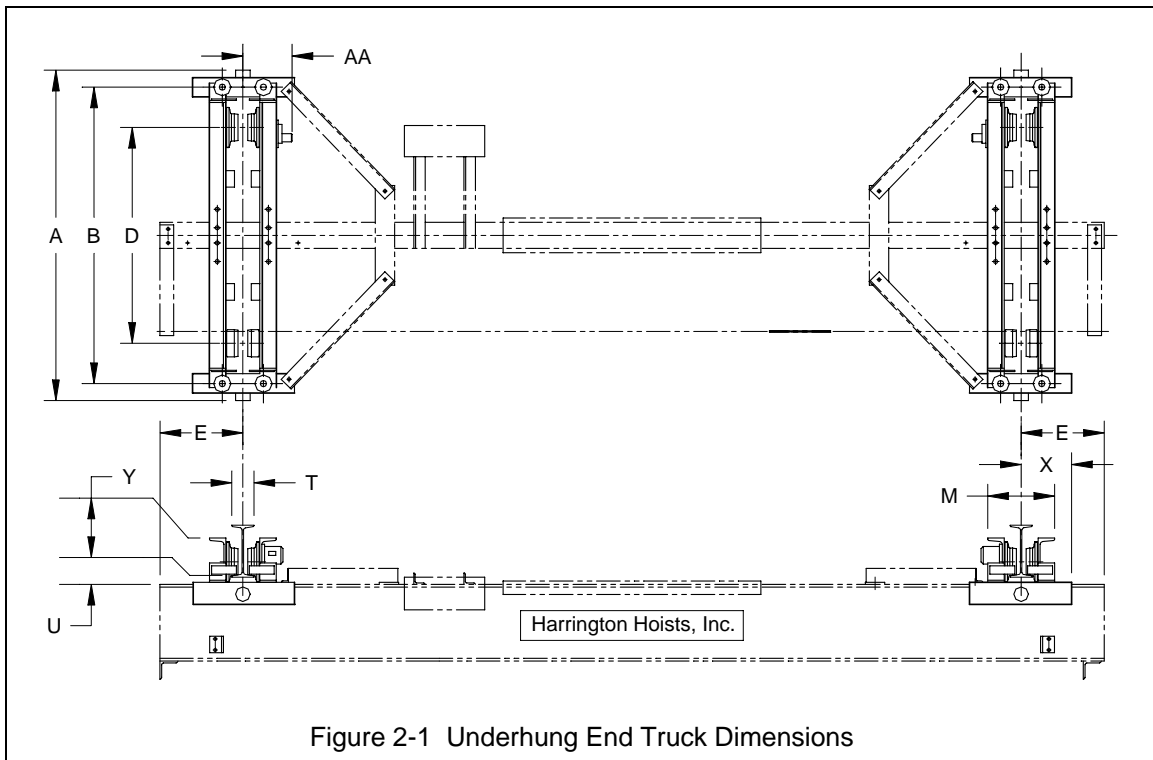

Figure 2-1 Underhung End Truck Dimensions

Underhung Push (Manual) End Trucks (Refer to Fig. 2-1)													
Max. Cap. (Tons)	Max. Span (ft)	End Truck Model #	Wheel Dia. (in)	Flange Range Std. (in)	A Overall Length (in)	B Roller Base (in)	D Wheel Base (in)	E * Beam Beyond Span (in)	M End Truck Frame Width (in)	U ** Wheel Bottom to Beam Top (in)	X Width Beyond Span (in)	Y Height (in)	End Truck Weight (lbs/pr)
2	35	UP-3-0235	4.33	3 - 6	60	53	39	12	T+8.1	1.8	11.3-T/2	6.5	448
2	45	UP-3-0245	4.33	3 - 6	82	75	61	12	T+8.1	1.8	11.3-T/2	6.5	585
3	35	UP-3-0335	4.92	3 - 6	60	53	35	12	T+8.2	1.9	11.3-T/2	6.5	472
5	35	UP-3-0535	5.51	4 - 6	60	53	33	12	T+9.8	2.0	11.3-T/2	6.4	546

* minimum overhang is M/2

** includes 3/8" thick beam mounting plates

Underhung Geared End Trucks (Refer to Fig. 2-1)

Max. Cap. (Tons)	Max. Span (ft)	End Truck Model #	Wheel Dia. (in)	Flange Range Std. (in)	A Overall Length (in)	B Roller Base (in)	D Wheel Base (in)	E * Beam Beyond Span (in)	J Hand Wheel Offset (in)	M End Truck Frame Width (in)	U ** Wheel Bottom to Beam Top (in)	X Width Beyond Span (in)	Y Wheel Running Surface to Upper Most Part of ET (in)	End Truck Weight (lbs/pr)
2	35	UG-3-0235	4.33	3 - 6	60	53	39	12	T/2+9.0	T+8.1	1.8	11.3-T/2	6.5	503
2	45	UG-3-0245	4.33	3 - 6	82	75	61	12	T/2+9.0	T+8.1	1.8	11.3-T/2	6.5	640
3	35	UG-3-0335	4.92	3 - 6	60	53	35	12	T/2+8.9	T+8.2	1.9	11.3-T/2	6.7	529
3	45	UG-3-0345	4.92	3 - 6	82	75	57	12	T/2+8.9	T+8.2	1.9	11.3-T/2	6.7	666
5	35	UG-3-0535	5.51	4 - 6	60	53	33	12	T/2+9.0	T+9.8	2.0	11.3-T/2	6.8	611
5	45	UG-3-0545	5.51	4 - 6	82	75	55	12	T/2+9.0	T+9.8	2.0	11.3-T/2	6.8	768

* minimum overhang is M/2

** includes 3/8" thick beam mounting plates

Underhung Motorized End Trucks (Refer to Fig. 2-1)													
Max. Cap. (Tons)	Max. Span (ft)	End Truck Model #	Wheel Dia. (in)	Flange Range Std. (in)	A Overall Length (in)	B Roller Base (in)	D Wheel Base (in)	E * Beam Beyond Span (in)	M End Truck Frame Width (in)	U ** Wheel Bottom to Beam Top (in)	X Width Beyond Span (in)	Y Wheel Running Surface to Upper Most Part of ET (in)	AA Span to Motor End (in)
2	35	UML/S/H/D-3-0235	4.33	3 - 6	60	53	39	12	T+8.1	1.8	11.3-T/2	6.5	T/2+11.9 (L/S)
2	50	UML/S/H/D-3-0250	4.33	3 - 6	82	75	61	12	T+8.1	1.8	11.3-T/2	6.5	T/2+12.3 (H)
3	35	UML/S/H/D-3-0335	4.92	3 - 6	60	53	35	12	T+8.2	1.9	11.3-T/2	6.5	T/2+13.3 (D)
3	50	UML/S/H/D-3-0350	4.92	3 - 6	82	75	57	12	T+8.2	1.9	11.3-T/2	6.5	T/2+13.7 (L/S/D)
5	35	UML/S/H/D-3-0535	5.51	4 - 6	60	53	33	12	T+9.8	2.0	11.3-T/2	6.8	T/2+14.2 (H)
5	50	UML/S/H/D-3-0550	5.51	4 - 6	82	75	55	12	T+9.8	2.0	11.3-T/2	6.8	

* minimum overhang is M/2

** includes 3/8" thick beam mounting plates

Underhung Motorized End Truck - Gear Motors														
End Truck Model #	Travel Speed (FPM)	Motor Power (Hp) Ea. of Two	Current (AMPS) Ea. of Two		Travel Speed (FPM)	Motor Power (Hp) Ea. of Two	Current (AMPS) Ea. of Two		Travel Speed (FPM)	Motor Power (Hp) Ea. of Two	Current (AMPS) Ea. of Two		Motor End Truck Weight (lbs./pr)	
			230V	460V			230V	460V			230V	460V		
UML/S/H/D-3-0235	40/80	0.33	1.6	1.0	120	0.5	2.1	1.3	80/20	0.33/0.10	1.6/1.1	0.9/0.8	522	
UML/S/H/D-3-0250	40/80	0.33	1.6	1.0	120	0.5	2.1	1.3	80/20	0.33/0.10	1.6/1.1	0.9/0.8	659	
UML/S/H/D-3-0335	40/80	0.33	1.6	1.0	120	0.5	2.1	1.3	80/20	0.33/0.10	1.6/1.1	0.9/0.8	543	
UML/S/H/D-3-0350	40/80	0.33	1.6	1.0	120	0.5	2.1	1.3	80/20	0.33/0.10	1.6/1.1	0.9/0.8	680	
UML/S/H/D-3-0535	40/80	0.50	2.1	1.3	120	1.0	3.3	2.0	80/20	0.50/0.13	2.0/1.5	1.2/0.9	638	
UML/S/H/D-3-0550	40/80	0.50	2.1	1.3	120	1.0	3.3	2.0	80/20	0.50/0.13	2.0/1.5	1.2/0.9	795	

Speed Code

- L - Designates the speed of 40 feet per minute
- S - Designates the speed of 80 feet per minute
- H - Designates the speed of 120 feet per minute
- D - Designates the speed of dual speed 80/20 feet per minute

Product code derivation - example: UML/S/H/D-3-0235

U - Underhung

M - Motorized

L/S/H/D - Speed code - available in 40, 80, 120, or dual 80/20 feet per minute - choose desired speed

3 - Series number

02 - Capacity - 2 ton

35 - Maximum span - 35 feet

Max-E-Lift Underhung Geared End Trucks (Refer to Fig. 2-1)

Max. Cap. (tons)	Max. Span (ft)	End Truck Model #	Wheel Diameter (in)	Flange Range Std. (in)	A Overall Length (in)	B Roller Base (in)	D Wheel Base (in)	E * Beam Beyond Span (in)	J Hand Wheel Offset (in)	M End Truck Frame Width (in)	U ** Wheel Bottom to Beam Top (in)	X Width Beyond Span (in)	Y Wheel Running Surface to Upper Most Part of ET (in)	End Truck Weight (lbs/pr)
2	35	MUG-3-0235	4.33	3 - 6	87	80	66	12	T/2+9.0	T+8.1	1.8	11.3-T/2	6.5	671
2	45	MUG-3-0245	4.33	3 - 6	99	92	78	12	T/2+9.0	T+8.1	1.8	11.3-T/2	6.5	746
3	35	MUG-3-0335	4.92	3 - 6	91	84	66	12	T/2+8.9	T+8.2	1.9	11.3-T/2	6.7	722
3	45	MUG-3-0345	4.92	3 - 6	103	96	78	12	T/2+8.9	T+8.2	1.9	11.3-T/2	6.7	797
5	35	MUG-3-0535	5.51	4 - 6	95	88	68	12	T/2+9.0	T+9.8	2.0	11.3-T/2	6.8	861
5	45	MUG-3-0545	5.51	4 - 6	107	100	80	12	T/2+9.0	T+9.8	2.0	11.3-T/2	6.8	946

* minimum overhang is M/2

** includes 3/8" thick beam mounting plates

Max-E-Lift Underhung Motorized End Trucks (Refer to Fig. 2-1)

Max. Cap. (Tons)	Max. Span (ft)	End Truck Model #	Whl. Dia. (in)	Flange Range Std. (in)	A Overall Length (in)	B Roller Base (in)	D Wheel Base (in)	E * Beam Beyond Span (in)	M End Truck Frame Width (in)	U ** Wheel Bottom to Beam Top (in)	X Width Beyond Span (in)	Y Wheel Running Surface to Upper Most Part of ET (in)	AA Span to Motor End (in)
2	35	MUML/S/H/D-3-0235	4.33	3 - 6	87	80	66	12	T+8.1	1.8	11.3-T/2	6.5	T/2+11.9 (L/S)
2	50	MUML/S/H/D-3-0250	4.33	3 - 6	99	92	78	12	T+8.1	1.8	11.3-T/2	6.5	T/2+12.3 (H)
3	35	MUML/S/H/D-3-0335	4.92	3 - 6	91	84	66	12	T+8.2	1.9	11.3-T/2	6.5	T/2+13.3 (D)
3	50	MUML/S/H/D-3-0350	4.92	3 - 6	103	96	78	12	T+8.2	1.9	11.3-T/2	6.5	T/2+13.7 (L/S/D)
5	35	MUML/S/H/D-3-0535	5.51	4 - 6	95	88	68	12	T+9.8	2.0	11.3-T/2	6.8	T/2+14.2 (H)
5	50	MUML/S/H/D-3-0550	5.51	4 - 6	107	100	80	12	T+9.8	2.0	11.3-T/2	6.8	

* minimum overhang is M/2

** includes 3/8" thick beam mounting plates

Max-E-Lift Underhung Motorized End Truck - Gear Motors

End Truck Model #	Travel Speed (FPM)	Motor Power (Hp) Ea. of Two	Current (AMPS) Ea. of Two		Travel Speed (FPM)	Motor Power (Hp) Ea. of Two	Current (AMPS) Ea. of Two		Travel Speed (FPM)	Motor Power (Hp) Ea. of Two	Current (AMPS) Ea. of Two		Motor End Truck Weight (lbs/pr)
			230V	460V			230V	460V			230V	460V	
			MUML/S/H/D-3-0235	40/80			0.33	1.6			1.0	120	
MUML/S/H/D-3-0250	40/80	0.33	1.6	1.0	120	0.5	2.1	1.3	80/20	0.33/0.10	1.6/1.1	0.9/0.8	765
MUML/S/H/D-3-0335	40/80	0.33	1.6	1.0	120	0.5	2.1	1.3	80/20	0.33/0.10	1.6/1.1	0.9/0.8	736
MUML/S/H/D-3-0350	40/80	0.33	1.6	1.0	120	0.5	2.1	1.3	80/20	0.33/0.10	1.6/1.1	0.9/0.8	811
MUML/S/H/D-3-0535	40/80	0.50	2.1	1.3	120	1.0	3.3	2.0	80/20	0.50/0.13	2.0/1.5	1.2/0.9	888
MUML/S/H/D-3-0550	40/80	0.50	2.1	1.3	120	1.0	3.3	2.0	80/20	0.50/0.13	2.0/1.5	1.2/0.9	973

Speed Code

- L - Designates the speed of 40 feet per minute
- S - Designates the speed of 80 feet per minute
- H - Designates the speed of 120 feet per minute
- D - Designates the speed of dual speed 80/20 feet per minute

Product code derivation - example: MUML/S/H/D-3-0235

M - Max-E

U - Underhung

M - Motorized

L/S/H/D - Speed code - available in 40, 80, 120, or dual 80/20 feet per minute - choose desired speed

3 - Series number

02 - Capacity - 2 ton

35 - Maximum span - 35 feet

2.2 Specifications for Top Running End Trucks

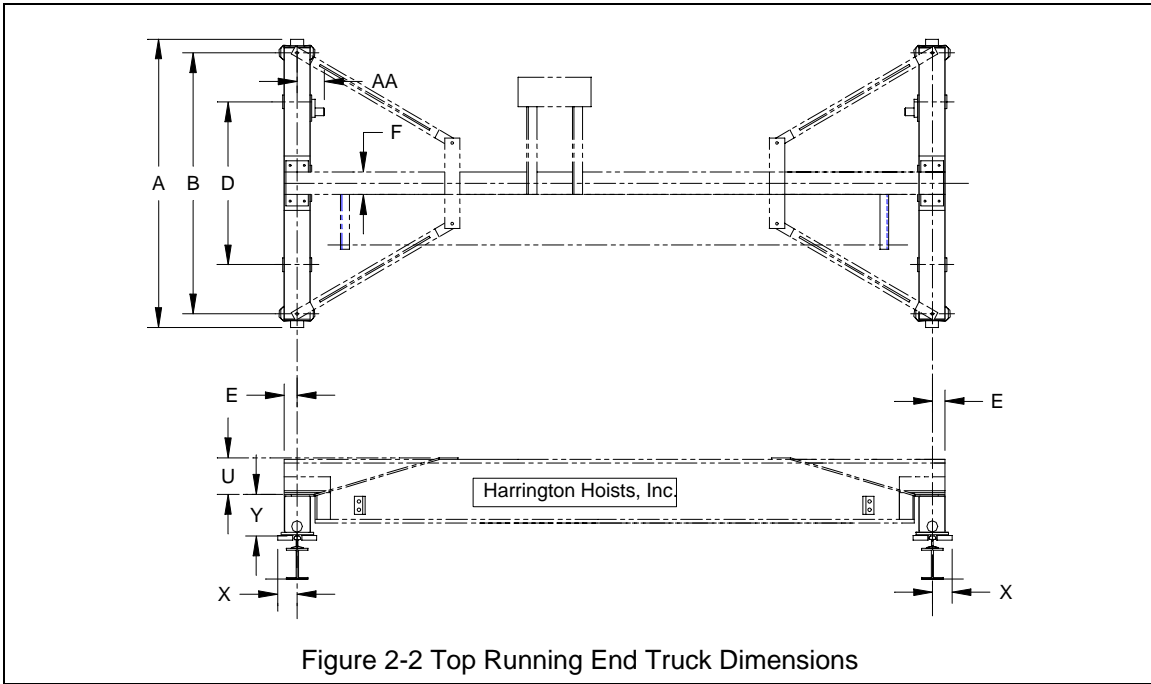

Top Running Push (Manual) End Trucks (Refer to Fig. 2-2)												
Max. Cap. (tons)	Max. Span (ft)	End Truck Model #	Wheel Diameter (in)	Sug. Min. Runway Rail (ACSE#)	A Overall Length (in)	B Roller Base (in)	D Wheel Base (in)	E Beam Beyond Span (in)	U Crane Height Above End Truck (in)	X* Width Beyond Span (in)	Y Top of Rail to Top of End Truck (in)	End Truck Weight (lbs./pr)
1	35	TP-3-0135	3.74	30	61	53	43	2.4	8.4**	4.6	7.1	228
1	45	TP-3-0145	3.74	30	98	90	80	2.4	8.4**	4.6	7.1	324
2	45	TP-3-0245	6.10	30	99	91	80	4.1	8.4**	4.6	7.1	455
3	35	TP-3-0335	6.10	30	62	54	43	4.1	8.4**	4.6	7.1	337
5	35	TP-3-0535	6.10	40	62	54	43	4.1	8.5	4.7	9.2	410

* Based on suggested minimum runway rail.

** 10.4" for cranes using a 10" beam

Top Running Geared End Trucks (Refer to Fig. 2-2)													
Max. Cap. (tons)	Max. Span (ft)	End Truck Model #	Wheel Diameter (in)	Suggested Min. Runway Rail (ACSE#)	A Overall Length (in)	B Roller Base (in)	D Wheel Base (in)	E Beam Beyond Span (in)	J Hand Wheel Offset (in)	U Crane Height Above End Truck (in)	X* Width Beyond Span (in)	Y Top of Rail to Top of End Truck (in)	End Truck Weight (lbs.)
1	35	TG-3-0135	3.74	30	61	53	43	2.4	9.7	8.4**	4.6	7.1	258
1	50	TG-3-0150	3.74	30	98	90	80	2.4	9.7	8.4**	4.6	7.1	354
3	35	TG-3-0335	6.10	30	62	54	43	4.1	10.0	8.4**	4.6	7.1	353
3	50	TG-3-0350	6.10	30	99	91	80	4.1	10.0	8.4**	4.6	7.1	470
5	35	TG-3-0535	6.10	40	62	54	43	4.1	10.0	8.5	4.7	9.2	433
5	50	TG-3-0550	8.27	40	99	90	74	3.9	10.3	8.5	4.7	9.3	683

* Based on suggested minimum runway rail.

** 10.4" for cranes using a 10" beam

Top Running Motorized End Trucks (Refer to Fig. 2-2)

Max. Cap. (tons)	Max. Span (ft)	End Truck Model #	Wheel Diameter (in)	Sug. Min. Runway Rail (ACSE#)	A Overall Length (in)	B Roller Base (in)	D Wheel Base (in)	E Beam Beyond Span (in)	U Crane Height Above End Truck (in)	X* Width Beyond Span (in)	Y Top of Rail to Top of End Truck (in)	AA Span to Motor End (in)
1	35	TML/S/H/D-3-0135	3.74	30	61	53	43	2.4	8.4**	4.6	7.1	12.7 (L/S)
1	60	TML/S/H/D-3-0160	3.74	30	98	90	80	2.4	8.4**	4.6	7.1	13.1 (H) 14.0 (D)
3	35	TML/S/H/D-3-0335	6.10	30	62	54	43	4.1	8.4**	4.6	7.1	13.0 (L/S)
3	60	TML/S/H/D-3-0360	6.10	30	99	91	80	4.1	8.4**	4.6	7.1	13.4 (H)
5	35	TML/S/H/D-3-0535	6.10	40	62	54	43	4.1	8.5	4.7	9.2	14.3 (D)
5	60	TML/S/H/D-3-0560	8.27	40	99	90	74	3.9	8.5	4.7	9.3	15.0 (L/S/D) 15.4 (H)
10	35	TML/S/H/D-3-1035	9.84	60	63	53	37	6.0	12.5	6.3	11.3	17.4 (L/S/D)
10	60	TML/S/H/D-3-1060	9.84	60	100	90	74	6.0	12.5	6.3	11.3	18.7 (H)

* Based on suggested minimum runway rail.

** 10.4" for cranes using a 10" beam

Top Running Motorized End Truck - Gear Motors													
End Truck Model #	Travel Speed (FPM)	Motor Power (Hp) Ea. of Two	Current (AMPS) Ea. of Two		Travel Speed (FPM)	Motor Power (Hp) Ea. of Two	Current (AMPS) Ea. of Two		Travel Speed (FPM)	Motor Power (Hp) Ea. of Two	Current (AMPS) Ea. of Two		Motor End Truck Weight (lbs./pr)
			230V	460V			230V	460V			230V	460V	
TML/S/H/D-3-0135	40/80	0.33	1.6	1.0	120	0.5	2.1	1.3	80/20	0.33/0.10	1.6/1.1	0.9/0.8	288
TML/S/H/D-3-0160	40/80	0.33	1.6	1.0	120	0.5	2.1	1.3	80/20	0.33/0.10	1.6/1.1	0.9/0.8	384
TML/S/H/D-3-0335	40/80	0.33	1.6	1.0	120	0.5	2.1	1.3	80/20	0.33/0.10	1.6/1.1	0.9/0.8	462
TML/S/H/D-3-0360	40/80	0.33	1.6	1.0	120	0.5	2.1	1.3	80/20	0.33/0.10	1.6/1.1	0.9/0.8	579
TML/S/H/D-3-0535	40/80	0.33	1.6	1.0	120	0.5	2.1	1.3	80/20	0.33/0.10	1.6/1.1	0.9/0.8	542
TML/S/H/D-3-0560	40/80	0.50	2.1	1.3	120	1.0	3.3	2.0	80/20	0.50/0.13	2.0/1.5	1.2/0.9	712
TML/S/H/D-3-1035	40/80	1.00	3.3	2.0	120	2.0	5.8	3.1	80/20	1.00/0.25	3.7/2.1	2.3/1.4	906
TML/S/H/D-3-1060	40/80	1.00	3.3	2.0	120	2.0	5.8	3.1	80/20	1.00/0.25	3.7/2.1	2.3/1.4	1086

* Based on suggested minimum runway rail.

Speed Code

- L - Designates the speed of 40 feet per minute
- S - Designates the speed of 80 feet per minute
- H - Designates the speed of 120 feet per minute
- D - Designates the speed of dual speed 80/20 feet per minute

Product code derivation - example: TML/S/H/D-3-0135

T - Top Running

M - Motorized

L/S/H/D - Speed code - available in 40, 80, 120, or dual 80/20 feet per minute - choose desired speed

3 - Series number

01 - Capacity - 1 ton

35 - Maximum span - 35 feet

Max-E-Lift Top Running Geared End Trucks (Refer to Fig. 2-2)													
Max. Cap. (tons)	Max. Span (ft)	End Truck Model #	Wheel Diameter (in)	Sug. Min. Runway Rail (ASCE#)	A Overall Length (in)	B Roller Base (in)	D Wheel Base (in)	E Beam Beyond Span (in)	J Hand Wheel Offset (in)	K Beam Gauge (in)	W* Width Beyond Span (in)	Y Top of Rail to Top of End Truck (in)	End Truck Weight (lbs./pr)
1	35	MTG-3-0135	3.74	30	72	64	54	2.06	9.7	36	4.6	7.1	310
1	50	MTG-3-0150	3.74	30	111	103	93	2.06	9.7	36	4.6	7.1	411
3	35	MTG-3-0335	6.10	30	75	67	56	3.75	10.0	36	4.6	7.1	417
3	50	MTG-3-0350	6.10	30	112	104	93	3.75	10.0	36	4.6	7.1	538
5	35	MTG-3-0535	6.10	40	75	67	56	3.75	10.0	36	4.7	9.2	539
5	50	MTG-3-0550	8.27	40	112	103	87	3.50	10.3	36	4.7	9.3	789

Max-E-Lift Top Running Motorized End Trucks (Refer to Fig. 2-2)

Max. Cap. (Tons)	Max. Span (ft)	End Truck Model #	Wheel Diameter (in)	Sug. Min. Runway Rail (ASCE#)	A Overall Length (in)	B Roller Base (in)	D Wheel Base (in)	E Beam Beyond Span (in)	K Beam Gauge (in)	W * Width Beyond Span (in)	Y Top of Rail to Top of End Truck (in)	AA Span to Motor End (in)
1	35	MTML/S/H/D-3-0135	3.74	30	72	64	54	2.06	36	4.6	7.1	12.7 (L/S)
1	60	MTML/S/H/D-3-0160	3.74	30	111	103	93	2.06	36	4.6	7.1	13.1 (H) 14.0 (D)
3	35	MTML/S/H/D-3-0335	6.10	30	75	67	56	3.75	36	4.6	7.1	13.0 (L/S)
3	60	MTML/S/H/D-3-0360	6.10	30	112	104	93	3.75	36	4.6	7.1	13.4 (H)
5	35	MTML/S/H/D-3-0535	6.10	40	75	67	56	3.75	36	4.7	9.2	14.3 (D)
5	60	MTML/S/H/D-3-0560	8.27	40	112	103	87	3.50	36	4.7	9.3	15.0 (L/S/D) 15.4 (H)
10	35	MTML/S/H/D-3-1035	9.84	60	93	83	67	5.25	48	6.3	11.3	17.4 (L/S/D)
10	60	MTML/S/H/D-3-1060	9.84	60	113	103	87	5.25	48	6.3	11.3	18.7 (H)

Max-E Top Running Motorized End Truck - Gear Motors

End Truck Model #	Travel Speed (FPM)	Motor Power (Hp) Ea. of Two	Current (AMPS) Ea. of Two		Travel Speed (FPM)	Motor Power (Hp) Ea. of Two	Current (AMPS) Ea. of Two		Travel Speed (FPM)	Motor Power (Hp) Ea. of Two	Current (AMPS) Ea. of Two		Motor End Truck Weight (lbs./pr)
			230V	460V			230V	460V			230V	460V	
			MTML/S/H/D-3-0135	40/80			0.33	1.6			1.0	120	
MTML/S/H/D-3-0160	40/80	0.33	1.6	1.0	120	0.5	2.1	1.3	80/20	0.33/0.10	1.6/1.1	0.9/0.8	441
MTML/S/H/D-3-0335	40/80	0.33	1.6	1.0	120	0.5	2.1	1.3	80/20	0.33/0.10	1.6/1.1	0.9/0.8	526
MTML/S/H/D-3-0360	40/80	0.33	1.6	1.0	120	0.5	2.1	1.3	80/20	0.33/0.10	1.6/1.1	0.9/0.8	647
MTML/S/H/D-3-0535	40/80	0.33	1.6	1.0	120	0.5	2.1	1.3	80/20	0.33/0.10	1.6/1.1	0.9/0.8	648
MTML/S/H/D-3-0560	40/80	0.50	2.1	1.3	120	1.0	3.3	2.0	80/20	0.50/0.13	2.0/1.5	1.2/0.9	818
MTML/S/H/D-3-1035	40/80	1.00	3.3	2.0	120	2.0	5.8	3.1	80/20	1.00/0.25	3.7/2.1	2.3/1.4	1105
MTML/S/H/D-3-1060	40/80	1.00	3.3	2.0	120	2.0	5.8	3.1	80/20	1.00/0.25	3.7/2.1	2.3/1.4	1202

2.3 Component Names

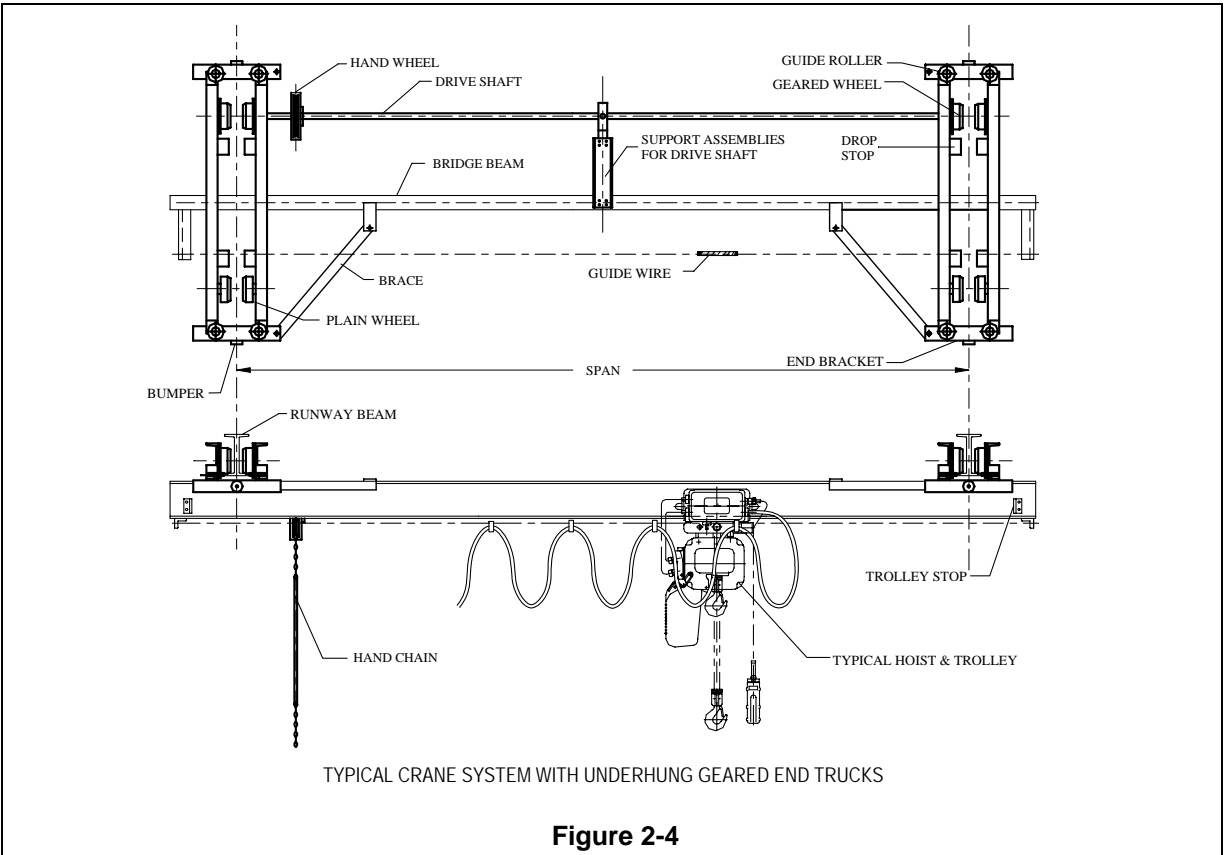
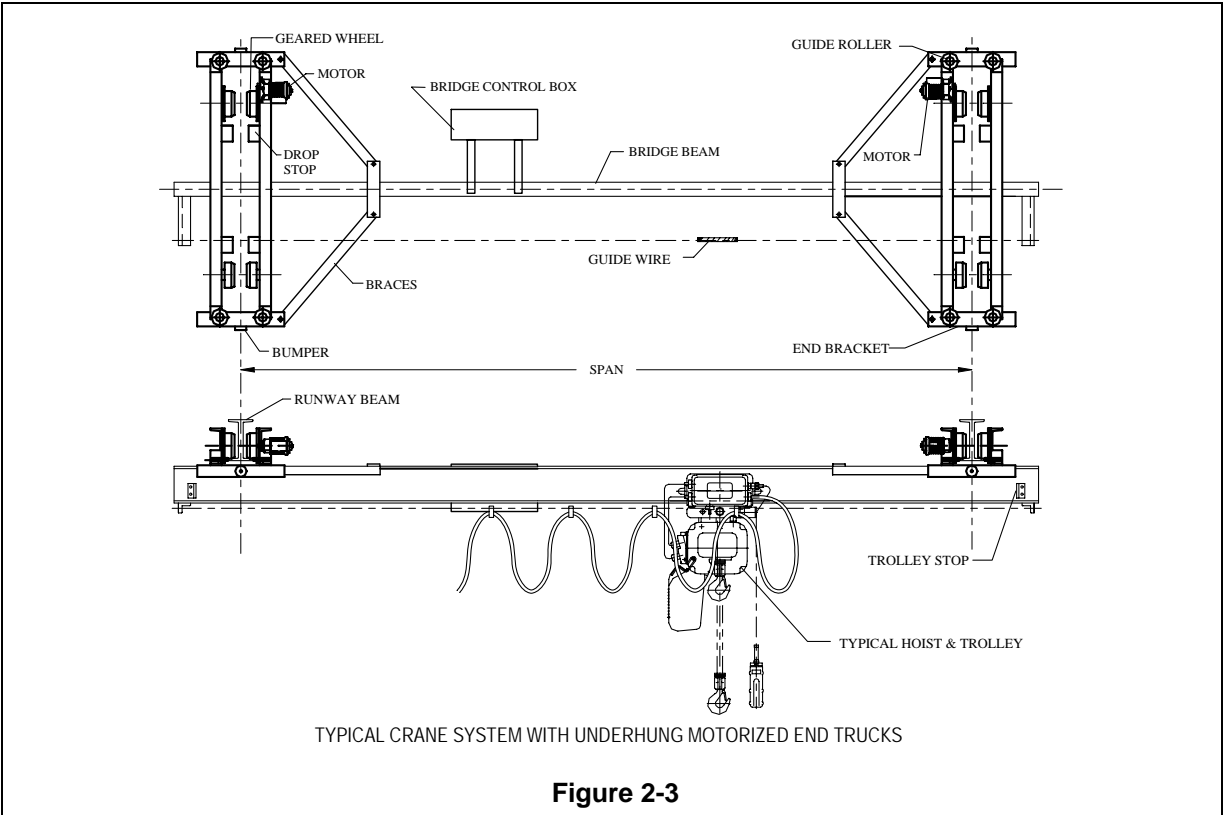

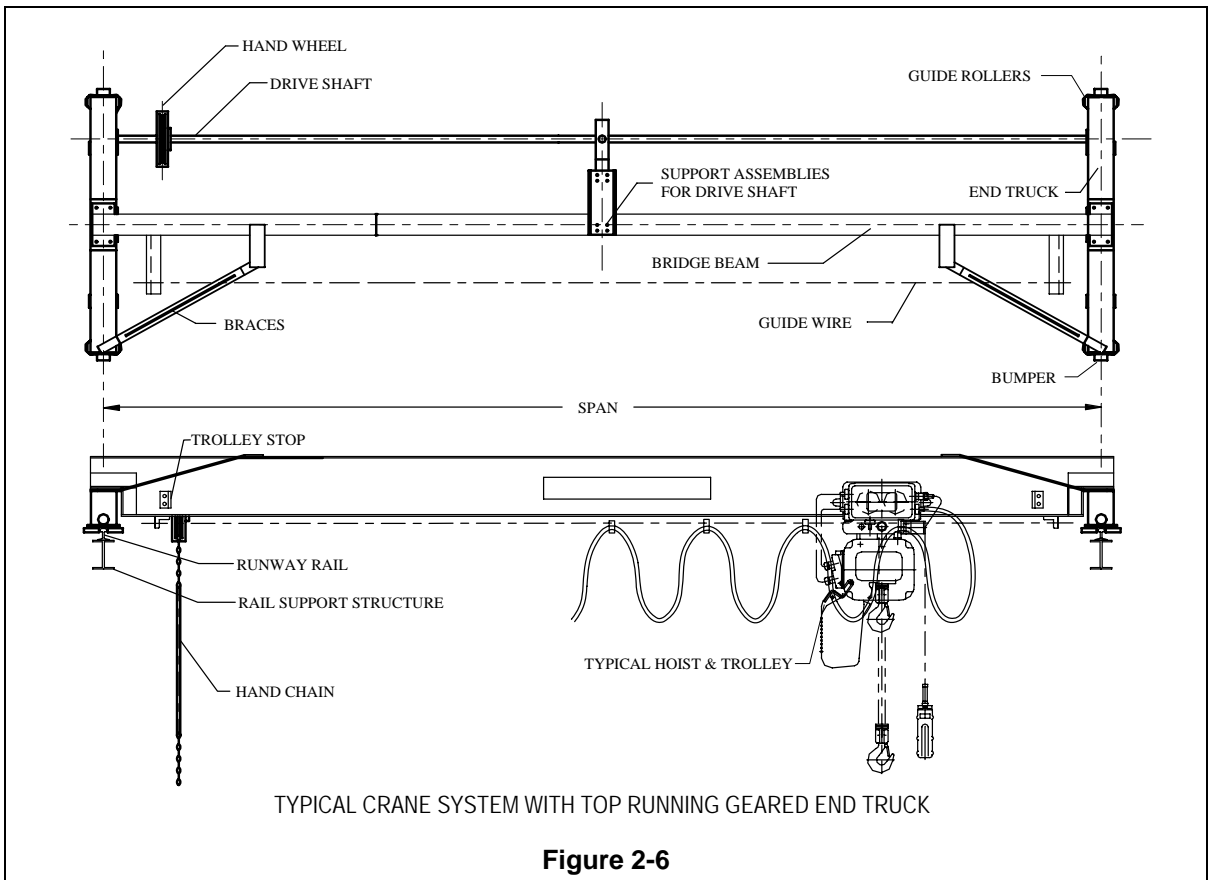
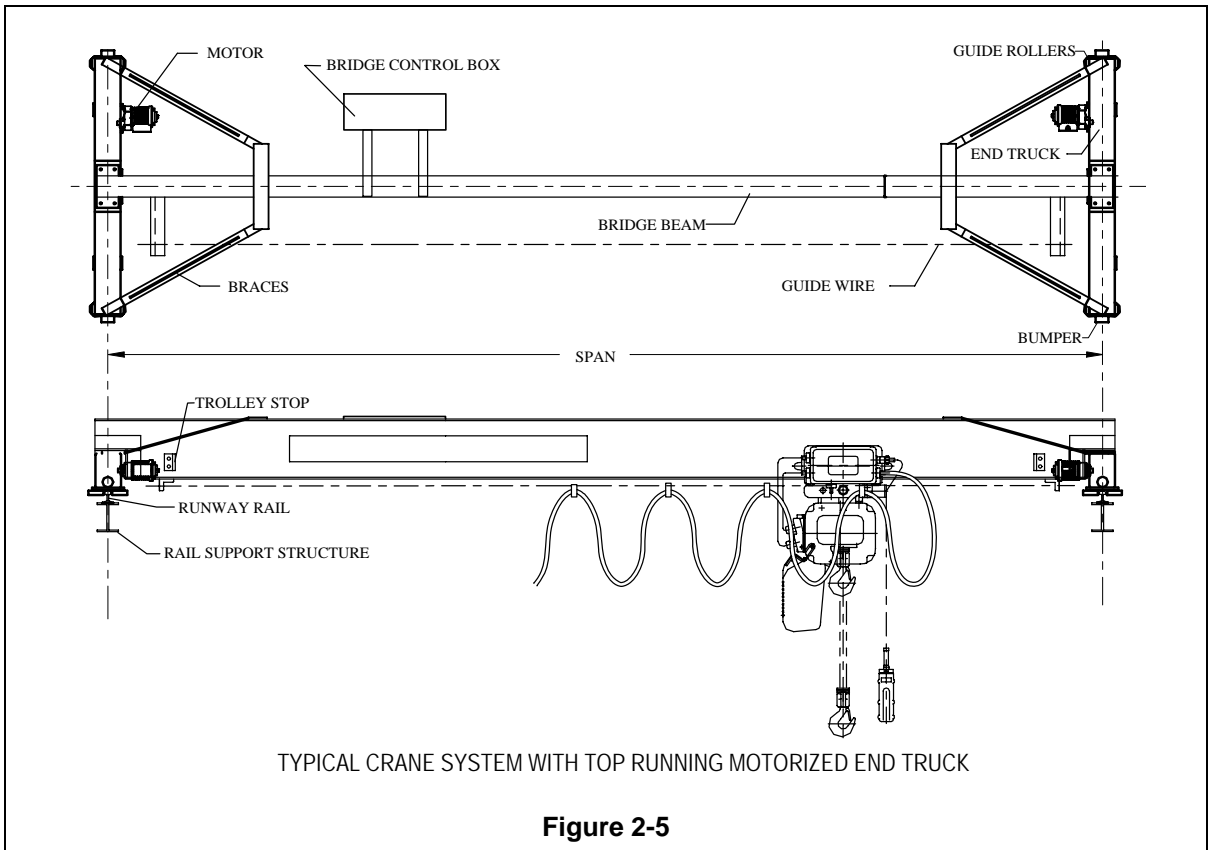

2.4 Bridge Crane Design Requirements - For proper selection of end trucks to meet your particular needs, refer to the Harrington brochure “Choosing the Crane to Fit Your Needs” or our latest catalog.

2.4.1 CRANE RUNWAYS



Supporting Structure - Ensure that the supporting structure for the runways is adequate. If necessary consult a professional that is qualified to evaluate the adequacy of the runway's supporting structure.

⚠ WARNING Installing a crane system on runways supported by inadequate supporting structure **could** result in **death or serious injury**, and property damage.

Runway Design - Ensure that the runways meet the design requirements of the CMAA Specification #70 or #74 whichever applies.

Runway Alignment - Ensure that the runways meet the runway alignment requirements of CMAA Specification #70 or #74, whichever applies. For your convenience, Harrington has provided these alignment criteria in [Table 2-1](#) below.

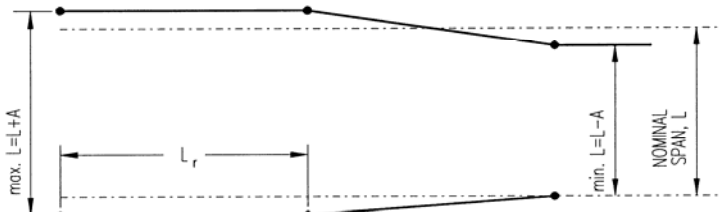
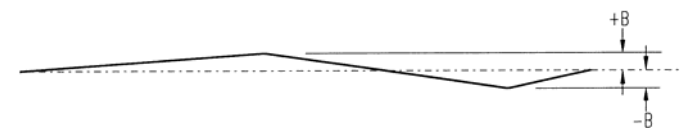
⚠ WARNING Improper design, fabrication, or installation of crane runways **could** result in **death or serious injury**, and property damage.

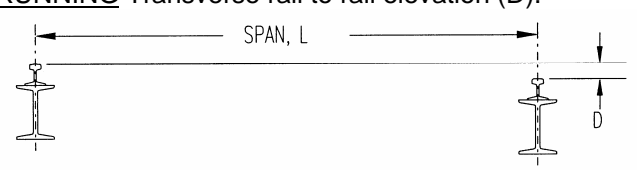
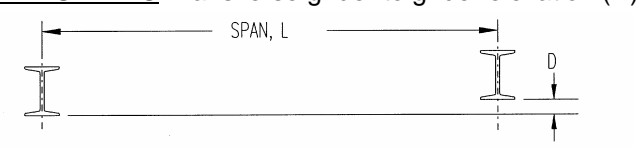
Table 2-1 CMAA Design Requirements		
Item	Overall Tolerance	Maximum Rate Of Change
Crane span (L) measured at crane wheel contact surface. 	$L < 50'$ $A = \frac{3}{16}"$ $50' < L < 100'$ $A = \frac{1}{4}"$ $L > 100'$ $A = \frac{3}{8}"$	$\frac{1}{4}"$ in 20'-0"
Straightness (B) 	$B = \frac{3}{8}"$	$\frac{1}{4}"$ in 20'-0"
Elevation (C) 	$C = \frac{3}{8}"$	$\frac{1}{4}"$ in 20'-0"
<u>TOP RUNNING</u> Transverse rail to rail elevation (D). 	$L < 50'$ $D = \frac{3}{16}"$ $50' < L < 100'$ $D = \frac{1}{4}"$ $L > 100'$ $D = \frac{3}{8}"$	$\frac{1}{4}"$ in 20'-0"
<u>UNDER RUNNING</u> Transverse girder to girder elevation (D). 		

2.4.2 End Trucks

a) Determining Dimensions

- (1) Underhung - Select the proper runway I-beam from Table 2-2. Be sure runway has enough strength to support the load.

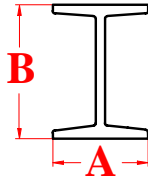
Table 2-2 Under Hung Runway I-Beam Dimensions		
		
END TRUCK CAPACITY	1 - 3 TON	5 TON
I-BEAM FLANGE WIDTH (A)	3" - 6"	4" - 6"
MINIMUM HEIGHT OF I-BEAM (B)	6"	8"

- (2) Top Running - Select the proper rail size from Table 2-3. Be sure runway has enough strength to support the load.

Table 2-3 Recommended A.S.C.E. Rail Sizes in Weight per Yard							
END TRUCK CAPACITY \ SPAN	1 TON	2 TON	3 TON	5 TON	8 TON	10 TON	
UP TO 35'	30	30	30	40	40	60	
35' TO 60'	30	30	30	40	40	60	

⚠ WARNING Improper installation or fit of end trucks to crane runways **could** result in **death or serious injury**, and property damage.

b) Cautions for Installation

- (1) Install the two crane runways horizontally and in parallel to within the following limits see Table 2-1.
- (2) Install the two crane runways vertically to within the following limits see Table 2-1.
- (3) Carefully select building beam or columns having sufficient strength to support crane runways securely.

2.4.3 Bridge

The end trucks covered by this manual are designed for use bridge beam assemblies fabricated according to the appropriate Harrington Bridge Beam Assembly Drawing, which use beams in accordance the tables below.

⚠️ WARNING

Improper design or fabrication of crane bridge beam assemblies **could** result in **death or serious injury**, and property damage.

- a) **Determining Dimensions** - Select the proper crane bridge based on capacity and span from Table 2-4 for single girder bridge cranes and Table 2-5 for double girder bridge cranes.

Table 2-4 BRIDGE BEAMS - Used for Harrington Crane Packages and Systems							
Capacity Tons Span Ft.	1/2	1	2	3	5	8	10
10	S8x18.4	S8x18.4	S10x25.4	S12x31.8	S12x40.8	W18x71	W21x93
15	S8x18.4	S8x18.4	S10x25.4	S12x40.8	S15x50	W21x83	W18x106
20	S8x18.4	S10x25.4	S12x31.8	S15x42.9	S15x42.9 C8x11.5	W21x93	W18x119
25	S10x25.4	S10x25.4	S12x31.8 C8x11.5	S15x42.9 C8x11.5	S15x42.9 C10x15.3	W24x103	W24x103 C12x20.7
30	S10x25.4	S12x31.8	S15x42.9	S15x42.9 C10x15.3	W16x77	W24x103	W27x129
35	S12x31.8	S15x42.9	S15x42.9 C8x11.5	W16x67	W21x83	W27x114	W30x148
40	S15x42.9	S15x42.9 C8x11.5	W18x60	W18x71	W21x83	W27x114 C12x20.7	W27x129 C15x33.9
45	S15x42.9 C8x11.5	W16x57	W18x71	W18x76	W24x94	W27x114 C15x33.9	W30x148 C15x33.9
50	W16x40	W18x60	W18x76	W21x83	W27x102	W30x124 C15x33.9	W30x148 C15x33.9
55	W16x57	W16x67	W21x83	W24x94	W27x114	W30x132 C15x33.9	W30x148 C15x33.9
60	W16x67	W18x76	W21x93	W27x114	W30x116 C15x33.9	W33x141 C15x33.9	W33x169 C15x33.9

- b) For double girder bridge beams consult factory.

This page intentionally left blank

3.0 Assembly, Installation and Trial Operation

⚠ WARNING Installing a crane system on runways supported by inadequate supporting structure *could* result in **death or serious injury**, and property damage.

⚠ WARNING Improper design, fabrication, or installation of crane runways *could* result in **death or serious injury**, and property damage.

NOTICE All operations associated with the assembly and installation of the crane system should be performed under the supervision of qualified personnel.

NOTICE Read through all steps completely before proceeding with installation.

3.1 Underhung End Trucks- (See Figure 3-1)

3.1.1 Before installing onto runway:

- a) Refer to Figure 3-1 and Figure 3-3. Separate frames A and B, and C and B of each end truck assembly from each other by removing the end brackets and, for geared and motorized end trucks, the pillow blocks, pinions, and collars.

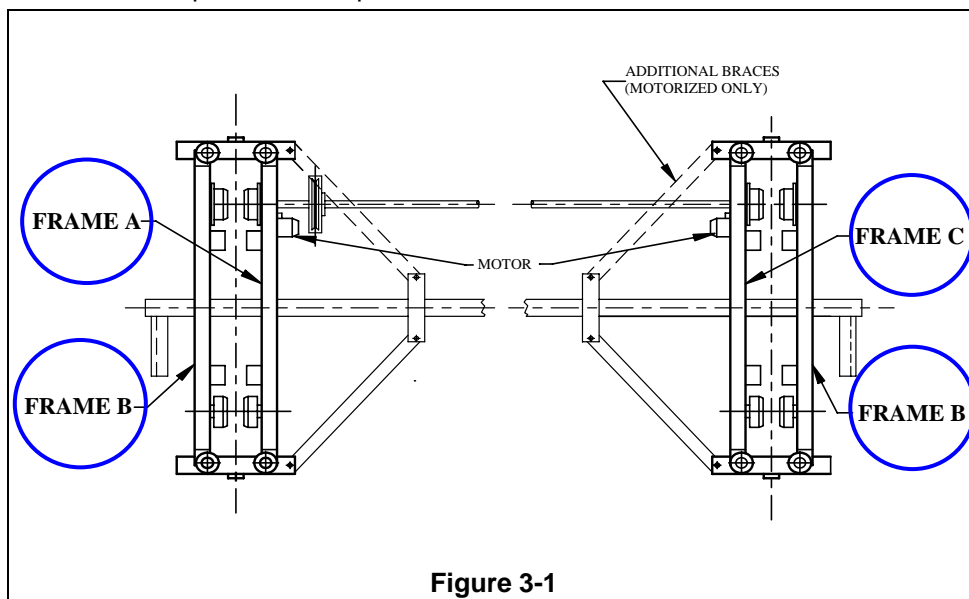

Figure 3-1

- b) Install frame A from one end truck onto the bridge beam, and secure it temporarily (see Figure 3-2). Note: if the end trucks were supplied as part of a Harrington crane system, complete with bridge beam, the end trucks are match-marked to the beam. In this case, ensure that end truck Frame A is installed to its match marked location on the bridge beam.
 - c) Install frame B on the crane bridge in the same manner as step (b) above, and secure it temporarily (see Figure 3-2).
- 3.1.2 Install the bridge beam assembly on to the runways per Figure 3-2. Be sure to use a temporary support method, which ensures that the crane assembly stays safely in the position depicted in Figure 3-2.

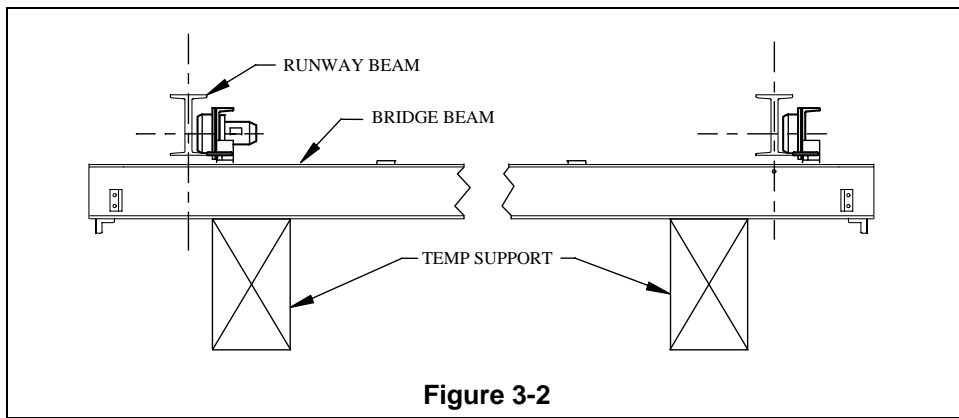

Figure 3-2

- 3.1.3 Install the remaining frames on the crane bridge and install the end brackets on both ends of the end trucks (See Figure 3-3). Install pinion shafts, pinions, and collars (See Figure 3-3). Geared and motorized only.

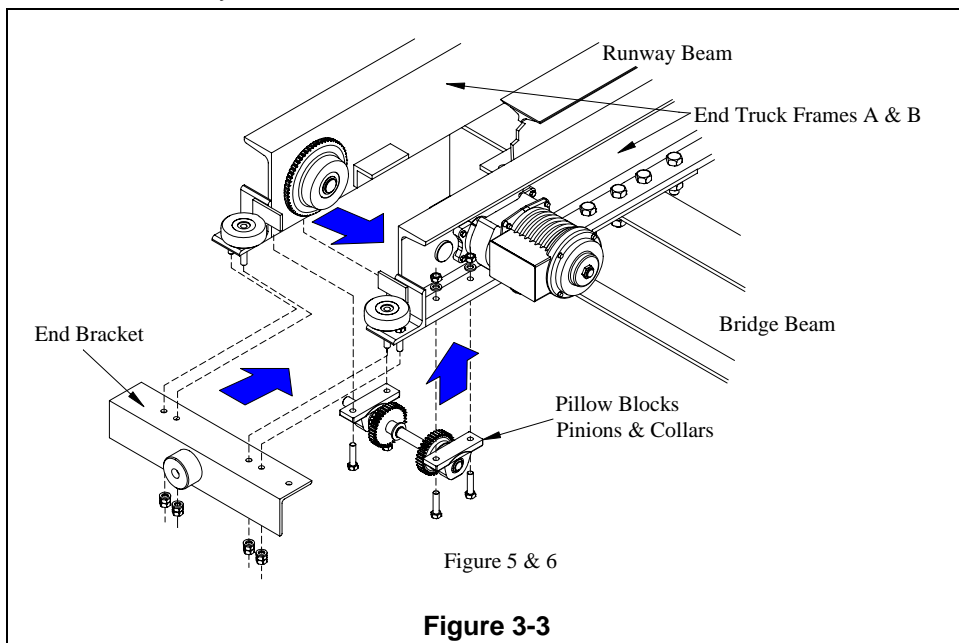
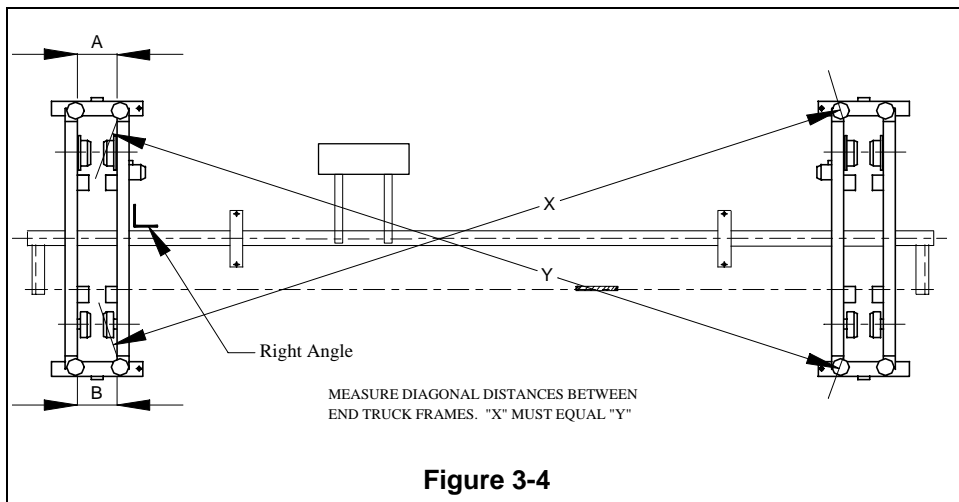

Figure 3-3

- 3.1.4 With the temporary support method of 3.1.2 above still in place refer to Figure 3-4 and check the following:
- End truck frames parallel; ($A = B$).
 - Bridge beam centered on each end truck.
 - Squareness of end trucks to the bridge beam; ($X = Y$).
- 3.1.5 Make adjustments as necessary. Then securely tighten and double nut each fastened connection of the end truck frames to bridge beam. Refer to tightening torque values of Table 3-1.

Bolt Size	M12	M14	M16	M20
Tightening Torque kg-cm (ft-lbs)		1150 (83)	2580 (187)	5070 (366)



- 3.1.6 Remove the temporary support method of 3.1.2 above. Move the crane along the full length of the runway. Check for binding and guide roller clearance (normal clearance is 3/16 inch from each guide roller to runway beam flange edge).
- 3.1.7 Install braces on the crane bridge and end trucks. Refer to Figure 3-5. Note: Figure 3-5 depicts a crane with two braces per end truck. Manual or Push crane systems require only one brace per end truck.

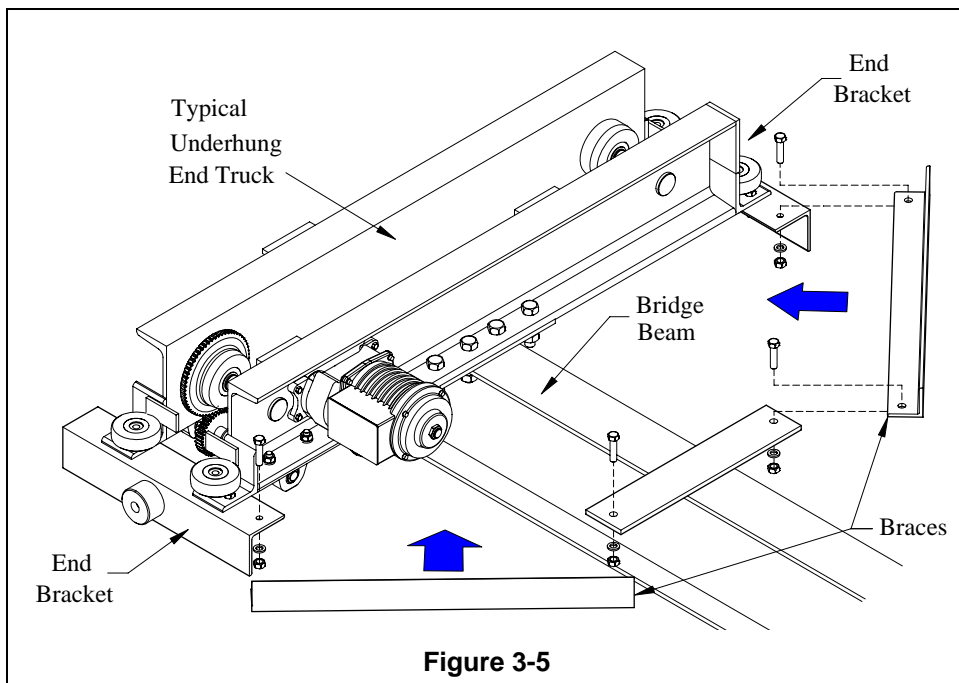

⚠ WARNING When installing the hoist and trolley on the bridge beam, refer to the installation instructions for your hoist and trolley. Failure to follow installation instructions *could* result in *death or serious injury*, and *property damage*.

3.2 Top Running End Trucks

- 3.2.1 Refer to Figure 3-6 and place one end truck on each runway.
- 3.2.2 Place the crane bridge on the end trucks, and secure it with bolts temporarily. If Harrington Hoists fabricated the bridge beam, the bridge beam and end truck frames are match marked. Refer to Figure 3-6.

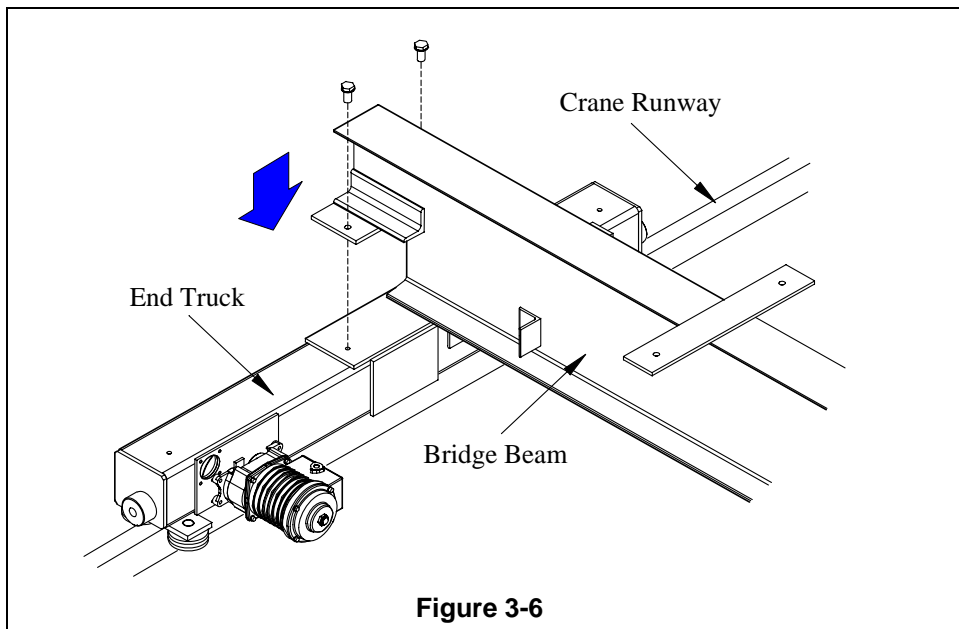

3.2.3 Refer to Figure 3-7 and check the following.

- a) Bridge beam centered on each end truck.
- b) Squareness of end truck frames to bridge beam; ($X = Y$).

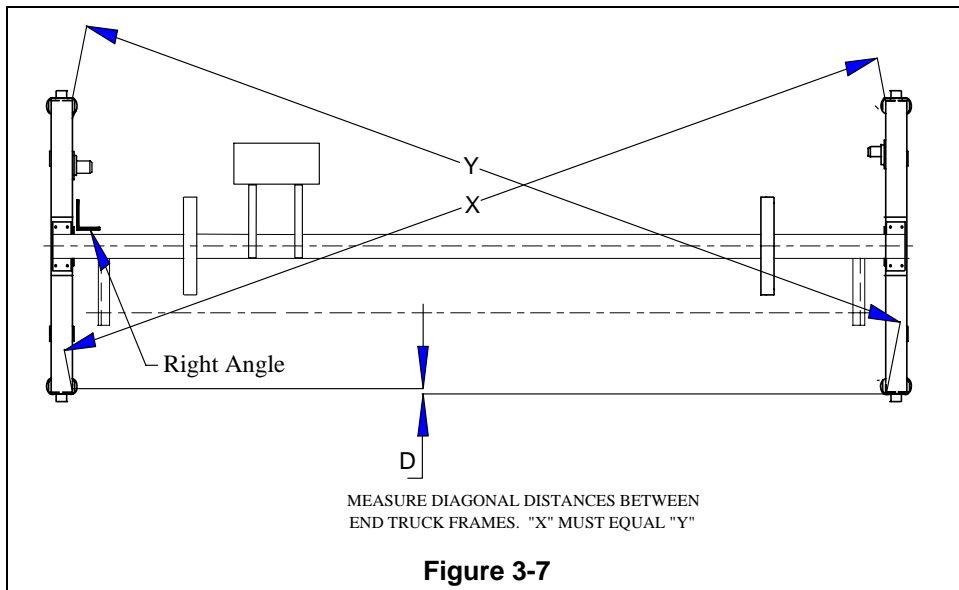

Make adjustments as necessary. Then securely tighten each fastened connection of the end truck frame to bridge beam. Refer to tightening torque values of Table 3-1.

- 3.2.4 Move the crane along the full length of the runway. Check for binding and guide roller clearance (normal clearance is 3/16 inch from each guide roller to runway rail edge).
- 3.2.5 Install braces on the crane bridge and the end trucks. Refer to Figure 3-8. Note: Figure 3-8 depicts a crane with two braces per end truck. Manual or Push crane systems require only one brace per end truck.

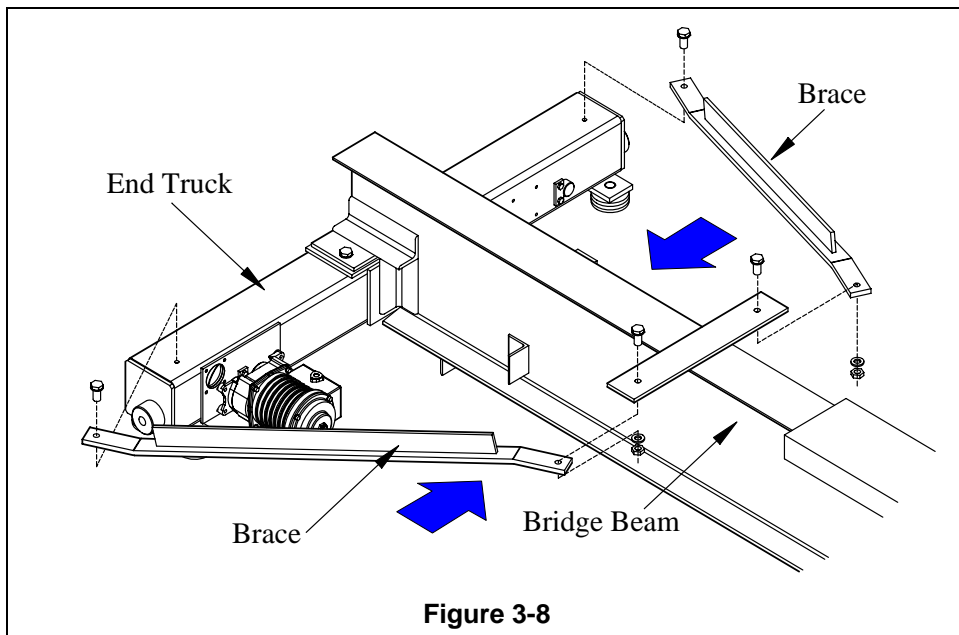

NOTICE Another way to install your crane system is to first assemble the crane on the floor beneath the runway/rails. Then lift the crane into position as shown in Figure 3-9.

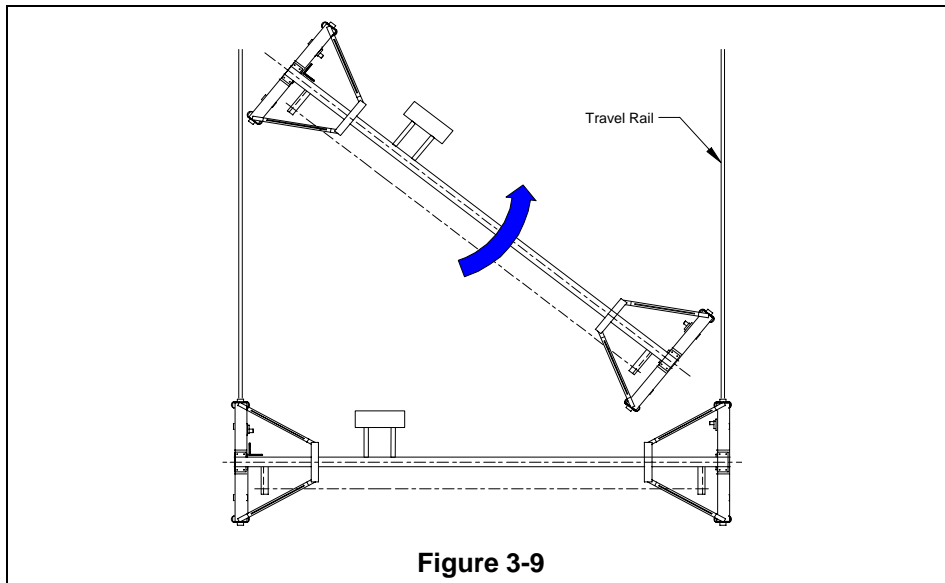

⚠ WARNING When installing the hoist and trolley on the bridge beam, refer to the installation instructions for your hoist and trolley.

3.3 Max-E-Lift End Trucks (for Double Girder Crane Systems)

3.3.1 Assemble and install the Max E Lift cranes using the appropriate information in section 3.1 or 3.2 based on whether your Max E Lift system is underhung or top running.

3.3.2 Refer to Figure 3-10 and verify the following:

- a) End Truck Alignment - verify $A = B$ and $X = Y$.

- b) Bridge Beams/Rails Alignment - Ensure that the bridge beams/rails conform to the manufacturer's requirements for the trolley/hoist (e.g. Parallelism, squareness, rail size, clearances, and gauge).
- c) Bridge Beam Coupling to the End Truck - Ensure that the bridge beams are located on the end trucks so that the center of gravity of the load is transferred to the middle of each end truck. Verify that $C1 = C2$.

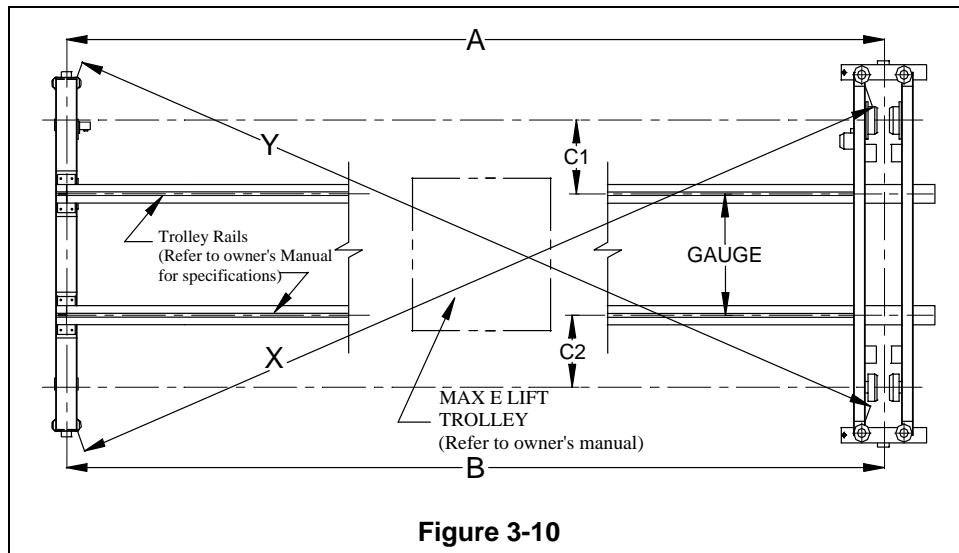

Make adjustments as necessary. Then securely tighten and double nut each fastened connection of the end truck frame to bridge beam. Refer to tightening torque values of Table 3-1.

- 3.3.3 Move the crane along the full length of the runway. Check for binding and guide roller clearance (normal clearance is 3/16 inch from each guide roller to runway beam flange edge or rail).

3.4 Drive Shafts for Geared End Trucks

- 3.4.1 General - The drive shaft configuration for your geared crane is shown in Figure 3-11 or Figure 3-12. Note that the number of Bearing Support Assemblies and Drive Shafts varies according to the span of the bridge crane system. Refer to Table 3-2.
 - a) Spans less than or equal to sixteen (16) feet - single piece drive shaft and no bearing support assembly.
 - b) Spans sixteen (16) to thirty-two (32) feet - two piece drive shaft and one bearing support assembly.
 - c) Spans greater than thirty-two (32) feet use multiple piece drive shafts with multiple Bearing Support Assemblies.

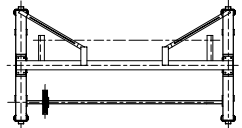
Table 3-2		
Span	Support Condition	Support Arms
Up to 16 feet		None

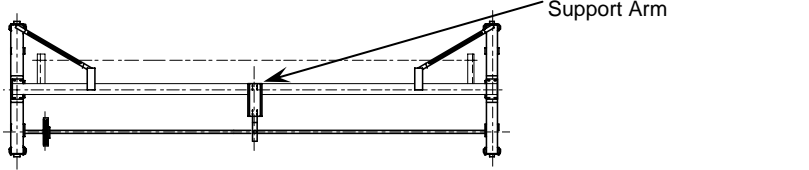
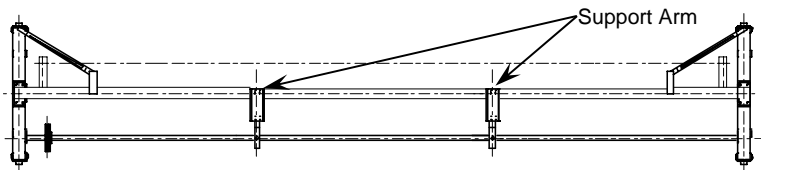
<p>16 to 32 feet</p>		<p>1 Point</p>
<p>32 or longer</p>		<p>2 or more Points</p>

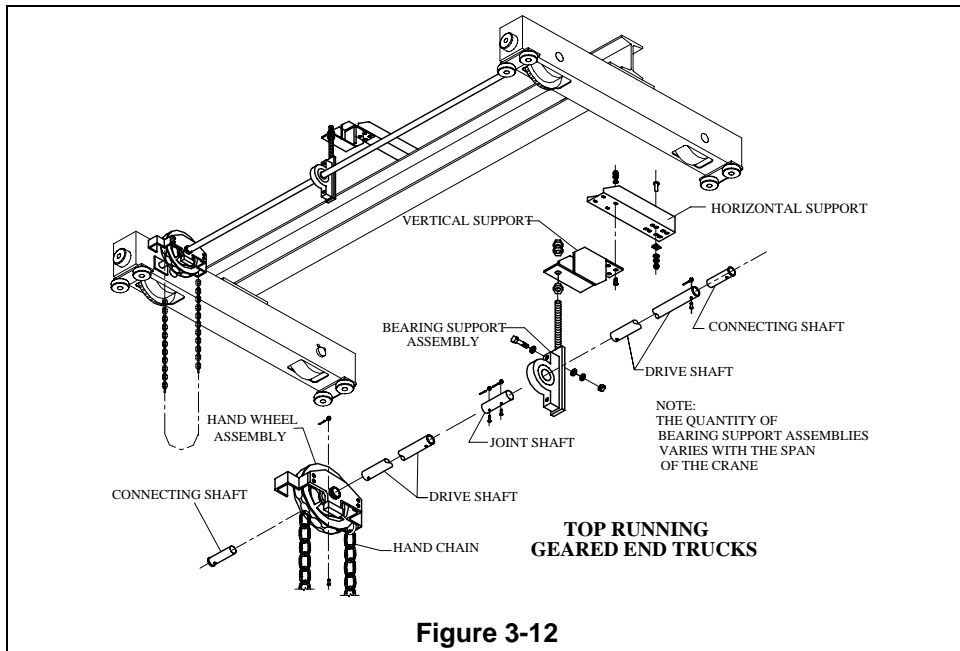
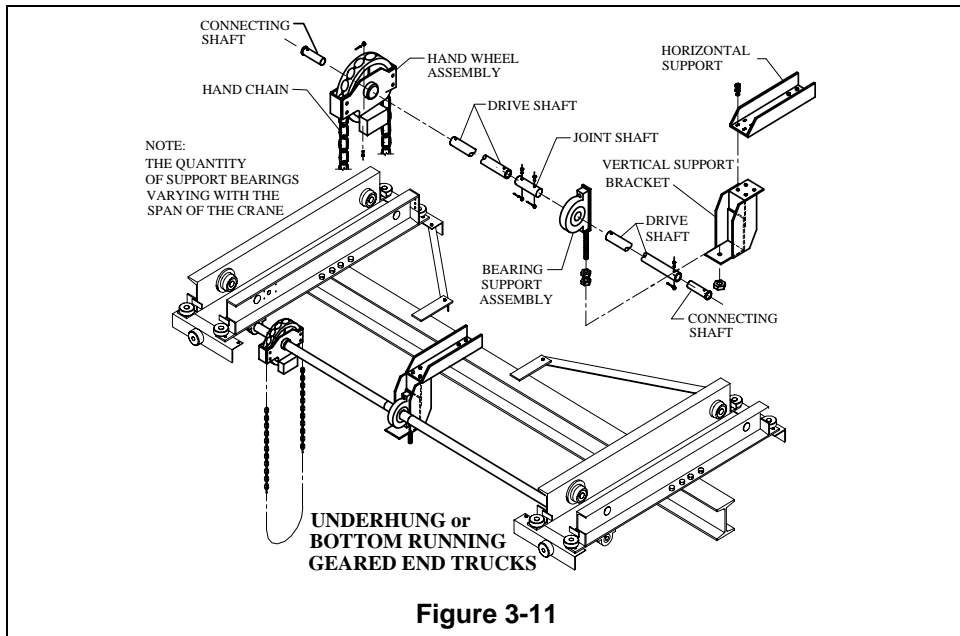

3.4.2 Single Piece Drive Shaft

- a) Install the Hand Wheel section of the Drive Shaft first.
 - (1) Slide the Hand Wheel over the Hand Wheel End of the Drive Shaft (the Hand Wheel end of the Drive Shaft is the end with a through-bolt hole two inches from the shaft end).
 - (2) Refer to Figure 3-13 or Figure 3-14 whichever applies and insert the connecting shafts into both ends of the Drive Shaft. Line up the three holes at the Hand Wheel end - hole in the hub of the Hand Wheel, hole in the Drive Shaft and the hole in the Connecting Shaft. Insert the long Bolt B and fasten using the nut and split pin.

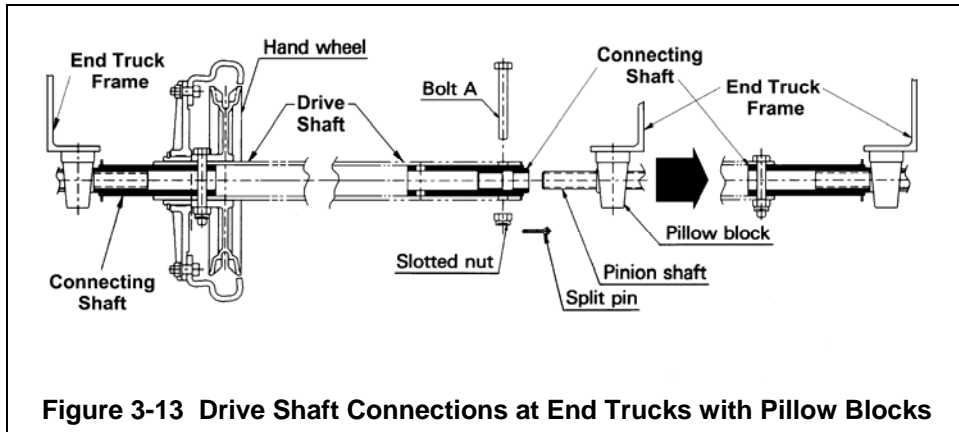

Figure 3-13 Drive Shaft Connections at End Trucks with Pillow Blocks

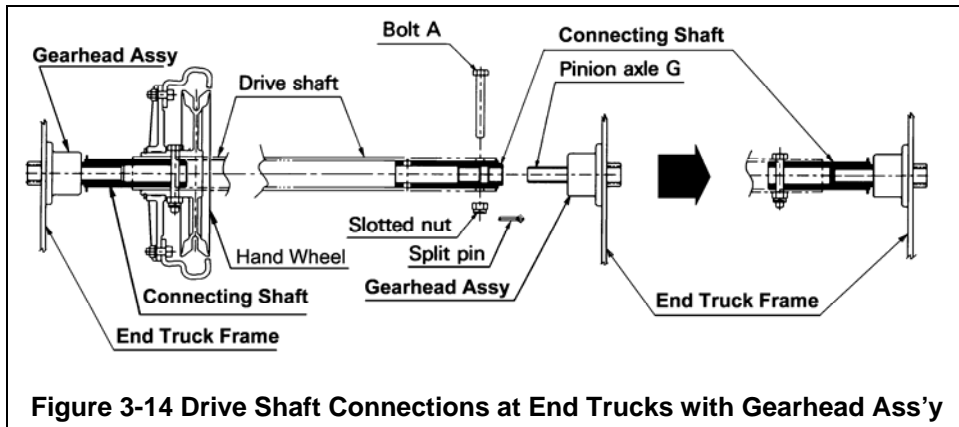

Figure 3-14 Drive Shaft Connections at End Trucks with Gearhead Ass'y

- (3) Next, hold the Hand Wheel end of the Drive Shaft adjacent to the splined Pinion Shaft/Axle. Slide the Connecting Shaft onto the Pinion Shaft/Axle. Refer to Figure 3-13 or Figure 3-14 whichever applies.
- (4) Last, line up the remaining end of the Drive Shaft with the splined Pinion Shaft/Axle on the other end truck and slide out the Connecting Shaft from the end of the Drive Shaft until the through-bolt holes line up between the Connecting Shaft and Drive Shaft. Fasten the Drive Shaft to the Connecting Shaft using Bolt A, the slotted nut and split pin.

3.4.3 Multiple Piece Drive Shaft

- a) Install the Bearing Support Assembly(s) onto the bridge beam. Refer to Figure 3-16 and note that for bridge beams with a flange width less than 5.5 inches use **Bolt Pattern A**. For bridge beams with a flange width of 5.5 inches or more use **Bolt Pattern B**.
- b) Install the Hand Wheel section of the Drive Shaft first.

- (1) Slide the Hand Wheel over the Hand Wheel End of the Drive Shaft (the Hand Wheel end of the Drive Shaft is the end with a through-bolt hole two inches from the shaft end).
- (2) Refer to Figure 3-13 or Figure 3-14 whichever applies and insert the Connecting Shaft into the Hand Wheel end of the Drive Shaft. Line up the three holes - hole in the hub of the Hand Wheel, hole in the Drive Shaft and the hole in the Connecting Shaft. Insert the long Bolt B and fasten using the nut and split pin.
- (3) Next, hold the Hand Wheel end of the Drive Shaft adjacent to the splined Pinion Shaft/Axle. Slide the Connecting Shaft onto the Pinion Shaft/Axle. Refer to Figure 3-13 or Figure 3-14 whichever applies.
- (4) Last, connect the remaining end of the Drive Shaft to the Joint Shaft in the Bearing Support Assembly. Refer to Figure 3-15. Hold the remaining end of the Drive Shaft adjacent to the Bearing Support Assembly. Slide the Joint Shaft through the opposite side of the Bearing Support Assembly and into the end of the Drive Shaft. Fasten the Drive Shaft to the Joint Shaft using Bolt A, slotted nut and split pin.

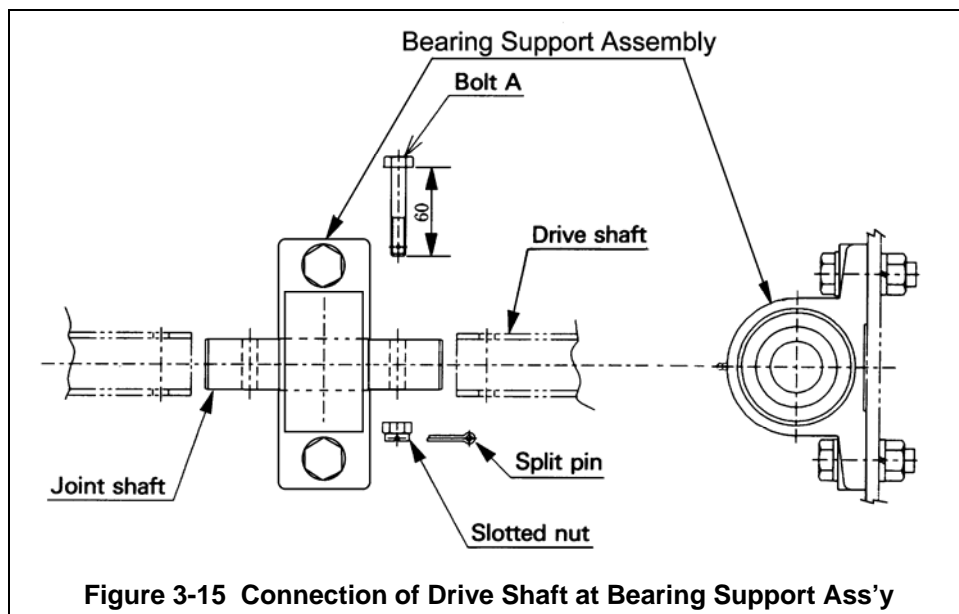

c) Middle Section(s) - (If required)

- (1) Slide the middle section Drive Shaft over the Joint Shaft previously installed. Refer to Figure 3-15.
- (2) Hold the remaining end of the Middle Drive Shaft adjacent to the next Bearing Support Assembly. Slide the Joint Shaft through the opposite side of the Bearing Support Assembly and into the end of the Drive Shaft.
- (3) Fasten the Drive Shaft to the Joint Shaft using Bolt A, slotted nut and split pin.

d) Install the last Drive Shaft Section to the End Truck.

- (1) Refer to Figure 3-13 or Figure 3-14 whichever applies and insert the Connecting Shaft into the end truck side of the Drive Shaft (the end truck "end" has the through-bolt hole two inches from the end of the Drive Shaft). Leave the Connecting Shaft fully inserted. Do not line up the through-bolt holes and do not fasten yet.
- (2) Slide the end truck side of the Drive Shaft (with connecting shaft fully inserted) onto the splined Pinion Shaft/Axle of the end truck. Refer to Figure 3-13 or Figure 3-14 whichever applies. Do not attempt to line up holes or fasten hardware.

- (3) Refer to Figure 3-15, and connect the remaining end of the Drive Shaft to the Joint Shaft previously installed at the Bearing Support Assembly and fasten.
- (4) Slide out the Connecting Shaft from the end of the Drive Shaft nearest the end truck until the through-bolt holes line up between the Connecting Shaft and Drive Shaft. Fasten the Drive Shaft to the Connecting Shaft using Bolt A, slotted nut and split pin.

NOTICE When installing the support arm on the crane bridge beam, note that the support arm installing pitch varies in each case, shown as in Figure 3-16, depending upon the width of the crane bridge beam flange.

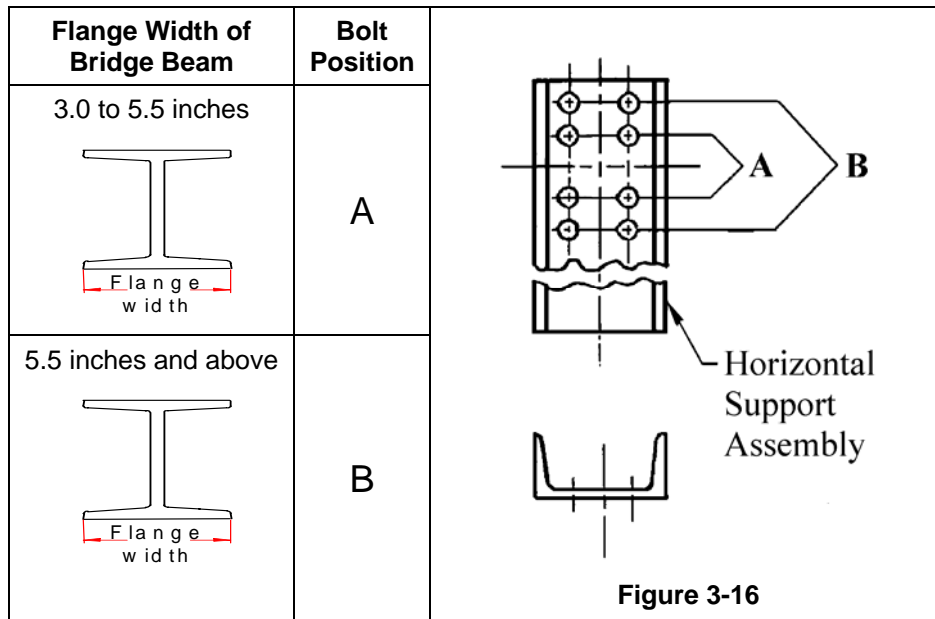

3.5 Crane Wiring (MOTORIZED ONLY)

⚠ WARNING HAZARDOUS ELECTRICAL POWER IS PRESENT IN THE END TRUCK MOTOR, IN THE SUPPLY OF ELECTRICAL POWER TO THE END TRUCK MOTOR, AND IN THE CONNECTIONS BETWEEN COMPONENTS.

Before performing ANY wiring installation or maintenance on the equipment, de-energize the electrical supply to the equipment, and lock and tag the supply device in the de-energized position. Refer to ANSI Z244.1, "Personnel Protection - Lockout/Tagout of Energy Sources."

Only trained and competent personnel should install, inspect, and maintain this equipment. ALWAYS turn off power source or breaker switch to prevent electric shock before beginning the wiring process

Install the crane system electrical wiring as shown on the **wiring diagram provided**.

3.6 Power Source

⚠ WARNING For crane systems requiring electrical power, ALWAYS provide crane runways with Class 3 grounding. Failure to provide an electrical ground in accordance with industry standards and local codes could result in electric shock. NEVER paint any wheels or wheel running surfaces in order to ground the crane properly.

NOTICE Provide electrical power to the crane and any powered components in accordance with applicable industry standards, local codes, and manufacturer's requirements. Sections 3.6.1 and 3.6.2 below provide general guidelines for typical configurations.

3.6.1 Power supply with enclosed conductors. (See Figure 3-17)

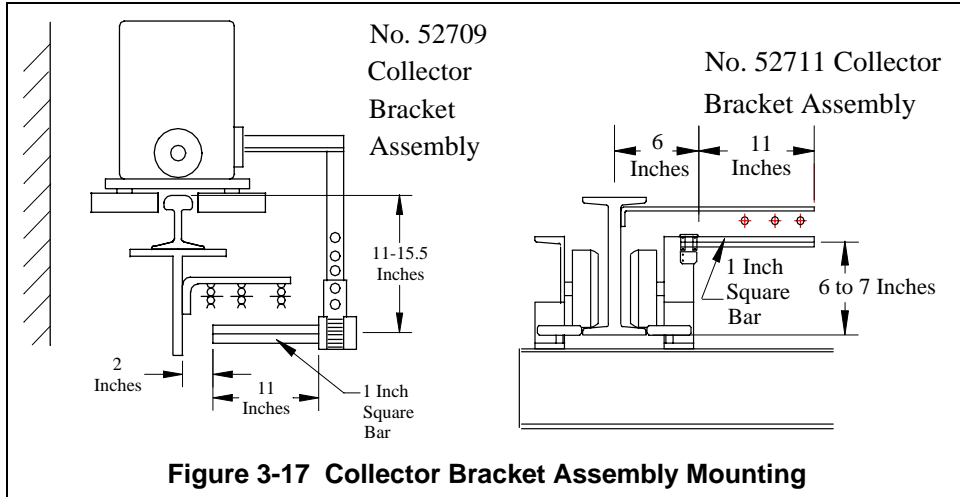

3.6.2 Power supply with festooned cable. (See Figure 3-18)

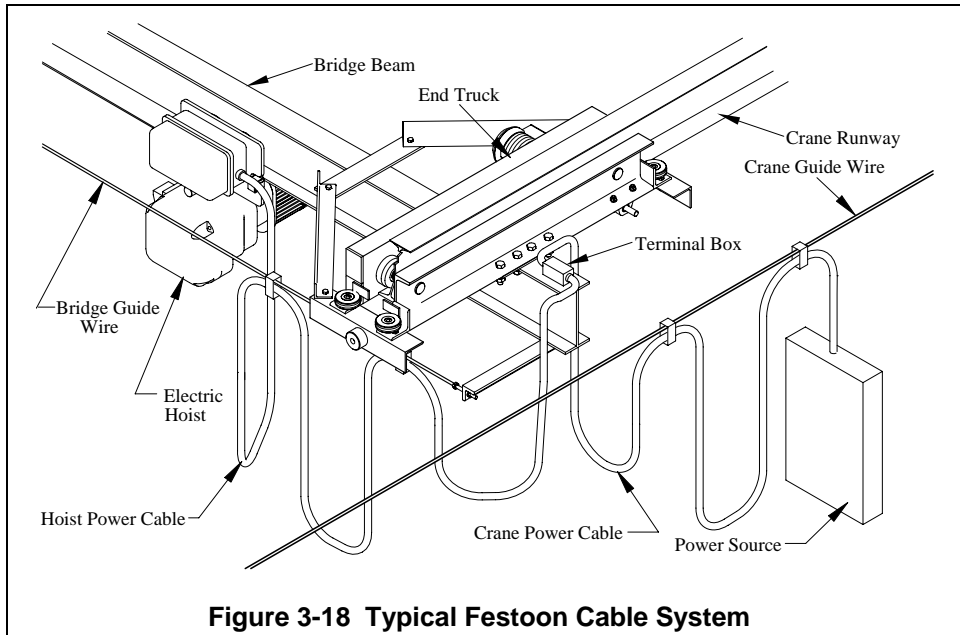

3.7 Testing

Prior to initial use the crane system (including all components) should be tested in accordance with the manufacturer's requirements and applicable ANSI standards. ANSI Standards that may apply for crane system applications include:

- ANSI B30.2 Overhead and Gantry Cranes
- ANSI B30.11 Monorails and Underhung Cranes
- ANSI B30.16 Overhead Hoists (Underhung)
- ANSI B30.17 Overhead and Gantry Cranes (Top Running Bridge, Single Girder, Underhung Hoist)

4.0 Operation

For systems using the equipment covered by this manual, the supplier and the owner of the system are responsible for providing information for use by operators for the safe operation of the system.

The Crane Manufacturer's Association of America publishes a Crane Operator's Manual that can be useful in properly operating your crane.

5.0 Inspection

5.1 General

5.1.1 The equipment covered by this owner's manual is most commonly used in the design and manufacture of overhead cranes and monorails. The inspection procedure herein is for these applications and is based on the applicable ANSI/ASME B30 volumes, namely:

- **ANSI B30.2** **Overhead and Gantry Cranes**
- **ANSI B30.11** **Monorails and Underhung Cranes**
- **ANSI B30.16** **Overhead Hoists (Underhung)**
- **ANSI B30.17** **Overhead and Gantry Cranes (Top Running Bridge, Single Girder, Underhung Hoist)**

NOTICE - for applications involving the equipment covered by this owner's manual which are not addressed by the aforementioned ANSI/ASME B30 volumes, the appropriate inspection should be determined and overseen by a qualified person.

5.1.2 The following definitions are from the ANSI/ASME B30 volumes listed in Section 5.1.1 above:

- **Designated Person** - a person selected or assigned as being competent to perform the specific duties to which he/she is assigned.
- **Qualified Person** - a person who, by possession of a recognized degree or certificate of professional standing, or who, by extensive knowledge, training, and experience, has successfully demonstrated the ability to solve or resolve problems relating to the subject matter and work.
- **Normal Service** - service which involves operating at less than a certain percentage of rated load and less than a specified frequency. Refer to the applicable ANSI/ASME B30 volume for the specific definition for your application.
- **Heavy Service** - that service which involves operation within the rated load limit which exceeds normal service.
- **Severe Service** - that service which involves normal or heavy service with abnormal operating conditions.

5.2 Inspection Classification

5.2.1 Initial Inspection - prior to initial use, all new, re-installed, altered, modified, or extensively repaired cranes shall be inspected by a designated person to verify compliance with the applicable provisions of this manual.

5.2.2 Inspection Intervals - the inspection procedure for cranes in regular service is divided into two general classifications based upon the intervals at which inspection should be performed. The intervals in turn are dependent upon the nature of the critical components of the crane and the degree of their exposure to wear, deterioration, or malfunction. The two general classifications are herein designated as FREQUENT and PERIODIC, with respective intervals between inspections as defined below.

5.2.3 FREQUENT Inspection - visual examinations by the operator or other designated personnel with intervals per the following criteria:

- Normal service - monthly
- Heavy service - weekly to monthly

- Severe service - daily to weekly
- Special or infrequent service - as recommended by a qualified person before and after each occurrence.

5.2.4 PERIODIC Inspection - visual inspection by a designated person with intervals per the following criteria:

- Normal service - yearly
- Heavy service - semiannually
- Severe service - quarterly
- Special or infrequent service - as recommended by a qualified person before the first such occurrence and as directed by the qualified person for any subsequent occurrences.

5.3 Frequent Inspection

5.3.1 Inspections should be made on a FREQUENT basis in accordance with Table 5-1, "Frequent Inspection." Included in these FREQUENT Inspections are observations made during operation for any defects or damage that might appear between Periodic Inspections. Evaluation and resolution of the results of FREQUENT Inspections shall be made by a designated person such that the crane is maintained in safe working condition.

Table 5-1 Frequent Inspection
All functional operating mechanisms for proper operation, proper adjustment, and unusual sounds.
End Truck braking system for proper operation
Hoist(s) in accordance with ANSI/ASME B30.16
Upper Limit Devices in accordance with ANSI/ASME B30.16
Hook(s) and hook latches in accordance with ANSI/ASME B30.10

5.4 Periodic Inspection

5.4.1 Inspections should be made on a PERIODIC basis in accordance with Table 5-2, "Periodic Inspection". Evaluation and resolution of the results of PERIODIC Inspections shall be made by a designated person such that the crane is maintained in safe working condition.

5.4.2 For inspections where load suspension parts of the hoist are disassembled, a load test per ANSI/ASME B30.16 must be performed on the hoist after it is re-assembled and prior to its return to service.

Table 5-2 Periodic Inspection
Requirements of frequent inspection.
Deformed, cracked or corroded members
Loose or missing bolts, nuts, pins, or rivets.
Worn, cracked, or distorted parts such as pins, bearings, wheels, shafts, gears, rollers, locking and clamping devices, bumpers, and stops.
Excessive wear of brake system parts
Deterioration of electrical components such as controllers, switches, contacts, pushbuttons.
Proper function of motion limit devices that interrupt power or cause a warning to be activated.
Function, instruction, and warning labels for legibility and replacement.

5.5 Occasionally Used Cranes

5.5.1 Cranes that are used infrequently shall be inspected as follows prior to placing in service:

- Cranes Idle More Than 1 Month, Less Than 1 Year: Inspect per FREQUENT Inspection criteria of Section 5.3 above.
- Cranes Idle More Than 1 Year: Inspect per PERIODIC Inspection criteria of Section 5.4 above.

5.6 Inspection Records

Dated inspection reports and records should be maintained for PERIODIC inspections. These records should be stored where they are available to personnel involved with the inspection, maintenance, or operation of the crane.

5.7 Inspection Methods and Criteria

5.7.1 This section covers the inspection of specific items. In accordance with ANSI/ASME B30 volumes listed in paragraph 5.1 above, these inspections are not intended to involve disassembly of the crane. Rather, disassembly for further inspection would be required if frequent or periodic inspection results so indicate. Such disassembly and further inspection should only be performed by a qualified person trained in the disassembly and re-assembly of the crane.

Table 5-3 Inspections Methods and Criteria

Crane Component	Item	Method	Criteria	Action
Crane Electric Parts	1. Power supply (For cable power supply system)			
	Guide (messenger) wire tension	Check visually.	The wire must be sufficiently tight to minimize sag.	Tighten when necessary.
	Cable hanger installation and mobility	Check visually.	The cable must be hung from cable hangers at even intervals. The cable must be hung from the cable hangers so that it does not twist.	Replace hangers when necessary.
	Cable length	Check visually.	The cable must be 10% longer than the crane's maximum travel distance.	Replace cable with a longer one when necessary.
	2. Ground protection	Verify Non-Current Carrying parts are grounded.	Non-Current Carrying Parts must be grounded and must not exceed 100 Ohms resistance to ground. Travel surfaces must be kept clean and free of insulating materials such as paint, oil, or grease.	Ground parts to conform with applicable standards and regulations. Remove any insulating materials.
3. Insulation	Use Insulation Resistance Meter to check wiring integrity.	Insulation resistance must be 0.5 Meg Ohms or more.	Replace wires/cables that have defective insulation.	
Travel Rail/ Runway	4. Travel Rail / Runway			
	Looseness in fasteners	Check tightness or torque.	Fasteners must be sufficiently tight.	Tighten when necessary.
	Oil, grease or paint on traveling surfaces	Check visually	The traveling surfaces must be free of oil, grease, or paint.	Clean where necessary.
	Rails/Runways Dimensions	Measure	Dimensions to be in accordance with CMAA criteria given in Table 2-1 of this owner's manual.	Adjust as necessary to meet the criteria.
Girder (Bridge Beam)	5. Girder (Bridge Beam)			
	Bridge Beam	Check visually and measure.	The beam must not be deformed or damaged.	Repair or replace parts as necessary.
	Welded parts	Check visually and use NDT if necessary.	Welds to be in accordance with CMAA criteria.	Repair as necessary.
	Bridge Beam	Check visually and measure.	The travel surface must not be worn excessively.	Replace.
	Looseness in fasteners	Check tightness or torque.	Fasteners must be sufficiently tight.	Tighten where necessary.
	Deflection	Measure under a rated load at mid span	Deflection must be within 1/600 or less of the span.	Repair or replace, or lower the rated capacity.

Table 5-3 Inspections Methods and Criteria

Crane Component	Item	Method	Criteria	Action
End Truck	6. End truck			
	Track wheel (Underhung End Trucks)	Measure.	Diameter must not be less than "when worn" value in Table 5-4. And, for geared and motorized end trucks the diameter of the drive wheels on the left end truck must not be different from the diameter of the drive wheels on the right end truck by more than the value in Table 5-5. Flange dimension (for geared and motorized end trucks only) must not be less than "when worn" in Table 5-4.	Replace.
	Track Wheel (Top Running End Trucks)	Measure	Diameter must not be less than "when worn" value in Table 5-4. And for geared and motorized end trucks the diameter of the drive wheel on the left end truck must not be different from the diameter of the drive wheel on the right end truck by more than the value in Table 5-5.	Replace.
	Track Wheel Gear Teeth (geared and motorized end trucks only)	Visual	Teeth should not be cracked, damaged, or excessively worn.	Replace.
	Missing or incorrectly positioned snap rings	Check visually	No snap rings must be missing or out of position.	Replace or re-install as necessary.
	Guide roller wear	Measure.	Roller diameter must not be less than the "when worn" value in Table 5-6.	Replace.
	Lubrication	Check visually.	The track wheel teeth and teeth of the pinion L must be sufficiently lubed.	Grease where necessary.
	Bolts/fasteners	Check tightness or torque.	Bolts and fasteners must be sufficiently tight.	Tighten where necessary.
Gear Motor	7. Gear Motor			
	Bolts	Check tightness or torque.	Bolts should be sufficiently tight.	Tighten where necessary.
	Outer appearance	Check visually.	No cracks or other damage should be detected	Replace parts where necessary.
	Damage to bearings	Try turning by hand.	Bearings should turn smoothly.	Replace parts where necessary.
	Braking	Start and stop the crane.	The crane must come to a smooth stop within 10% of its traveling speed when the brakes are applied.	Adjust the left and right motor brakes. Refer to Section 7. Replace parts where necessary.
	Lubrication	Overhaul and check visually. Refer to Section 7	Parts must be sufficiently lubricated. Lubricated parts must not be overly dirty or contaminated with foreign matter.	Grease or degrease where necessary. Replace parts where necessary.

Table 5-4 End Truck Wheel Dimensional Data					
Underhung Crane					
	D	Std.	110 mm	125 mm	140 mm
			4.33 inch	4.92 inch	5.51 inch
	Discard		105 mm	119 mm	133 mm
			4.13 inch	4.69 inch	5.24 inch
t	Std.	18 mm	18.5 mm	19 mm	
		0.71 inch	0.73 inch	0.75 inch	
Discard		13 mm	13.5 mm	14.5 mm	
		0.51 inch	0.53 inch	0.57 inch	
Top Running Crane					
	D	Std.	95 mm	155 mm	
			3.74 inch	6.10 inch	
	Discard		90 mm	147 mm	
			3.54 inch	5.79 inch	
D	Std.	210 mm	250 mm		
		8.27 inch	9.84 inch		
Discard		200 mm	238 mm		
		7.87 inch	9.37 inch		

Table 5-5 Allowable Diameter Difference for Drive Wheels			
Underhung Crane			
Wheel Diameter	110 mm 4.33 inch	125 mm 4.92 inch	140 mm 5.51 inch
Allowed Difference	1.1 mm 0.04 inch	1.2 mm 0.05 inch	1.4 mm 0.06 inch
Top Running Crane			
Wheel Diameter	95 mm 3.74 inch	155 mm 6.10 inch	
Allowed Difference	1.0 mm 0.04 inch	1.5 mm 0.05 inch	
Wheel Diameter	210 mm 8.27 inch	250 mm 9.84 inch	
Allowed Difference	2.1 mm 0.08 inch	2.5 mm 0.10 inch	

Table 5-6 Guide Roller Wear Dimensional Data			
Std.	90 mm 3.54 inch	125 mm 4.92 inch	
When worn	82 mm 3.23 inch	117 mm 4.61 inch	

6.0 Lubrication

Lubricants to be used for the maintenance of your end trucks are listed in the following table.

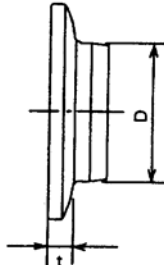
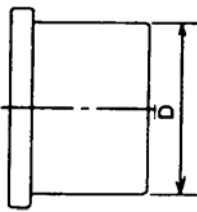
Location	Manufacturer and type	Amount			
Reduction gear	Shell/Albania Grease 2	kW	0.25	0.4	0.75 & 1.5
		grams (ounces)	50 (1.8)	60 (2.1)	150 (5.3)
Brake disk spline sliding parts of armature	Sumitomo Kogyou/Morispeed Grease No. 2	Light coat			

7.0 Maintenance and Handling

7.1 General

Components of your End Trucks that require maintenance are as follows:

For Motorized End Trucks:

- Reduction Gearing in the Gear motor
- Brake Assembly in the Gear motor
- End Truck Drive Gears

For Geared End Trucks:

- End Truck Drive Gears

For Manual End Trucks:

- No items that require maintenance

7.2 Gear Motor - Reduction Gears

- a) The reduction gearing in the gear motor should be cleaned and lubricated at least once per year for normal usage. Clean and lubricate the reduction gear assembly more frequently for heavier usage or severe conditions.
- b) To clean and lubricate the reduction gearing in the gear motor refer to Figure 7-1 and disassemble as follows:
 - (1) Detach the socket bolts 313.
 - (2) Disassemble gearbox A 303 from gearbox B 401.
 - (3) Remove gearbox packing 310.
 - (4) Clean components and re-lubricate using an approved lubricant from Table 6-1 in Section 6.
- c) Reassemble as follows:
 - (1) Reassemble in reverse order of the disassembly procedure.
 - (2) Coat the threaded portion of the socket bolts 313 with, Loc-Tite, or similar glue.
 - (3) Once assembled, free the brake and ensure that the gears are meshed properly by turning the pinion by hand.

7.3 Gear Motor - Brake

- b) The brake in the gear motor should be cleaned, parts lubricated and adjusted at least once per year for normal usage. Clean and lubricate the reduction gear assembly more frequently for heavier usage or severe conditions. **DO NOT** disassemble the motor itself.
- c) To clean, lubricate and adjust the brake in the gear motor refer to Figure 7-1 and disassemble as follows:
 - (1) Remove the electromagnetic coil assembly 5610 by detaching the socket bolts 607.
 - (2) As the electromagnetic coil assembly 5610 is wired to the terminal box of the motor, be careful when handling the wiring.
 - (3) Remove the spring holder 605, brake spring 606, armature 513 and brake disk 512.
 - (4) Lightly grease the spline of the brake disk 512 and sliding parts of the armature 513 with MORISPEED grease No. 2 or similar.

- (5) Inspect the brake disc for wear and replace if necessary. Do not allow grease or oil on the brake disc surface.
- d) Reassemble as follows:
- (1) During re-assembly be careful not to pinch the lead wires when assembling the electromagnetic coil 5610.
 - (2) Assemble the motor with the brake disc 512 and armature 513. Ensure that the brake disk is properly oriented and not backwards when installing. (Flat side facing AWAY from motor)
 - (3) Insert the Spring Holder 605 and the Brake Spring 606 into the center recess of the Electromagnetic Coil Assembly 5610.
 - (4) Re-assemble the Electromagnetic Coil Assembly 5610 onto the motor ensuring that the Spring Holder 605 and the Brake Spring 606 remain inserted properly. Fasten using Socket Bolts 607.

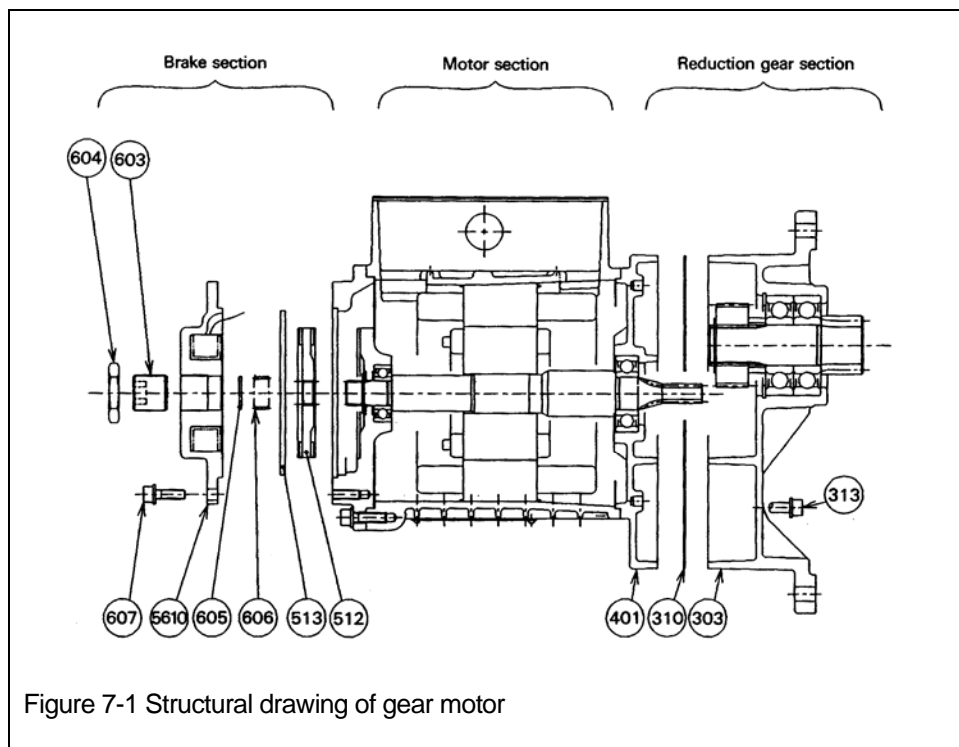

Figure 7-1 Structural drawing of gear motor

Table 7-1 Part List for Gear Motor			
Part No.	Part name	Part No.	Part name
303	Gear box A	5610	Electromagnetic coil assembly
313	Socket bolt	603	Adjusting bolt
401	Gear box B	604	Lock nut
512	Brake disk	605	Spring holder
513	Armature	606	Brake spring
310	Gear box packing	607	Socket bolt

7.4 Brake Adjustment

With this gear motor, brake torque can be adjusted within the range of 0 to 50% against the motor rated torque, with the adjusting bolt. Readjust the brake torque when the braking surface of the disk is worn and the braking force decreases.

⚠ WARNING Always set the brake torque for the left and right end trucks at the same value.

a) To adjust brake torque refer to Figure 7-2, Table 7-2, and Table 7-3:

- (1) Loosen the lock nut 604.
- (2) Brake torque is set by changing the height H of the adjusting bolt 603. The setting range is within 0 to 50% of the motor's rated torque.
- (3) Tighten the lock nut 604. Do not to allow adjusting bolt 603 to move while tightening the lock nut.

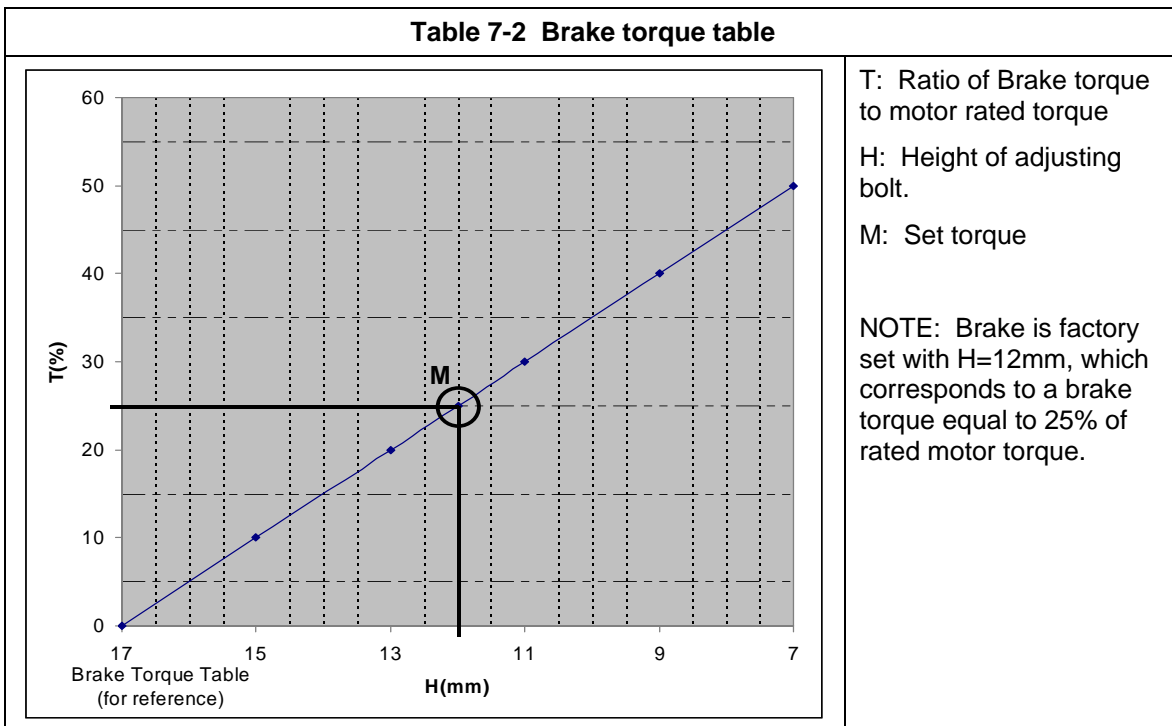
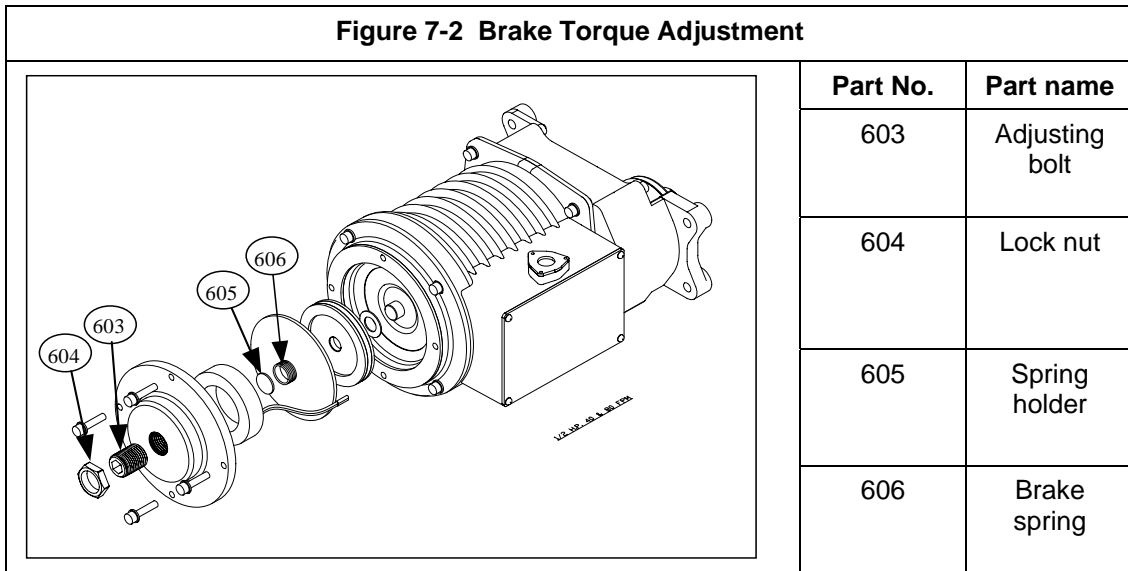

Table 7-3 Metric to Imperial Conversion Reference for "H" Values					
17 mm	15 mm	13 mm	11 mm	9 mm	7 mm
0.67"	0.59"	0.51"	0.43"	0.35"	0.28"

7.5 Storage

- 7.5.1 Whenever the end trucks are to be placed into storage, place extra grease onto all exposed unpainted parts such as the wheels, gears, collars and splines. Make certain that no debris, dirt or moisture is allowed to accumulate on the end truck during preparations for storage.

The storage location should be clean and dry.

7.6 Outdoor Installations

- 7.6.1 For crane system installations that are outdoors, the end trucks should be protected from the weather when not in use.
- 7.6.2 In order to prevent internal corrosion from occurring, the end trucks may require lubrication more often than once or twice per year.

8.0 Troubleshooting

WARNING

HAZARDOUS VOLTAGES ARE PRESENT IN THE MOTORIZED END TRUCK AND IN CONNECTIONS BETWEEN COMPONENTS.

Before performing ANY maintenance on the equipment, de-energize the electrical supply to the equipment, and lock and tag the supply device in the de-energized position. Refer to ANSI Z244.1, "Personnel Protection - Lockout/Tagout of Energy Sources."

Only Trained and competent personnel should inspect and repair this equipment.

Table 8-1 Troubleshooting Guide

Trouble	Cause	Remedy
The crane does not move smoothly.	<p>The end truck is not set at a right angle to the bridge beam or the left and right end trucks are not parallel to one another.</p> <p>Track wheels are unevenly worn.</p> <p>Runway span out of tolerance.</p> <p>Brake force is unbalanced between the left and right brakes.</p> <p>A gap has formed between the guide rollers and the runway rail. May be due to wear in the guide roller.</p>	<p>Set the end trucks at a right angle to the bridge beam, and parallel with one another.</p> <p>Replace the wheels where necessary.</p> <p>Adjust runways where necessary. See Table 2-1.</p> <p>Adjust the left and right brakes.</p> <p>Replace the guide rollers where necessary.</p>
Bumpers on the left and right end truck do not contact the end stops at the same time.	The crane is not square. May be due to bolts coupling the end truck to the bridge beam are loose.	Adjust so that contact is made at the same time, and tighten bolts where necessary.
The motor fails to turn and makes a humming sound.	<p>The brake is not releasing.</p> <p>Electronic soft start's torque volume is adjusted too low.</p> <p>The electronic soft start is damaged.</p>	<p>Check the brakes and wiring to brakes.</p> <p>Increase torque volume.</p> <p>Repair or replace the soft start when necessary.</p>
The motor gets extremely hot.	<p>The motor is running on a single-phase condition.</p> <p>Power supply voltage has dropped.</p> <p>The brake circuit is disconnected.</p> <p>The rectifier is damaged.</p>	<p>Repair wiring to restore 3-phase operation.</p> <p>Ensure power supply is at proper voltage.</p> <p>Repair wiring to restore brake circuit.</p> <p>Replace the rectifier.</p>

Table 8-1 Troubleshooting Guide

Trouble	Cause	Remedy
Electrical shock	The crane is not properly grounded. The travel surface on the bridge beam or runway is coated with oil, grease, paint, or corrosion. Water or foreign matter has penetrated the electric parts.	Ground parts where necessary. Remove foreign material from travel surface or add ground conductor for hoist power. Dry parts and remove any foreign matter where necessary.
The crane accelerates too slowly.	The electronic soft start's torque volume is adjusted too low. The electronic soft start's timer is adjusted too low.	Increase torque volume. Decrease the timer setting.
The crane accelerates too rapidly.	The electronic soft start's timer is adjusted too low.	Increase the timer setting.
Stopping distance is too long.	Brake torque is too low. Brake parts are worn.	Adjust the brake torque to a higher setting. Replace parts where necessary.
Stopping distance is too short.	Brake torque is too high.	Adjust the brake torque to a lower setting.

9.0 Warranty

Warranty explanation and terms

All products sold by Harrington Hoists, Inc. are warranted to be free from defects in material and workmanship from date of shipment by Harrington for the following periods:

Manual Hoists & Trolleys - 2 years

Air and Electric Powered Hoists, Trolleys, and Crane Components - 1 year

Spare / Replacement Parts - 1 year

The product must be used in accordance with manufacturer's recommendations and must not have been subject to abuse, lack of maintenance, misuse, negligence, or unauthorized repairs or alterations.

Should any defect in material or workmanship occur during the above time period in any product, as determined by Harrington Hoist's inspection of the product, Harrington Hoists, Inc. agrees, at its discretion, either to replace (not including installation) or repair the part or product free of charge and deliver said item F.O.B. Harrington Hoists, Inc. place of business to customer. Customer must obtain a Return Goods Authorization as directed by Harrington or Harrington's published repair center prior to shipping product for warranty evaluation. An explanation of the complaint must accompany the product. Product must be returned freight prepaid. Upon repair, the product will be covered for the remainder of the original warranty period. If it is determined there is no defect, or that the defect resulted from causes not within the scope of Harrington's warranty, the customer will be responsible for the costs of returning the product.

Harrington Hoists, Inc. disclaims any and all other warranties of any kind expressed or implied as to the product's merchantability or fitness for a particular application. Harrington will not be liable for death, injuries to persons or property or for incidental, contingent, special or consequential damages, loss or expense arising in connection with the use or inability whatever, regardless of whether damage, loss or expense results from any act or failure to act by Harrington, whether negligent or willful, or from any other reason.

This page intentionally left blank.

10.0 Replacement Parts Guide

Table of Contents

Ordering Parts	pg. 53
Underhung End Trucks	pg. 54
Top Running End Trucks	pg. 58
Hand Wheel Assy & Drive Shaft	pg. 64
Electric Gear Motors	pg. 68
Gear Head Assembly	pg. 76

Ordering Parts

1. When ordering Parts, please provide the End Truck's model number located on the End Truck's nameplate (see fig. below).
2. To aid in ordering Parts and Product Support, record the End Truck's model and serial number in the space provided on the cover of this manual.

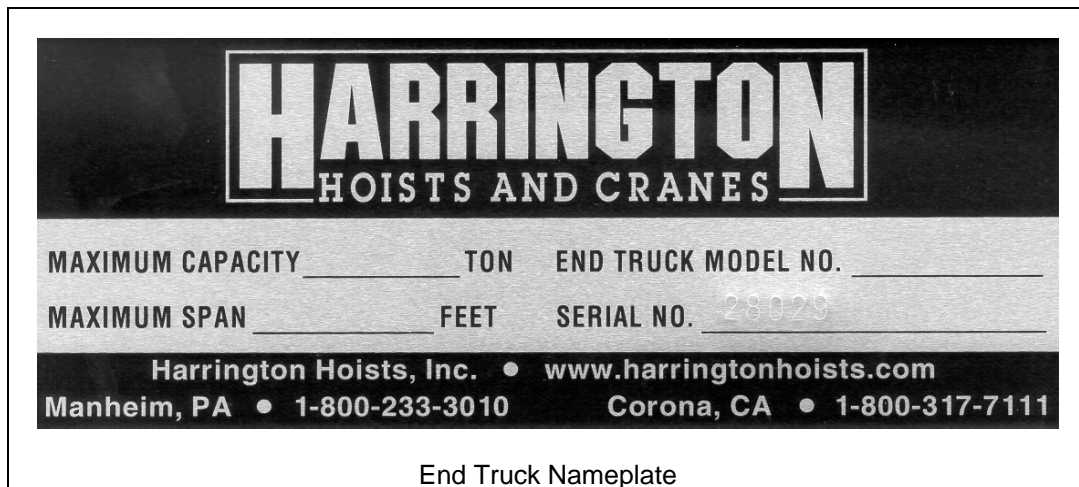

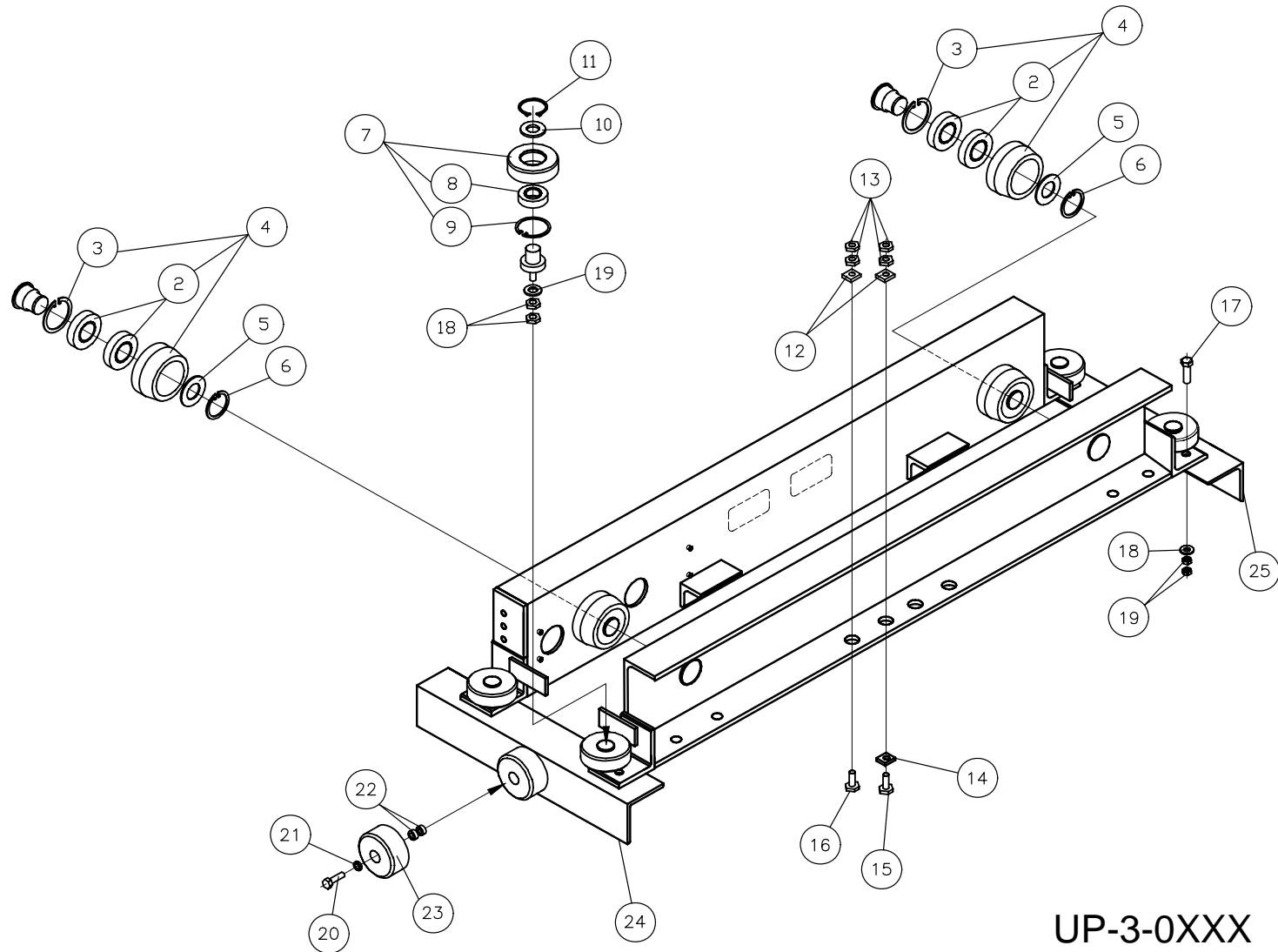

Figure 10-1 Underhung Push End Truck Parts View

Applicable End Truck Models - UP-3-0135 to 0535

Figure No.	Part Name	Quantity Per Pair	Applicable End Truck		
			UP-3-0235 to 0245	UP-3-0335	UP-3-0535
4	Track Wheel "B" Assembly	8	62345-01	62345-02	62345-03
2	Ball Bearing	16	90006-06 (6206-ZZ)	90005-07 (6007-ZZ)	90005-08 (6008-ZZ)
3	Snap Ring	8	90472-62	90472-62	90472-68
5	Washer	8	62324-01	62324-02	62324-03
6	Snap Ring	8	90471-30	90471-35	90471-40
7	Guide Roller Assembly	8	N6QO3101108		
8	Ball Bearing	8	90006-05 (6205-ZZ)		
9	Snap Ring	8	90472-52		
10	Washer	8	62324-04		
11	Snap Ring	8	90471-25		
12	Tapered Washer	16	90434-18 (M16x5°)		90434-22 (M20x5°)
13	Nut	32	90934-39 (M16x2.0)		90934-45 (M20x2.5)
14	Tapered Washer	8	90435-18 (M16x9°)		90435-22 (M20x9°)
15	Bolt	8	90933-124 (M16x90)		90933-168 (M20x100)
16	Bolt	8	90931-92 (M16x65)		90933-135 (M20x75)
17	Bolt	8	90931-46 (M12x45)		
18	Washer	8	90125-15 (M12)		
19	Nut	16	90934-33 (M12x1.75)		
20	Bolt	4	90931-01 (M8x35)		
21	Washer	4	90125-14 (M10)		
22	Nut	8	90934-24 (M8x1.25)		
23	Buffer	4	N6QL210207		
24	End Bracket "A"	2	62346-01		
25	End Bracket "B"	2	62346-02		

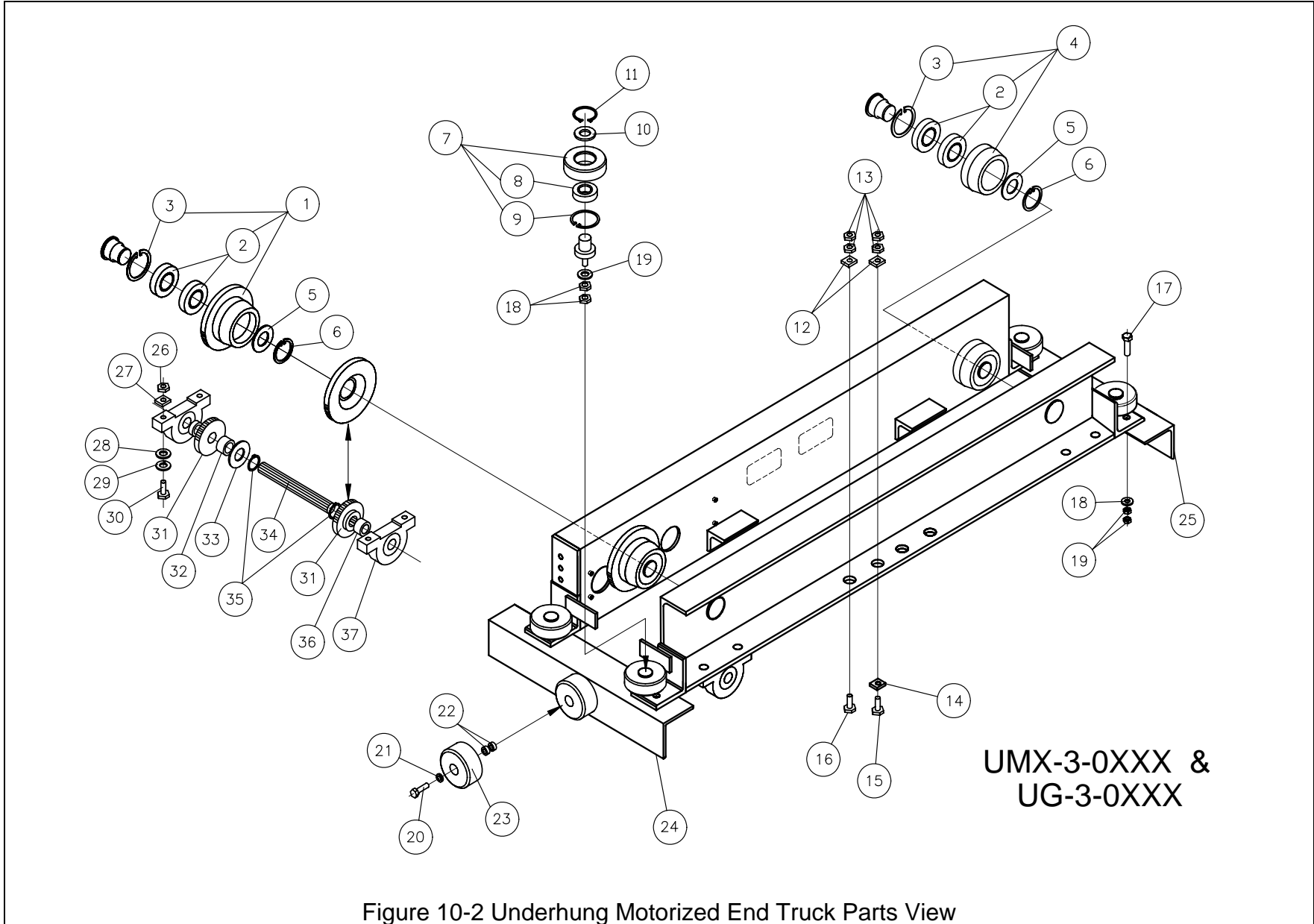

Figure 10-2 Underhung Motorized End Truck Parts View

Applicable End Truck Models - UMX-3-0235 to 0550 & UG-3-0235 to 0550

Figure No.	Part Name	Quantity Per Pair	Applicable End Truck		
			UML/S/H/D-3-0235 to 0250 UG030-0235 to 0245	UML/S/H/D-3-0335 to 0350 UG-3-0335 to 0345	UML/S/H/D-3-0535 to 0550 UG-3-0535 to 0545
1	Track Wheel "A" Assembly	4	N6QL5101101	N6QL5201101	N6QL5301101
2	Ball Bearing	16	90006-06 (6206-ZZ)	90005-07 (6007-ZZ)	90005-08 (6008-ZZ)
3	Snap Ring	8	90472-62	90472-62	90472-68
4	Track Wheel "B" Assembly	4	62345-01	62345-02	62345-03
5	Washer	8	62324-01	62324-02	62324-03
6	Snap Ring	8	90471-30	90471-35	90471-40
7	Guide Roller Assembly	8	N6QO3101108		
8	Ball Bearing	8	90006-05 (6205-ZZ)		
9	Snap Ring	8	90472-52		
10	Washer	8	62324-04		
11	Snap Ring	8	90471-25		
12	Tapered Washer	16	90434-18 (M16x5°)		90434-22 (M10x5°)
13	Nut	32	90934-39 (M16x2.0)		90934-45 (M20x2.5)
14	Tapered Washer	8	90435-18 (M16x9°)		90435-22 (M20x9°)
15	Bolt	8	90933-124 (M16x90)		90933-168 (M20x100)
16	Bolt	8	90931-92 (M16x65)		90933-135 (M20x75)
17	Bolt	8	90931-46 (M12x45)		
18	Washer	8	90125-15 (M12)		
19	Nut	16	90934-33 (M12x1.75)		
20	Bolt	4	90931-01 (M8x35)		
21	Washer	4	90125-14 (M10)		
22	Nut	8	90934-24 (M8x1.25)		
23	Buffer	4	N6QL210207		
24	End Bracket "A"	2	62346-02		
25	End Bracket "B"	2	62346-01		
26	Nut	8	90934-27 (M10x1.5)		
27	Tapered Washer	8	90434-11 (M10x5°)		
28	Washer	8	90125-14 (M10)		
29	Spring Washer	8	90127-12 (M10)		
30	Bolt	8	90933-54 (M10x50)		
31	Pinion L	4	N6QL210113		N6QL520113
32	Collar "A"	6	N6QL210115		
33	Washer	10	90125-19 (M20)		
34	Pinion Axle L	2	N6QL210114		
35	Snap Ring	4	90471-20		
36	Collar "B"	4	N6QL210209		
37	Pillow Block	4	N6QL210116		

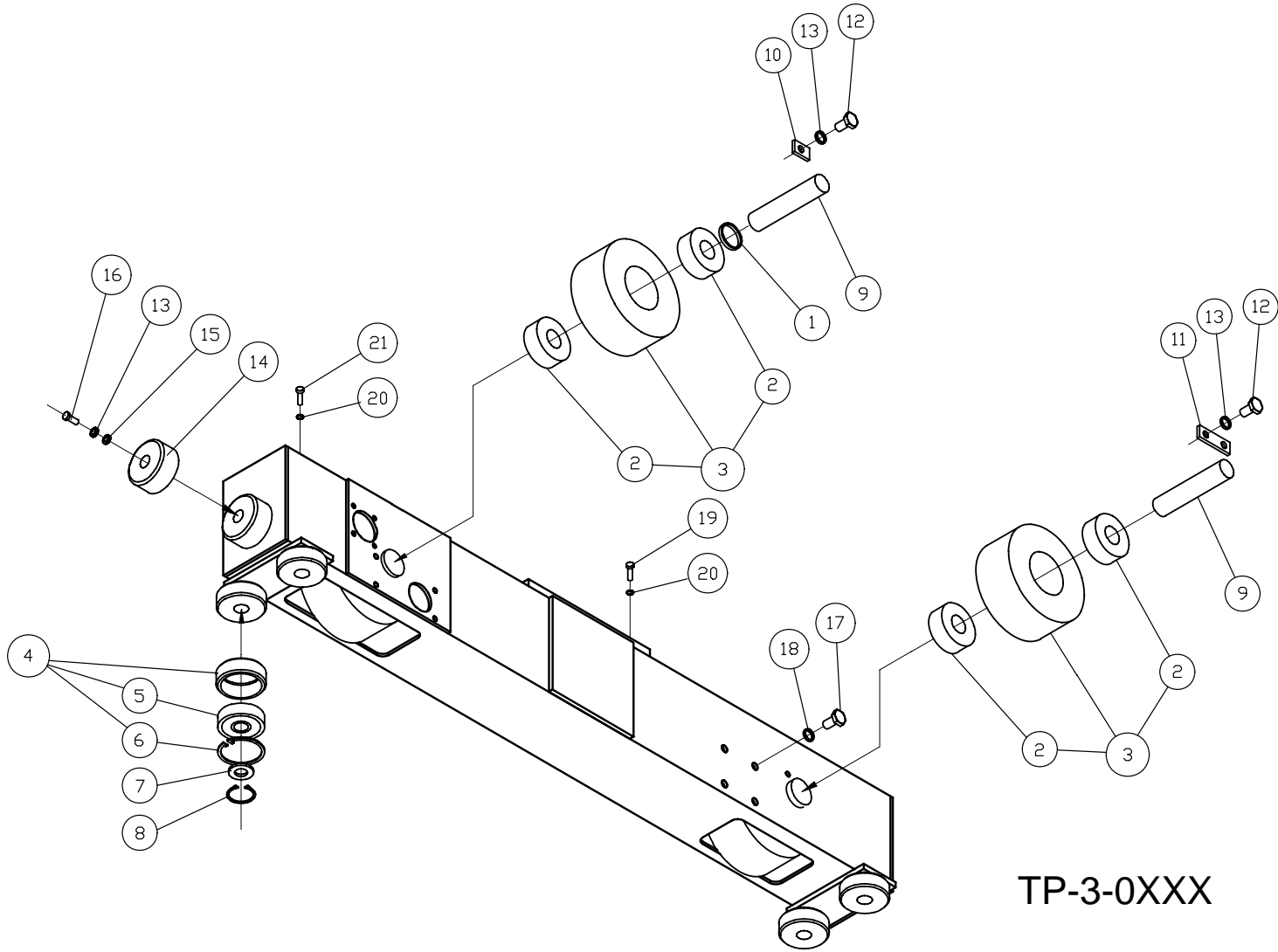
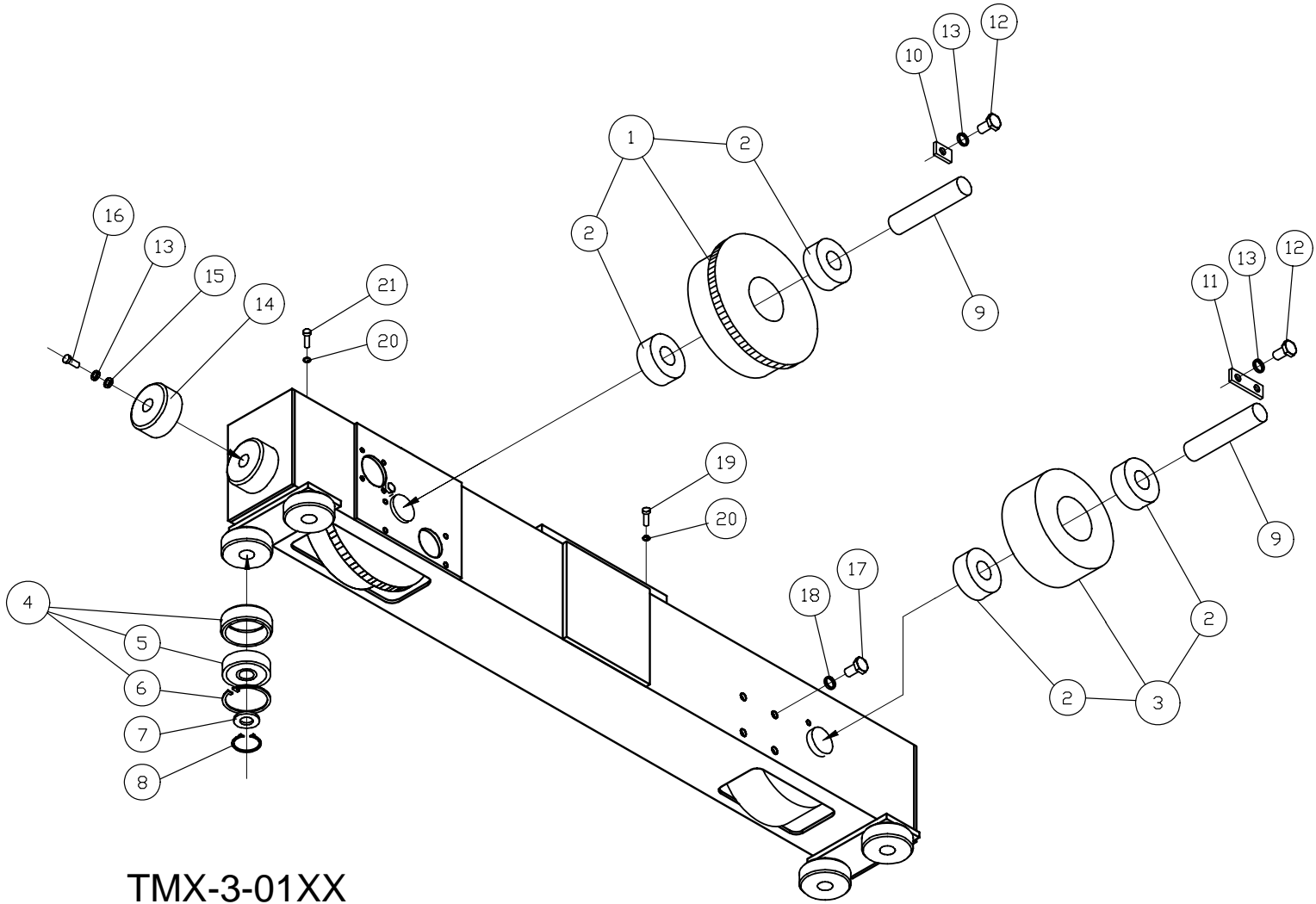

Figure 10-3 Top Running Push End Truck Parts View

Applicable End Truck Models - TP-3-0135 to 0535

Figure No.	Part Name	Quantity Per Pair	Applicable End Truck		
			TP-3-0135 to 0145	TP-3-0335 to 0245	TP-3-0535
1	Track Wheel Spacer	2	62408-01	62408-07	
2	Ball Bearing	8	90007-05 (6305-ZZ)	90007-07 (6307-ZZ)	
3	Track Wheel "B" Assembly	4	N6QO3101102	N6QO7201102	
4	Guide Roller Assembly	8	N6QO3101108		
5	Ball Bearing	8	90006-05 (6205-ZZ)		
6	Snap Ring	8	90472-52		
7	Washer	8	62324-04		
8	Snap Ring	8	90471-25		
9	Track Wheel Axle	4	62408-14	62408-15	62408-16
10	Keeper Plate	2	62408-26		
11	Shaft Stopper	[x]	62408-25 [2]	62408-25 [4]	
12	Bolt	[x]	90933-27 [6] (M8x20)	90933-27 [8] (M8x20)	
13	Spring Washer	[x]	90127-11 [10] (M8)	90127-11 [12] (M8)	
14	Buffer	4	N6QL210207		
15	Plain Washer	4	90125-14 (M10)		
16	Bolt	4	90931-01 (M8x35)		
17	Bolt	4	90933-49 (M10x25)		
18	Spring Washer	4	90127-12 (M10)		
19	Bolt	[x]	90933-73 [4] (M12x45)		90933-73 [8] (M12x45)
20	Spring Washer	[x]	90127-13 [5] (M12)		90127-13 [10] (M12)
21	Bolt	2	90933-70(M12x30)		



TMX-3-01XX

Figure 10-4 Top Running Motorized End Truck Parts View

Applicable End Truck Models - TMX-0135 TO 0560 & TG-0135 TO 0550

Figure No.	Part Name	Quantity Per Pair	Applicable End Truck			
			TML/S/H/D-3-0135 to 0160 TG-3-0135 to 0150	TML/S/H/D-3-0335 to 0360 TG-3-0335 to 0350	TML/S/H/D-3-0535 TG-3-0535	TML/S/H/D-3-0560 TG-3-0550
1	Track Wheel "A" Assembly	2	N6QO3101101	N6QO7201101		N6QO4501101
2	Ball Bearing	8	90007-05 (6305-ZZ)	90007-07 (6307-ZZ)		90007-09 (6309-ZZ)
3	Track Wheel "B" Assembly	2	N6QO3101102	N6QO7201102		N6QO4501102
4	Guide Roller Assembly	8	N6QO3101108			
5	Ball Bearing	8	90006-05 (6305-ZZ)			
6	Snap Ring	8	90472-52			
7	Washer	8	62324-04			
8	Snap Ring	8	90471-25			
9	Track Wheel Axle	2	62408-14	62408-15	62408-16	62445-17
10	Keeper Plate	2	62408-26			
11	Shaft Stopper	[x]	62408-25 [2]	62408-25 [4]		62445-13
12	Bolt	[x]	90933-27 [6] (M8X20)	90933-27 [8] (M8x20)		
13	Spring Washer	[x]	90127-11 [10] (M8)	90127-11 [12] (M8)		
14	Buffer	4	N6QL210207			N6QO375207
15	Plain Washer	4	90125-14 (M10)			
16	Bolt	4	90931-01 (M8x35)			
17	Bolt	4	90933-49 (M10x25)			
18	Spring Washer	4	90127-12 (M10)			
19	Bolt	[x]	90933-73 [4] (M12x45)	90933-73 [8] (M12x45)		90933-45 (M16x40) [8]
20	Spring Washer	[x]	90127-13 [8] (M12)	90127-13 [12] (M12)		90127-15 (M16) [8]
21	Bolt	4	909233-70 (M12x30)			

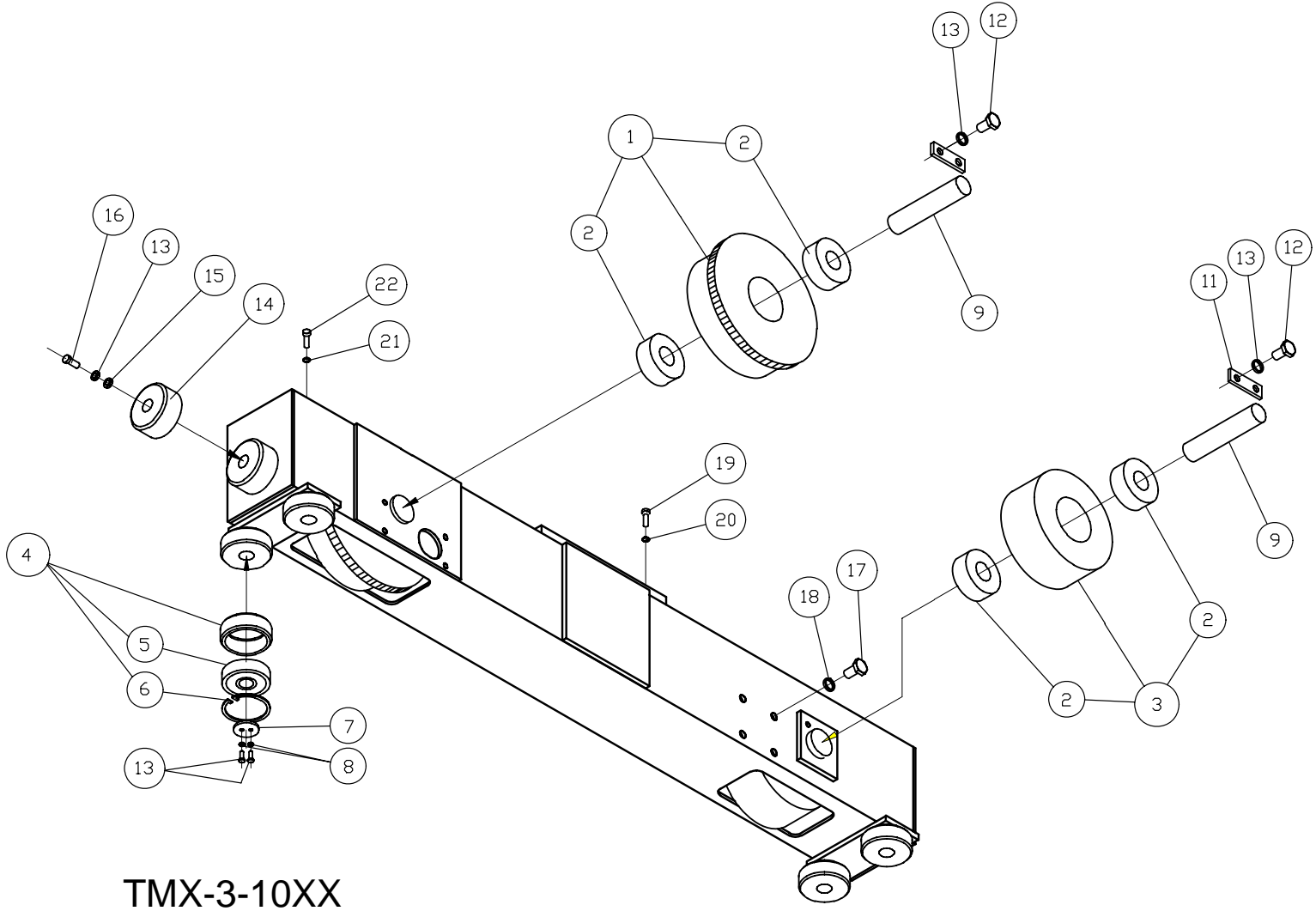

TMX-3-10XX

Figure 10-5 Top Running Motorized End Truck Parts View

Applicable End Truck Models - TMX-1035 to 1060

Figure No.	Part Name	Quantity Per Pair	Applicable End Truck
			TML/S/H/D-3-1035 to1060
1	Track Wheel "A" Assembly	2	N6QO5751101
2	Ball Bearing	8	90007-10 (6310-ZZ)
3	Track Wheel "B" Assembly	2	N6QO5751102
4	Guide Roller Assembly	8	N6QO3751108
5	Ball Bearing	8	90006-08 (6208-ZZ)
6	Snap Ring	8	90472-80
7	Washer	8	N6QO375120
8	Spring Washer	16	90127-11 (M8)
9	Track Wheel Axle	16	62445-18
11	Shaft Stopper	4	62445-13
12	Bolt	8	90933-27 (M8x20)
13	Spring Washer	12	90127-11 (M8)
14	Buffer	4	N6QO375207
15	Plain Washer	4	90125-14 (M10)
16	Bolt	4	90933-29 (M8x30)
17	Bolt	4	90933-25 (M10x25)
18	Spring Washer	4	90127-12 (M10)
19	Bolt	24	90933-160 (M20x50)
20	Spring Washer	24	90127-17 (M20)
21	Spring Washer	4	90127-13 (M12)
22	Bolt	4	90933-70 (M12x30)

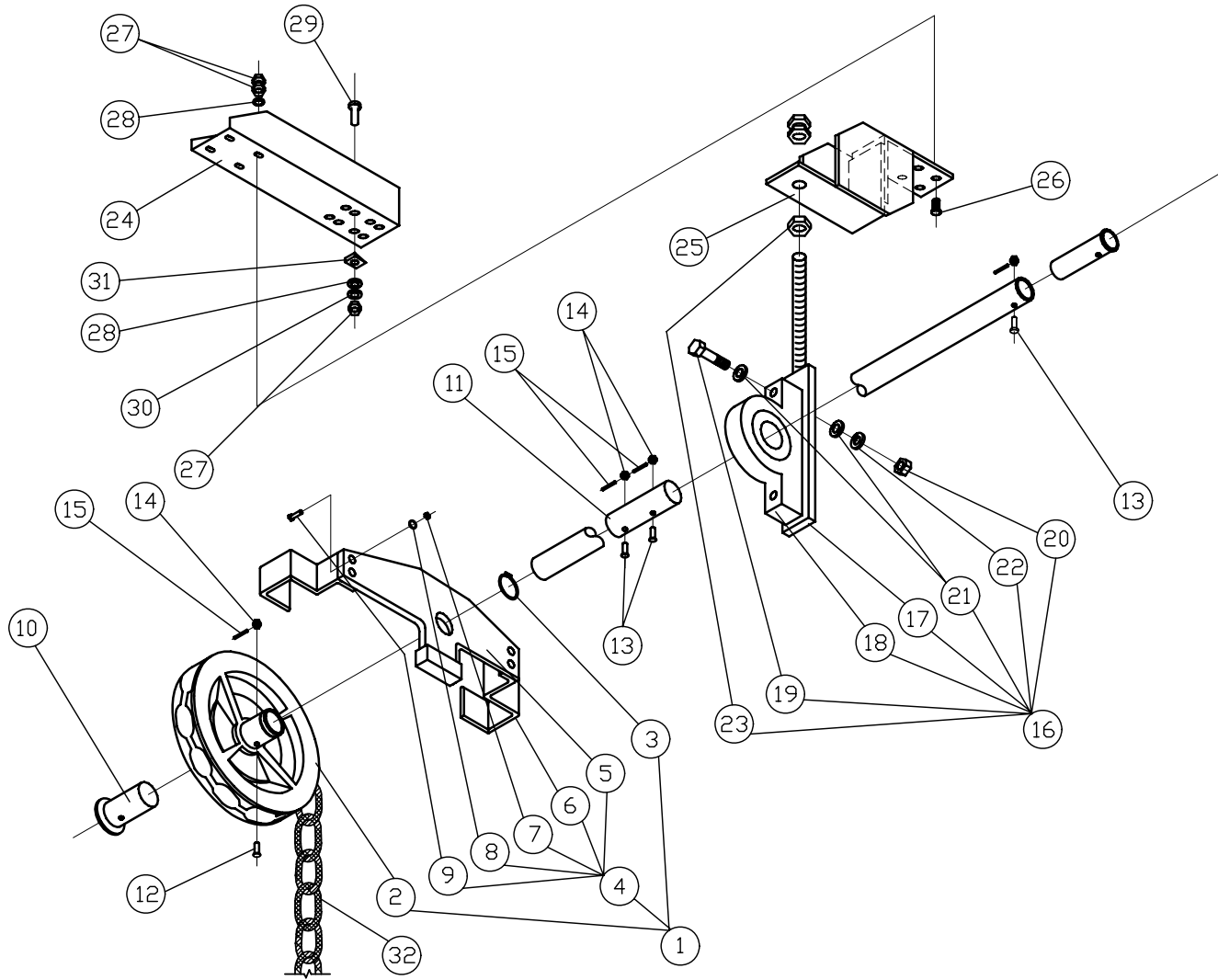

Figure 10-6 Hand Wheel and Drive Shaft Assembly Parts View

Hand Wheel and Drive Shaft Assembly Parts List

Fig.	Drawing Number	Name	Qty. Per Pair of End Trucks			
			Kit A	Kit B	Kit C	Kit D
1	N6GK2105011	Hand Wheel Assembly	1	1	1	1
2	N6GK210510	Hand Wheel	1	1	1	1
3	90471-52	Snap Ring	1	1	1	1
4	N6GK2105504	Guide Plate Assembly	1	1	1	1
5	N6GK210504	Guide Plate	1	1	1	1
6	T3GO10129	Hand Chain Guide	2	2	2	2
7	90934-24	Nut (M8x1.25)	4	4	4	4
8	90127-11	Spring Washer (M8)	4	4	4	4
9	90912-73	Socket Bolt (M8x25)	4	4	4	4
10	N6GK210523	Connecting Shaft	2	2	2	2
11	N6GK310521	Joint Shaft	--	1	2	3
12	N6GK210525	Bolt "A"	1	3	5	7
13	N6GK210526	Bolt "B"	1	1	1	1
14	90935-07	Slotted Nut (M10x1.5)	2	4	6	8
15	90094-14	Split Pin (2x18)	2	4	6	8
16	62492-1	Bearing Support Assembly	--	1	2	3
17	62492	Bearing Support Bracket Assy.	--	1	2	3
18	90115-02	Pillow Block	--	1	2	3
19	90931-89	Bolt (M16x50)	--	2	4	6
20	90934-39	Nut (M16x2.0)	--	2	4	6
21	90125-17	Washer (M16)	--	2	4	6
22	90127-15	Spring Washer (M16)	--	2	4	6
23	90934-45	Nut (M20x2.5)	--	3	6	9
24*	62490-1	Horizontal Support Bracket A	--	1	2	3
	62490-2	Horizontal Support Bracket B	--	1	2	3
	62490-3	Horizontal Support Bracket C	--	1	2	3
	62490-4	Horizontal Support Bracket D	--	1	2	3
25**	62491-1	Vertical Support Bracket Assy E	--	1	2	3
	62491-2	Vertical Support Bracket Assy F	--	1	2	3
26	90931-45	Bolt (M12x40)	--	4	8	12

65

Fig.	Drawing Number	Name	Qty. Per Pair of End Trucks			
			Kit A	Kit B	Kit C	Kit D
27	90934-33	Nut (M12x1.75)	--	8	16	24
28	90125-15	Washer (M12)	--	4	8	12
29	90933-76	Bolt (M12x60)	--	4	8	12
30	90127-13	Spring Washer (M12)	--	4	8	12
31	90435-14	"I" Tapered Washer (9°) (M12)	--	4	8	12
32	HCCF005	Hand Chain	1 Pc.	1 Pc.	1 Pc.	1 Pc.

* See note A, B, C, and D.

** See note E and F.

Note:

- A. Use with the following end truck models: UG-3-0235
- B. Use with the following end truck models: TG-3-0135, 0335, 0535 & UG-3-0335, 0535
- C. Use with the following end truck models: TG-3-0550 & UG-3-0250, 0350, 0550
- D. Use with the following end truck models: TG-3-0150, 0350
- E. Use with the following end truck models: TG-3-01xx, 03xx, 05xx & UG-3-03xx, 05xx
- F. Use with the following end truck models: UG-3-02xx

Kit A for spans less than or equal to 16 feet.

Kit B for spans greater than 16 feet and less than or equal to 32 feet.

Kit C for spans greater than 32 feet and less than or equal to 48 feet.

Kit D for spans greater than 48 feet.

This page intentionally left blank

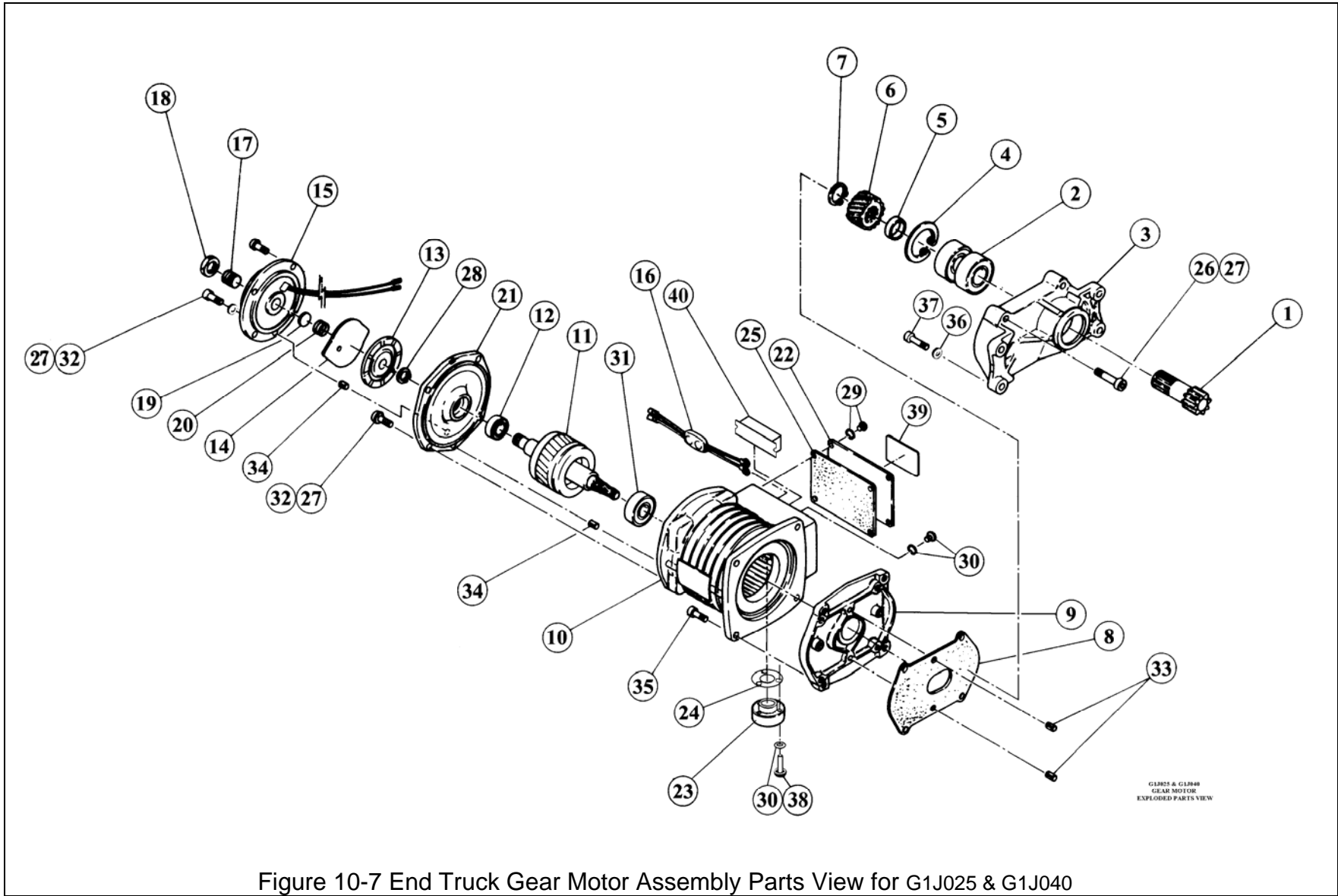

Figure 10-7 End Truck Gear Motor Assembly Parts View for G1J025 & G1J040

Applicable End Truck Gear Motor Models - G1J025 & G1J040

Fig. No.	Part Name		Qty. Per Motor	Applicable End Truck					
				0.33 Hp 40 and 80 FPM	0.5 Hp 120 FPM	0.33/0.1 Hp 80/20 FPM	0.5 Hp 40 and 80 FPM	1 Hp 120 FPM	0.5/0.13 Hp 80/20 FPM
1	Pinion	Top Running	1	N6GJ025301			N6GJ040301		
		Bottom Running	1	N6GC025301			N6GC040301		
2	Ball Bearing		2	90006-04 (6204-ZZ)			90007-05 (6305-ZZ)		
3	Gear Box "A"		1	N6GJ025303			N6GJ040303		
4	Snap Ring		1	90472-47			90472-62		
5	Collar "A"		1	N6GJ025305			N6GJ040305		
6	Gear 2	*G1 Motor Version	1	40FPM N6GJ025307L	N6GJ040307T	N6GJ025307L	40 FPM N6GJ040307L	N6GJ040307H	N6GJ040307L
		*G1 Motor Version		80 FPM N6GJ025307S			80 FPM N6GJ040307S		
		*G1D Motor Version		80 FPM N6GJ025952S			80 FPM N6GJ040952S		
7	Snap Ring		1	90471-20			90471-25		
8	Gear Box Packing		1	N6GJ025310			N6GJ040310		
9	Gear Box "B"		1	N6GJ025401			N6GJ040401		
10	Stator Assembly		1	N6GJ0255501S	N6GJ0405501T	N6GJ0255501B	N6GJ0405501S	N6GJ0755501S	N6GJ0405501B
11	Rotor Assembly	*G1 Motor Version	1	40 & 80 FPM N6GJ0255502S	N6GJ0405502T	N6GJ0255502B	40 & 80 FPM N6GJ0405502S	N6GJ0755502T	N6GJ0405502B
		*G1D Motor Version		80FPM N6GJ0255911S			80FPM N6GJ0405911S		
12	Ball Bearing		1	90006-02 (6202-ZZ)	90006-02 (6202-ZZ)		90006-02 (6202-ZZ)	90005-04 (6004-ZZ)	90006-02 (6202-ZZ)
13	Brake Disk		1	N6GJ0255512			N6GJ0755512		
14	Armature		1	N6GJ0255513			N6GJ0755513		
15	Electromagnetic Coil Assembly		1	N6GJ0255610			N6GJ0755610		
16	Rectifier		1	N6GJ025602					
17	Adjusting Bolt		1	N6GJ025603			N6GJ075603		N6GJ025603
18	Lock Nut		1	N6GJ025604			N6GJ075604		N6GJ025604
19	Spring Holder		1	N6GJ025605			N6GJ075605		N6GJ025605
20	Brake Spring		1	N6GJ040606			N6GJ075606		N6GJ040606

* The Model number on the motor data nameplate can identify the motor version as G1 or G1D.

Fig. No.	Part Name		Qty. Per Motor	Applicable End Truck					
				0.33 Hp 40 and 80 FPM	0.5 Hp 120 FPM	0.33/0.1 Hp 80/20 FPM	0.5 Hp 40 and 80 FPM	1 Hp 120 FPM	0.5/0.13 Hp 80/20 FPM
21	Brake Bracket		1	N6GJ025609	N6GJ040609			N6GJ075609	N6GJ040609
22	Terminal Cover		1	N6GJ3025701S		N6GJ025701B	N6GJ040701S		
23	Cable Holder		1	62587					
24	Cable Packing		1	62588					
25	Terminal Cover Packing		1	N6GJ025707S		N6GJ025707B	N6GJ040707S		
26	Bolt		[x]	90912-54 (M6x40) [8]	90912-54 (M6x40) [4]		90912-56 (M6x50) [4]		
27	Spring Washer		[x]	90127-09 (M6) [12]	90127-09 (M6) [16]	90127-09 (M6) [12]			
28	Snap Ring		1	90471-15			90471-20		90471-15
29	Screw w/ Spring Washer		4	MS555010					
30	Screw w/ Spring Washer		[x]	MS555010 (M4) [2]		MS555010 (M4) [4]	MS555010 (M4) [2]		MS555010 (M4) [4]
31	Ball Bearing	G1 Version	1	90010-04 40 & 80FPM	90009-05	90010-04		90009-05	90010-04
		G1D Version		90009-05 80 FPM			90010-04		
32	Bolt		[x]	90912-50 (M6x20) [4]	90912-50 (M6x20) [12]	90912-50 (M6x20) [12]	90912-50 (M6x20) [8]		90912-50 (M6x20) [8]
33	Spring Pin		2	91481-112 (M8x10)					
34	Spring Pin		2	91481-97 (M6x12)					
35	Bolt		8	90912-73 (M8x25)					
36	Spring Washer		4	90127-11 (M8)					
37	Bolt		4	UMX-0235 TO 0350 90933-29 (M8X30) TMX-0135 TO 0535 90933-30 (M8X35)			UMX 0535 TP 0550 90933-29 (M8X30) TMX-0560 90933-30 (M8X35)		
38	Screw		3	97985-26 (M4X25)					
40	7P Terminal Strip		[x]	N6GJ025B98051 [1]		E6F606003 [2]	N6GJ025B98051 [1]		E6F606003 [2]

This page intentionally left blank

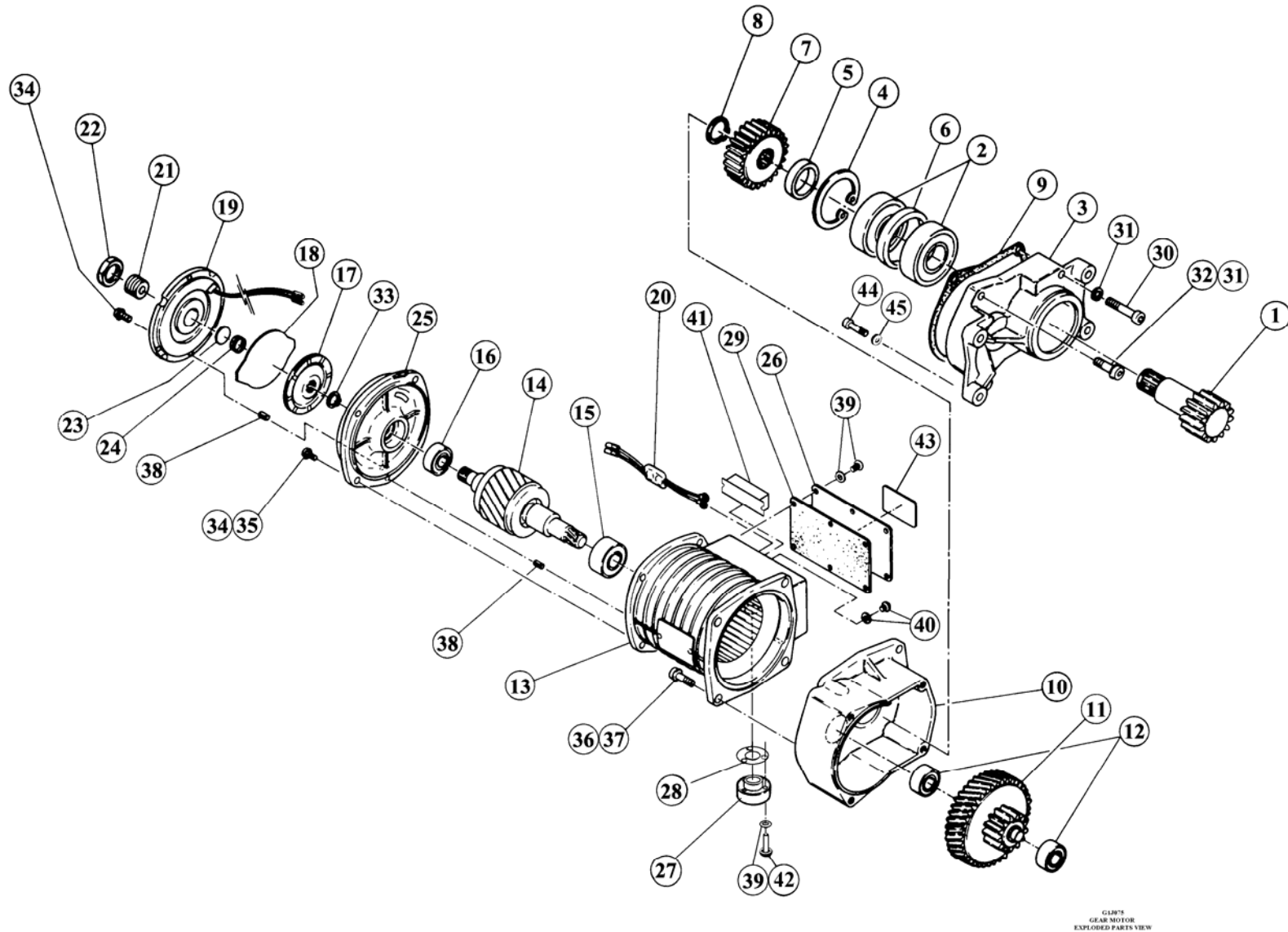

G1J075
GEAR MOTOR
EXPLODED PARTS VIEW

Figure 10-8 End Truck Gear Motor Parts View for G1J075

Applicable End Truck Gear Motor Model - G1J075 & G1J150

Fig. No.	Part Name	Qty. Per Motor	Applicable End Truck		
			1.0 HP 40 and 80 FPM	2.0 HP 120 FPM	1.0/0.6 HP 80/20 FPM
1	Pinion	1	N6GJ075301		
2	Ball Bearing	2	90007-06 (6306-ZZ)		
3	Gear Box "A"	1	N6GJ075303		
4	Snap Ring	1	90472-100		
5	Collar "A"	1	N6GJ075305		
6	Collar "B"	1	N6GJ075306		
7	Gear 4	*G1 Motor Version	40 FPM N6GJ075411L	N6GJ075411H	N6GJ075411L
		*G1 Motor Version	80 FPM N6GJ075411S		
		*G1D Motor Version	80 FPM N6GJ075954S	N6GJ150954H	
8	Snap Ring	1	90471-30		
9	Gear Box Packing	1	N6GJ075310		
10	Gear Box "B"	1	N6GJ075401		
11	Gear 2	*G1 Motor Version	40 FPM N6GJ075307L	N6GJ075307H	N6GJ075307L
		*G1 Motor Version	80FPM N6GJ075307S		
		*G1D Motor Version	80 FPM N6GJ075921S	N6GJ150921H	
12	Ball Bearing	2	90006-03 (6203-ZZ)		
13	Stator Assembly	1	N6GJ0755501S	N6GJ1505501T	N6GJ0755501B
14	Rotor Assembly	*G1 Motor Version	40 & 80FPM N6GJ0755502S	N6GJ1505502T	N6GJ0755502B
		*G1D Motor Version	80 FPM N6GJ0755911S	N6GJ1505911T	
15	Ball Bearing	G1 Motor Version	40 & 80FPM 90010-04	90011-05	90010-04
		G1D Motor Version	80FPM 90009-05	90010-06	

* The Model number on the motor data nameplate can identify the motor version as G1 or G1D.

Fig. No.	Part Name	Qty. Per Motor	Applicable End Truck		
			1.0 HP 40 and 80 FPM	2.0 HP 120 FPM	1.0/0.6 HP 80/20 FPM
16	Ball Bearing	1	90006-04 (6204-ZZ)		
17	Brake Disk	1	N6GJ075512		
18	Armature	1	N6GJ075513		
19	Electromagnetic Coil Assembly	1	N6GJ0755610	N6GJ1505610	N6GJ0755610
20	Rectifier	1	N6GJ025602		
21	Adjusting Bolt	1	N6GJ075603		
22	Lock Nut	1	N6GJ075604		
23	Spring Holder	1	N6GJ075605		
24	Brake Spring	1	N6GJ075606	N6GJ150606	N6GJ075606
25	Brake Bracket	1	N6GJ075609	N6GJ150609	N6GJ075609
26	Terminal Cover	1	N6GJ040701S	N6GJ150701S	N6GJ040701S
27	Cable Holder	1	62587		
28	Cable Packing	1	62588		
29	Terminal Cover Packing	1	N6GJ040707S	N6GJ150707S	N6GJ040707S
30	Bolt	2	90912-81 (M8x65)		
31	Lock Washer	8	90127-11 (M8)		
32	Bolt	6	90912-74 (M8x30)		
33	Snap Ring	1	90471-20		
34	Bolt	7	90912-50 (M6x20)		
35	Spring Washer	7	90127-09 (M6)		
36	Bolt	4	90912-72 (M8x20)		
37	Spring Washer	4	90127-11 (M8)		
38	Spring Pin	2	91481-97 (M6x12)		
39	Screw w/ Spring Washer	4	MS555010 (M4)		
40	Screw w/ Spring Washer	[X]	MS555010 (M4x10) [2]		MS555010 (M4x10) [4]
41	7P Terminal Strip	[X]	N6GJ025B98051 [1]		E6F606003 [2]
42	Screw	3	97985-26 (M4x25)		

This page intentionally left blank

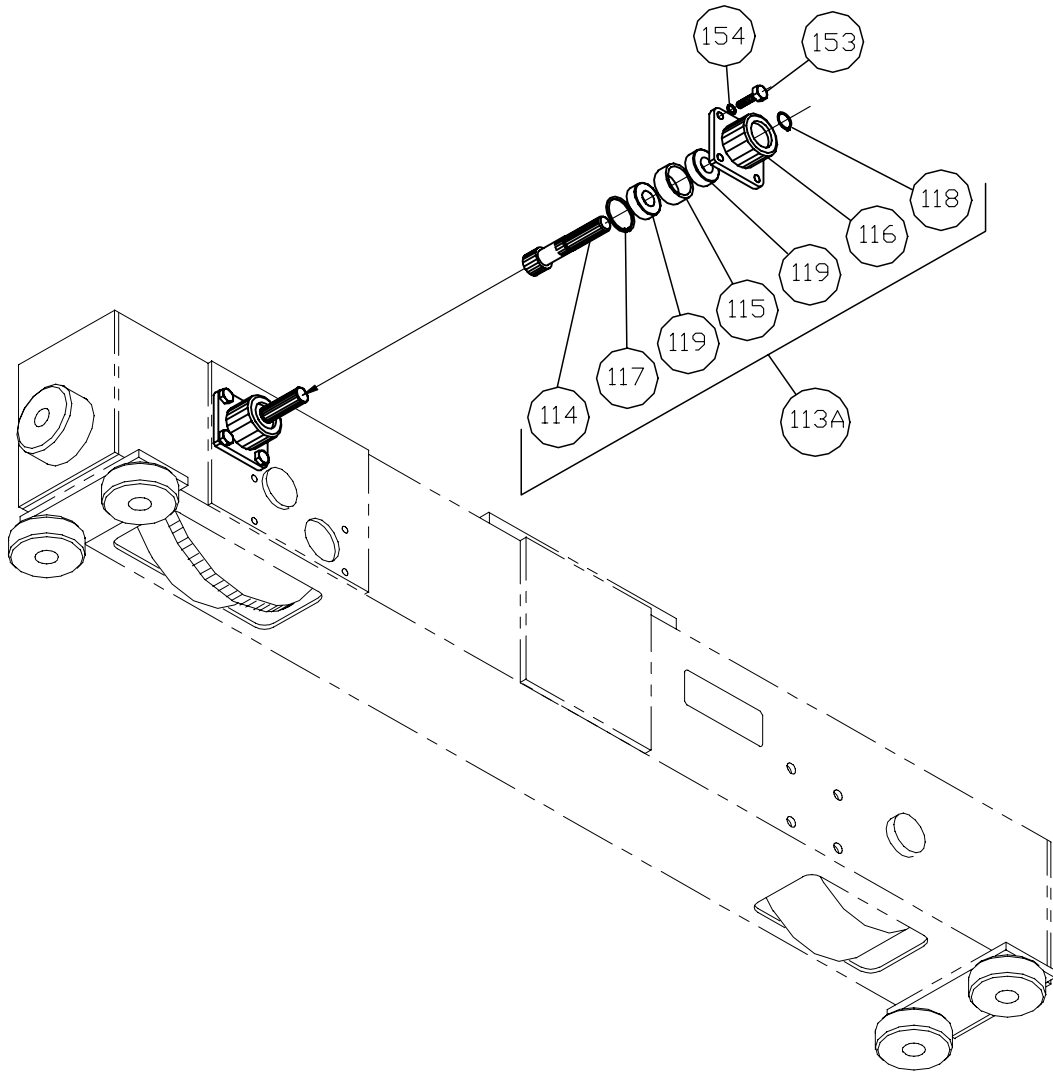

Figure 10-9 End Truck Gear Head Assembly Parts View

Applicable End Truck Models: UG-3-03xx, TG-3-01xx, & TG-3-0535

Fig. No.	Drawing/ Part No.	Name	Qty. Parts per Pair of End Trucks	Notes
113A	N6GO310V5303	Gear Head Assembly	2	
114	N6GO310V301	Pinion Axle "G"	2	
115	N6GO310306	Collar	2	
116	N6GO310303	Axle Holder	2	
117	90472-42	Snap Ring	2	
118	90471-20	Snap Ring	2	
119	90005-04	Ball Bearing	4	6004-ZZ
153	90933-27	Bolt	8	M8x20 UG-03XX
	90933-28			M8x25 TG-01xx thru 0535
154	90127-11	Spring Washer	8	M8

77

Applicable End Truck Models: UG-3-05xx & TG-3-0550

Fig. No.	Drawing/ Part No.	Name	Qty. Parts per Pair of End Trucks	Notes
113A	N6GO4505303	Gear Head Assembly	2	
114	N6GO450301	Pinion Axle "G"	2	
115	N6GO310306	Collar	2	
116	N6GO310303	Axle Holder	2	
117	90472-42	Snap Ring	2	
118	90471-20	Snap Ring	2	
119	90005-04	Ball Bearing	4	6004-ZZ
153	90933-27	Bolt	8	M8x20
154	90127-11	Spring Washer	8	M8



www.harringtonhoists.com

Harrington Hoists, Inc.
401 West End Avenue
Manheim, PA 17545
Phone: 717-665-2000
Toll Free: 800-233-3010
Fax: 717-665-2861

Harrington Hoists - Western Division
2341 Pomona Rd. #103
Corona, CA 92880
Phone: 951-279-7100
Toll Free: 800-317-7111
Fax: 951-279-7500

ET3OM