

---

# OWNER'S MANUAL

---

## MOTORIZED TROLLEY MR SERIES

1 Ton through 20 Ton Capacity

Code, Lot and Serial Number

### **WARNING**

This equipment should not be installed, operated or maintained by any person who has not read and understood all the contents of this manual. Failure to read and comply with the contents of this manual can result in serious bodily injury or death, and/or property damage.

**HARRINGTON**  
HOISTS AND CRANES

# Table of Contents

<b>Section</b>	<b>Page Number</b>
1.0 Important Information and Warnings.....	4
1.1 Terms and Summary	
1.2 Warning Tags and Labels	
2.0 Technical Information .....	8
2.1 Specifications	
2.2 Dimensions	
3.0 Pre-operational Procedures.....	10
3.1 Assembly and Adjustment	
3.2 Mounting Location	
3.3 Installation of Trolley onto Beam	
3.4 Electrical Connections	
3.5 Pre-operational Checks and Trial Operation	
4.0 Operation.....	25
4.1 Introduction	
4.2 Shall's and Shall Not's for Operation	
4.3 Trolley and Hoist Controls	
5.0 Inspection.....	28
5.1 General	
5.2 Inspection Classification	
5.3 Frequent Inspection	
5.4 Periodic Inspection	
5.5 Occasionally Used Trolleys	
5.6 Inspection Records	
5.7 Inspection Methods and Criteria	

<b>Section</b>	<b>Page Number</b>
6.0 Maintenance & Handling.....	34
6.1 Lubrication	
6.2 Brake	
6.3 Storage	
6.4 Outdoor Installation	
7.0 Troubleshooting.....	35
8.0 Warranty.....	36
9.0 Parts List.....	37
9.1 Electrical Parts	
9.2 Pendant Parts	
9.3 Power Supply Parts	
9.4 Side Plate and Suspension Parts	
9.5 Motor Parts	

## 1.0 Important Information and Warnings

### 1.1 Terms and Summary

**This manual provides important information** for personnel involved with the installation, operation and maintenance of this product. Although you may be familiar with this or similar equipment, it is strongly recommended that you read this manual before installing, operating or maintaining the product.

**Danger, Warning, Caution and Notice** - Throughout this manual there are steps and procedures that can present hazardous situations. The following signal words are used to identify the degree or level of hazard seriousness.

**⚠ DANGER** Danger indicates an imminently hazardous situation which, if not avoided, **will** result in **death or serious injury**, and property damage.

**⚠ WARNING** Warning indicates an imminently hazardous situation which, if not avoided, **could** result in **death or serious injury**, and property damage.

**⚠ CAUTION** Caution indicates a potentially hazardous situation which, if not avoided, **may** result **minor or moderate injury** or property damage.

**NOTICE** Notice is used to notify people of installation, operation, or maintenance information which is important but not directly hazard-related.

### **⚠ CAUTION**

These general instructions deal with the normal installation, operation, and maintenance situations encountered with the equipment described herein. The instructions should not be interpreted to anticipate every possible contingency or to anticipate the final system, crane, or configuration that uses this equipment. For systems using the equipment covered by this manual, the supplier and owner of the system are responsible for the system's compliance with all applicable industry standards, and with all applicable federal, state and local regulations/codes.

This manual includes instructions and parts information for a variety of trolley and hoist types. Therefore, all instructions and parts information may not apply to any one type or size of specific trolley or hoist. Disregard those portions of the instructions that do not apply.

Record your trolley's Code, Lot and Serial Number on the front cover of this manual for identification and future reference to avoid referring to the wrong manual for information or instructions on installation, operation, inspection, maintenance, or parts.

Use only Harrington authorized replacement parts in the service and maintenance of this trolley.

## **WARNING**

Equipment described herein is not designed for and **MUST NOT** be used for lifting, supporting, or transporting people, or for lifting or supporting loads over people.

Equipment described herein should not be used in conjunction with other equipment unless necessary and/or required safety devices applicable to the system, crane, or application are installed by the system designer, system manufacturer, crane manufacturer, installer, or user.

Modifications to upgrade, rerate, or otherwise alter this equipment shall be authorized only by the original equipment manufacturer.

Equipment described herein may be used in the design and manufacture of cranes or monorails. Additional equipment or devices may be required for the crane and monorail to comply with applicable crane design and safety standards. The crane designer, crane manufacturer, or user is responsible to furnish these additional items for compliance. Refer to ANSI/ASME B30.17, "Safety Standard for Top-Running Single Girder Cranes"; ANSI/ASME B30.2 "Safety Standard for Top-Running Double-Girder Cranes"; and ANSI/ASME B30.11 "Safety Standard for Underhung Cranes and Monorails".

If a below-the-hook lifting device or sling is used with a hoist, refer to ANSI/ASME B30.9, "Safety Standard for Slings" or ANSI/ASME B30.20, "Safety Standard for Below-the-Hook Lifting Devices".

Hoists, trolleys and cranes, used to handle hot molten material may require additional equipment or devices. Refer to ANSI Z241.2, "Safety Requirements for Melting and Pouring of Metals in the Metalcasting Industry".

Electrical equipment described herein is designed and built in compliance with Harrington's interpretation of ANSI/NFPA 70, "National Electrical Code". The system designer, system manufacturer, crane designer, crane manufacturer, installer, or user is responsible to assure that the installation and associated wiring of these electrical components is in compliance with ANSI/NFPA 70, and all applicable Federal, State and Local Codes.

Failure to read and comply with any one of the limitations noted herein can result in serious bodily injury or death, and/or property damage.

## **DANGER**

**HAZARDOUS VOLTAGES ARE PRESENT IN THE CONTROL BOX, OTHER ELECTRICAL COMPONENTS, AND CONNECTIONS BETWEEN THESE COMPONENTS.**

Before performing ANY mechanical or electrical maintenance on the equipment, de-energize (disconnect) the main switch supplying power to the equipment; and lock and tag the main switch in the de-energized position. Refer to ANSI Z244.1, "Personnel Protection – Lockout/Tagout of Energy Sources".

Only trained and competent personnel should inspect and repair this equipment.

## **NOTICE**

It is the responsibility of the owner/user to install, inspect, test, maintain, and operate a trolley or hoist in accordance with ANSI/ASME B30.16, "Safety Standard for Overhead Hoists", OSHA Regulations and ANSI/NFPA 70, "National Electric Code". If the trolley is installed as part of a total lifting system, such as an overhead crane or monorail, it is also the responsibility of the owner/user to comply with the applicable ANSI/ASME B30 volume that addresses that type of equipment.

It is the responsibility of the owner/user to have all personnel that will install, inspect, test, maintain, and operate a hoist read the contents of this manual and applicable portions of ANSI/ASME B30.16, "Safety Standard for Overhead Hoists", OSHA Regulations and ANSI/NFPA 70, "National Electric Code". If the trolley is installed as part of a total lifting system, such as an overhead crane, the applicable ANSI/ASME B30 volume that addresses that type of equipment must also be read by all personnel.

If the trolley owner/user requires additional information, or if any information in the manual is not clear, contact Harrington or the distributor of the trolley. Do not install, inspect, test, maintain, or operate this trolley unless this information is fully understood.

A regular schedule of inspection of the trolley in accordance with the requirements of ANSI/ASME B30.16 should be established and records maintained.

## 1.2 Warning Tag and Labels

The warning tag illustrated below in [Figure 1-1](#) is supplied with each trolley shipped from the factory. If the tag is not attached to the pendant cord for your hoist/trolley, order a tag from your dealer and install it. Read and obey all warnings attached to this trolley. Tag is not shown actual size.

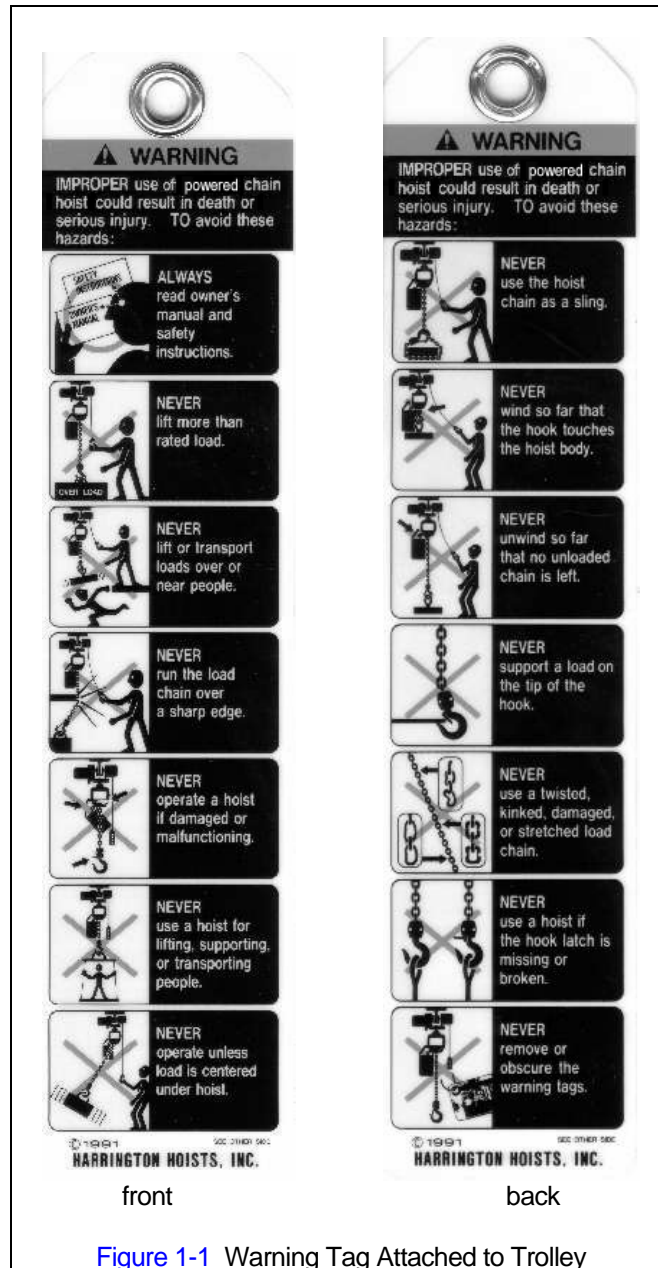
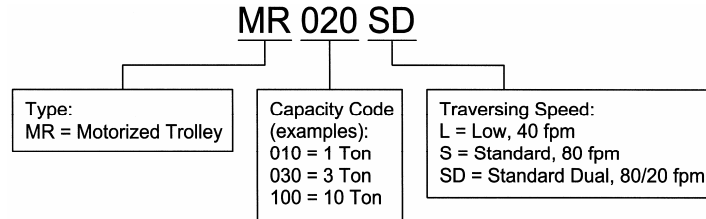


Figure 1-1 Warning Tag Attached to Trolley

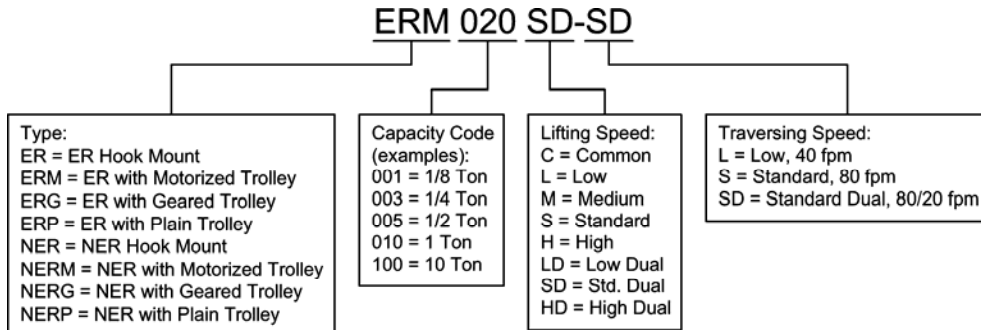
## 2.0 Technical Information

### 2.1 Specifications

#### 2.1.1 Product Code for MR Trolley Alone:



#### 2.1.2 Product Code for MR Trolley with ER Series Electric Hoist:



**Table 2-1 Trolley Specifications**

	Capacity (Ton)	Code	Standard Beam Flange Range (in)	Optional Beam Flange Range (in)	Min. Allowable Radius for Curve (in)	Motor			Approx. Net Weight (lbs)
						Output (Hp)	Current Draw (amps)		
							208V or 230V	460V	
SINGLE SPEED	1	MR010L/S	2.28 to 5.00	5.01 to 6.02 <u>OR</u> 6.03 to 12.00	31.5	0.5	3.2	1.6	66
	2	MR020L/S	3.23 to 6.02	6.03 to 7.02 <u>OR</u> 7.03 to 12.00	31.5	0.5	3.2	1.6	84
	3	MR030L/S	3.23 to 6.02	6.03 to 7.02 <u>OR</u> 7.03 to 12.00	39.4	0.5	3.2	1.6	104
	5	MR050L/S	3.94 to 7.01	7.02 to 7.60 <u>OR</u> 7.61 to 12.00	70.9	1.0	5.1	2.5	157
	8	MR080L	5.91 to 8.66	8.67 to 12.00	98.4	1.0	5.1	2.5	315
	10	MR100L	5.91 to 8.66	8.67 to 12.00	98.4	1.0	5.1	2.5	315
	15	MR150L	5.91 to 8.66	8.67 to 12.00	∞	1.0 x 2	5.1 x 2	2.5 x 2	611
	20	MR200L	5.91 to 8.66	8.67 to 12.00	∞	1.0 x 2	5.1 x 2	2.5 x 2	633
DUAL SPEED	1	MR010SD	2.28 to 5.00	5.01 to 6.02 <u>OR</u> 6.03 to 12.00	31.5	0.4/0.1	2.9/2.2	1.5/1.1	75
	2	MR020SD	3.23 to 6.02	6.03 to 7.02 <u>OR</u> 7.03 to 12.00	31.5	0.4/0.1	2.9/2.2	1.5/1.1	93
	3	MR030SD	3.23 to 6.02	6.03 to 7.02 <u>OR</u> 7.03 to 12.00	39.4	0.9/0.2	3.6/3.1	1.8/1.6	110
	5	MR050SD	3.94 to 7.01	7.02 to 7.60 <u>OR</u> 7.61 to 12.00	70.9	0.9/0.2	3.6/3.1	1.8/1.6	165

### 2.1.3 Operating Conditions and Environment

Temperature Range: -4° to +104°F (-20° to +40°C)

Humidity: 85% or less

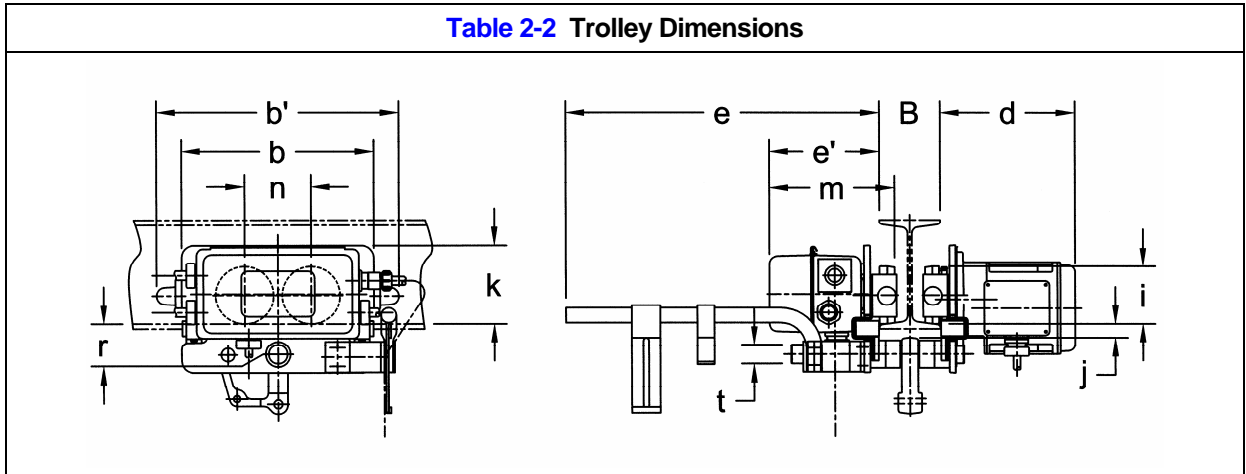
Enclosure Rating: Trolley Meets IP 55, Pendant Meets IP 65

Supply Voltage: Standard 208-230/460V-3-60, Optional 575V-3-60, Special Voltages Available

Intermittent Duty Rating: Single Speed - 40% ED 240 starts per hour

Dual Speed - 40/20% ED with 120/240 starts per hour

## 2.2 Dimensions



	Code	b	b'	d	e	e'	i	j	k	m	n	r	t
Single Speed	MR010L/S	12.4	15.6	8.7	20.3	7.0	3.74	0.9	5.1	8.0	4.3	2.0	1.22
	MR020L/S	12.8	16.4	8.9	20.5	7.2	4.33	1.1	4.9	8.3	4.6	2.4	1.42
	MR030L/S	13.4	17.4	8.9	20.5	7.3	4.92	1.1	5.2	8.5	5.2	2.7	1.69
	MR050L/S	15.7	19.8	11.1	20.8	7.6	5.51	1.7	5.7	9.2	5.9	3.4	2.13
	MR080L	19.7	22.9	11.2	20.9	8.6	6.89	3.5	6.9	10.4	7.5	6.0	2.76
	MR100L	19.7	22.9	11.2	20.9	8.6	6.89	3.1	6.9	10.4	7.5	6.0	2.76
	MR150L	40.2	43.4	11.2	20.9	8.6	6.89	3.3	6.9	10.4	28.0	6.0	2.76
	MR200L	40.2	43.4	11.2	20.9	8.6	6.89	3.1	6.9	10.4	28.0	6.0	2.76
Dual Speed	MR010SD	12.4	15.6	10.6	20.3	7.0	3.74	0.9	5.1	8.0	4.3	2.0	1.22
	MR020SD	12.8	16.4	10.7	20.5	7.2	4.33	1.1	4.9	8.3	4.6	2.4	1.42
	MR030SD	13.4	17.4	10.8	20.5	7.3	4.92	1.1	5.2	8.5	5.2	2.7	1.69
	MR050SD	15.7	19.8	11.1	20.8	7.6	5.51	1.7	5.7	9.2	5.9	3.4	2.13

## 3.0 Pre-operational Procedures

### 3.1 Assembly and Adjustment

3.1.1 When the MR trolley is combined with a hoist, follow and complete all pre-operational procedures provided with the hoist. For Harrington ER and NER model hoists, follow the pre-operational procedures in the ER/NER Owner's Manual in conjunction with all information provided in this section for mounting and electrical connections.

3.1.2 In addition to the information and procedures provided in this section for the MR trolley, there are specific details for using ER and NER hoists with MR trolleys. Special mounting and wiring considerations must be taken if the trolley is used with a hoist other than an ER or NER model.

3.1.3 **⚠ WARNING** Never attempt to hook mount a hoist directly to the Suspension Shaft on trolleys up to and including 5 Ton. These trolleys are designed to be used with a suspender only and do not have the vertical clearance required for a hook to fit between the Suspension Shaft and trolley beam.

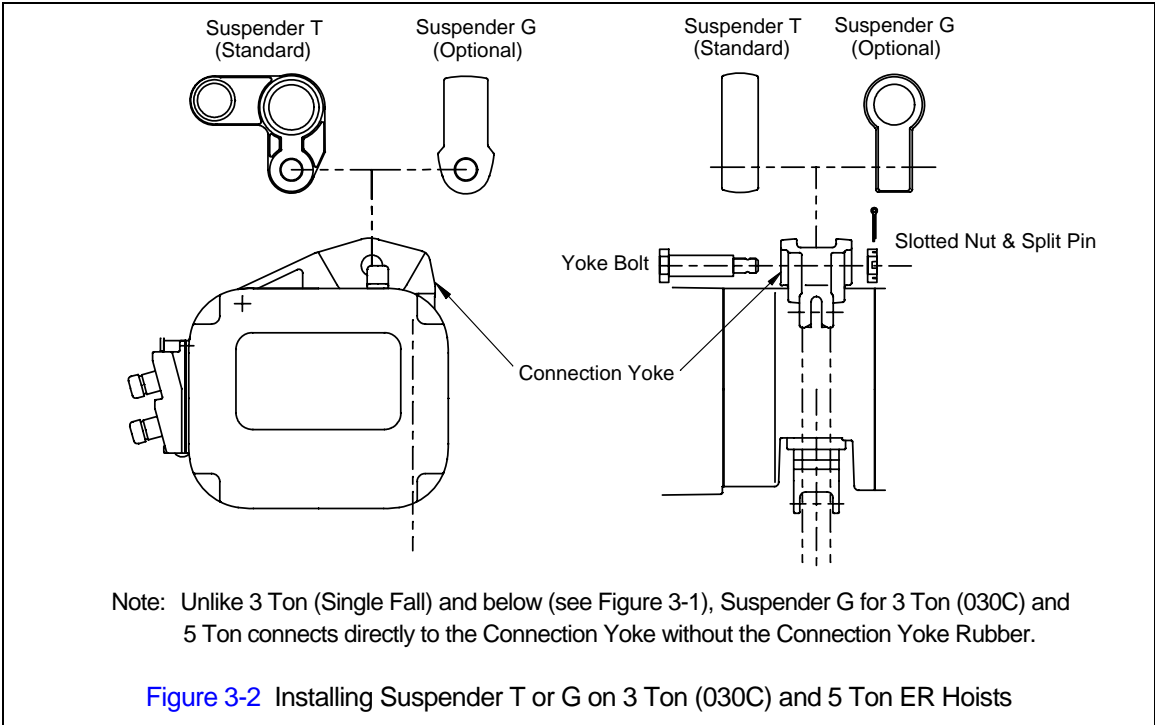
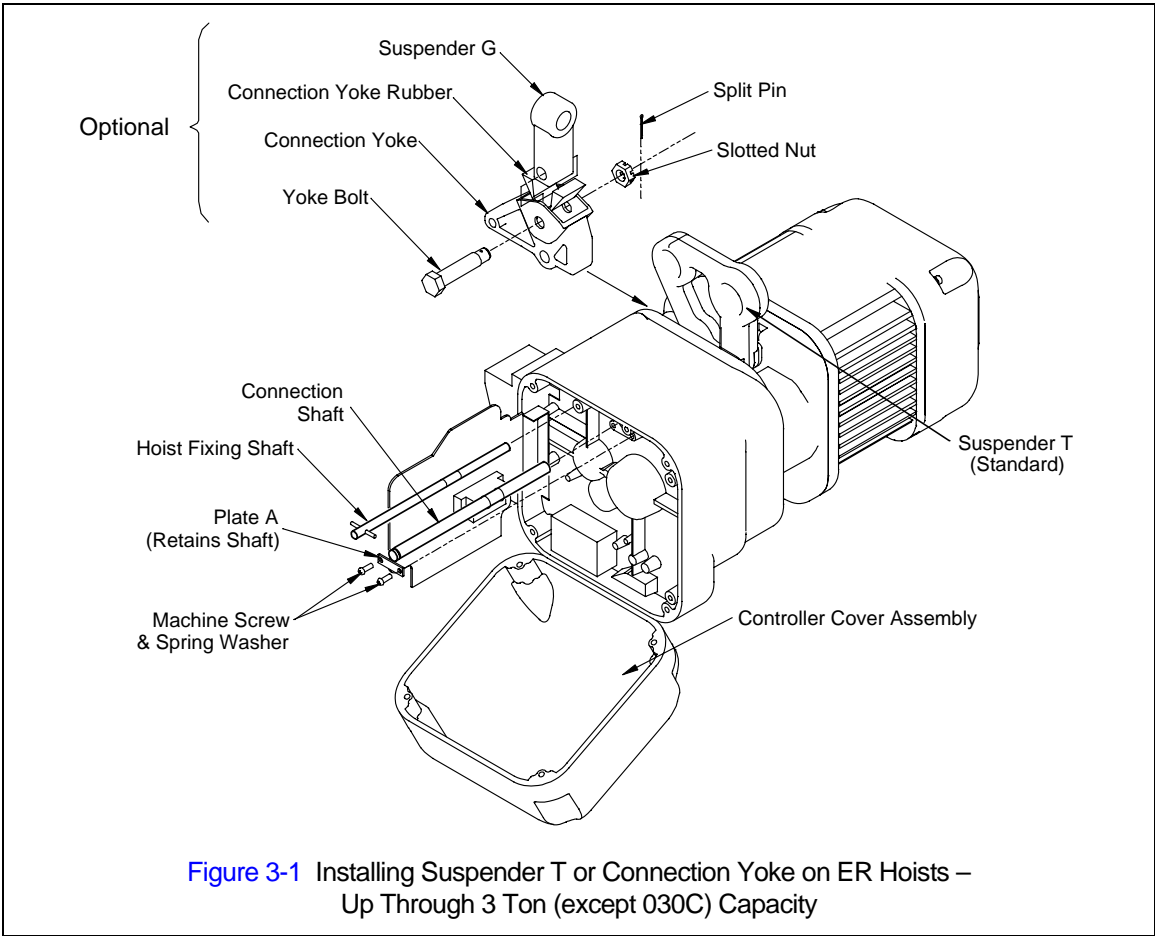
3.1.4 Preparing ER and NER hoists for use with MR trolley.

**1/8 to 3 Ton ER/NER** – The standard suspension configuration uses Suspender T which orients the hoist perpendicular to the trolley beam. Optional two-piece suspension method uses a Connection Yoke and Suspender G, which orients the hoist parallel to the trolley beam. If the hoist is not equipped with Suspender T or the Connection Yoke from the factory, remove the Top Hook Assembly from the hoist and install Suspender T or the Connection Yoke as follows:

- 1) Refer to [Figure 3-1](#).
- 2) Remove the four Controller Cover socket head bolts and allow the cover to swing fully open.
- 3) Loosen the three or four captive screws holding the electrical component mounting Plate against the main body of the hoist and swing the plate out to access the required components.
- 4) Loosen one of two Machine Screws attaching Plate A and remove the second Machine Screw. Allow Plate A to rotate out from the retaining slot in the bottom side of the Connection Shaft. Pull out the Connection Shaft and remove the Top Hook Assembly.
- 5) Remove the Hoist Fixing Shaft.
- 6) Place Suspender T or the Connection Yoke on the top of the hoist. Line up the holes for the Connection Shaft and the Hoist Fixing Shaft and reinsert the shafts.
- 7) Reassemble the remaining hoist components in reverse order of disassembly.
- 8) If installing the Connection Yoke, place the Connection Yoke Rubber and Suspender G in the top of the Connection Yoke. Attach Suspender G to the Connection Yoke with the Yoke Bolt, Slotted Nut and Split Pin (cotter pin).
- 9) There are two oil fill holes located in the top of the gear case on the ER hoist. For ER coupled to MR trolley, there are some flange widths where it will be necessary to relocate the oil cap assembly to the other oil fill hole. This will prevent interference with trolley side plate.

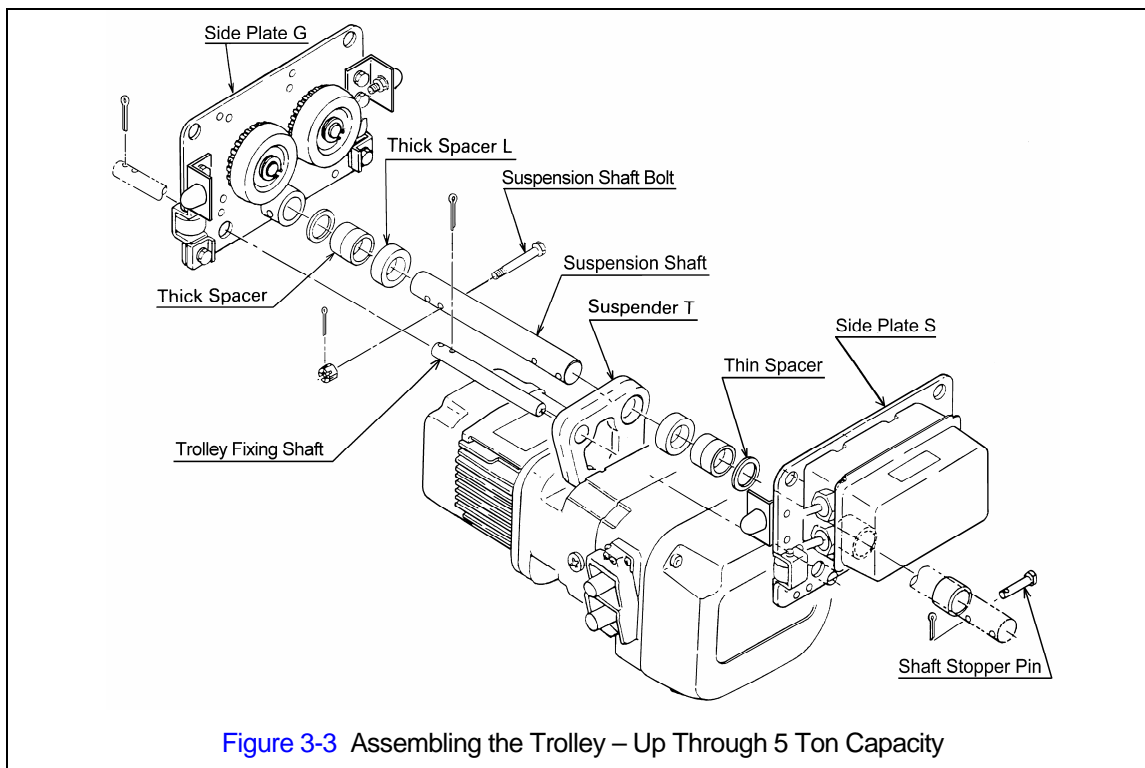
**3 Ton (030C) and 5 Ton ER/NER** – The 3 Ton (030C) and 5 Ton ER/NER hoists (double fall) always use a Connection Yoke. The standard suspension configuration uses Suspender T which orients the hoist perpendicular to the trolley beam. Suspender G is available as an option and orients the hoist parallel to the trolley beam. If the hoist is not equipped with Suspender T or G from the factory, remove the Top Hook Assembly from the Connection Yoke and install the Suspender T or G as shown in [Figure 3-2](#).

**8 to 20 Ton ER/NER** – Since the trolley suspension shaft(s) passes through the hoist top plates, no additional hoist preparation is required to mount the ER hoist to the trolley. Hook mount ER hoists can not be converted to lug mount without replacing the hoist's top Suspension Plates.

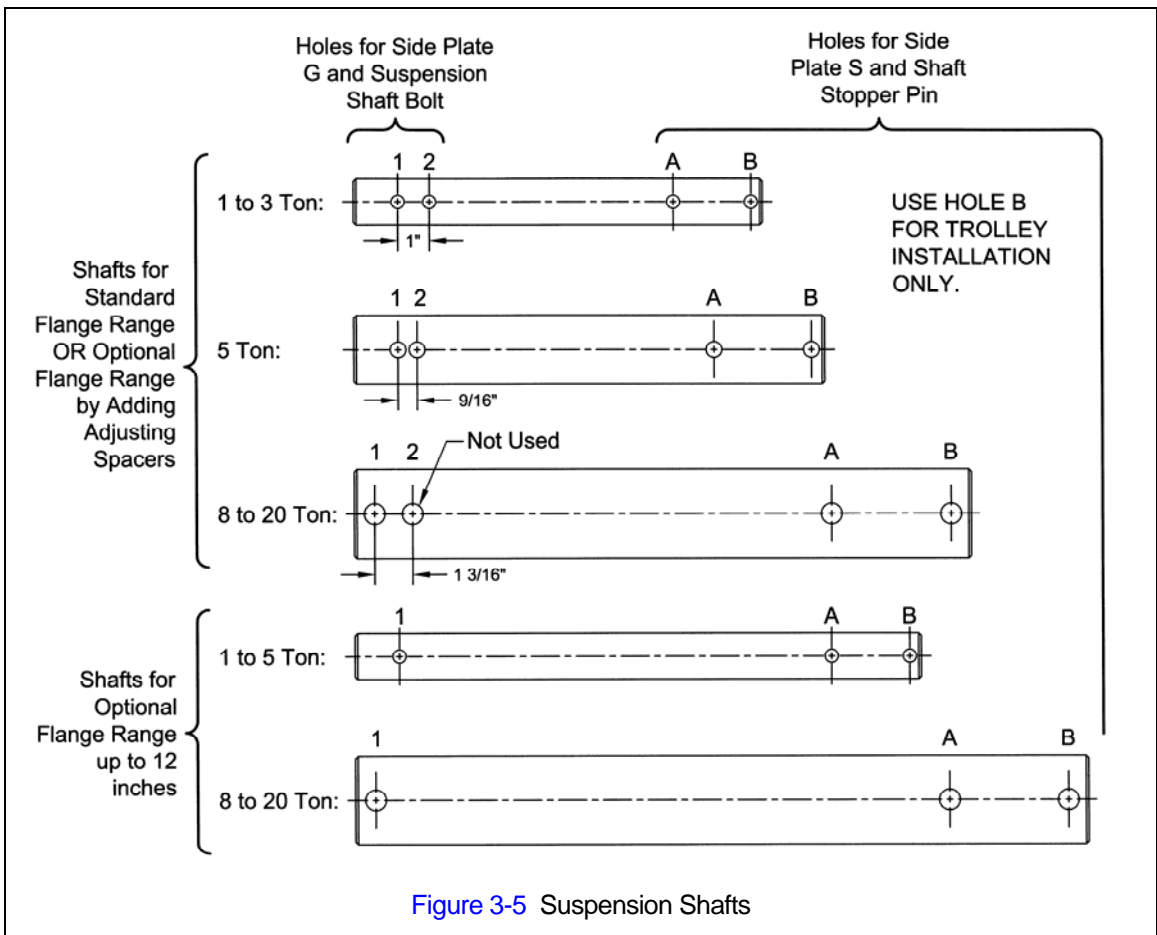
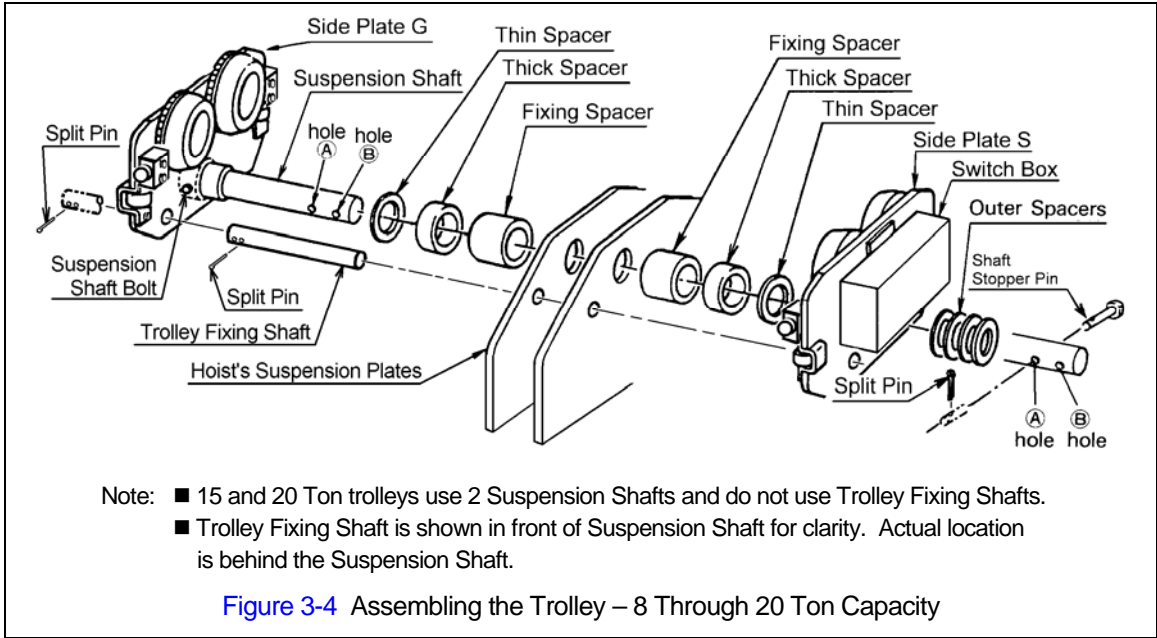


### 3.1.5 Trolley Assembly

- 1) Refer to [Figure 3-3 or 3-4](#).
- 2) Remove the Shaft Stopper Pin, Side Plate S, and Spacers from the Suspension Shaft. For beam flanges that are wider than the standard range, different suspension shaft and/or spacer arrangements are provided. Refer to [Table 3-1](#).
- 3) Insert the Suspension Shaft to Side Plate G and attach it with the Suspension Shaft Bolt, Slotted Nut and Split Pin (cotter pin). Refer to [Figure 3-5](#) and insure that correct Suspension Shaft holes are used. Securely bend both branches of the Split Pin after insertion.
- 4) Referring to [Figure 3-8](#), [Table 3-1](#) and [Table 3-2](#) install the inner adjusting Spacers and Suspender (Suspension Plates for 8 to 20 Ton) on the Suspension Shaft. Use all of the Spacers provided with the trolley. If the beam width is not listed in [Table 3-2](#), use the next size smaller and make adjustments in accordance with [Section 3.1.6](#).
- 5) Place Side Plate S into the Suspension Shaft.
- 6) Install the outer adjusting Spacers on the Suspension Shaft outside of Side Plate S. Insert the Shaft Stopper Pin into Hole "A" so that Split Pin is to the left when seen from the front side of trolley switch box. Temporarily install the split pin in the Shaft Stopper Pin and bend the split pin slightly to hold it in place. The split pin should be fully bent after checking and attaining the proper beam flange adjustment.
- 7) For ER Hoists up through 5 Ton with Suspender T - Insert the Trolley Fixing Shaft through Side Plate G, Suspender T and Side Plate S. Secure it to Side Plate G with the two split pins. Securely bend both branches of the Split Pin after insertion.
- 8) For 8 and 10 Ton ER Hoists - Insert the Trolley Fixing Shaft through Side Plate G, Suspension Plates and Side Plate S. Secure it to Side Plate G with two split pins. Securely bend both branches of the Split Pin after insertion.

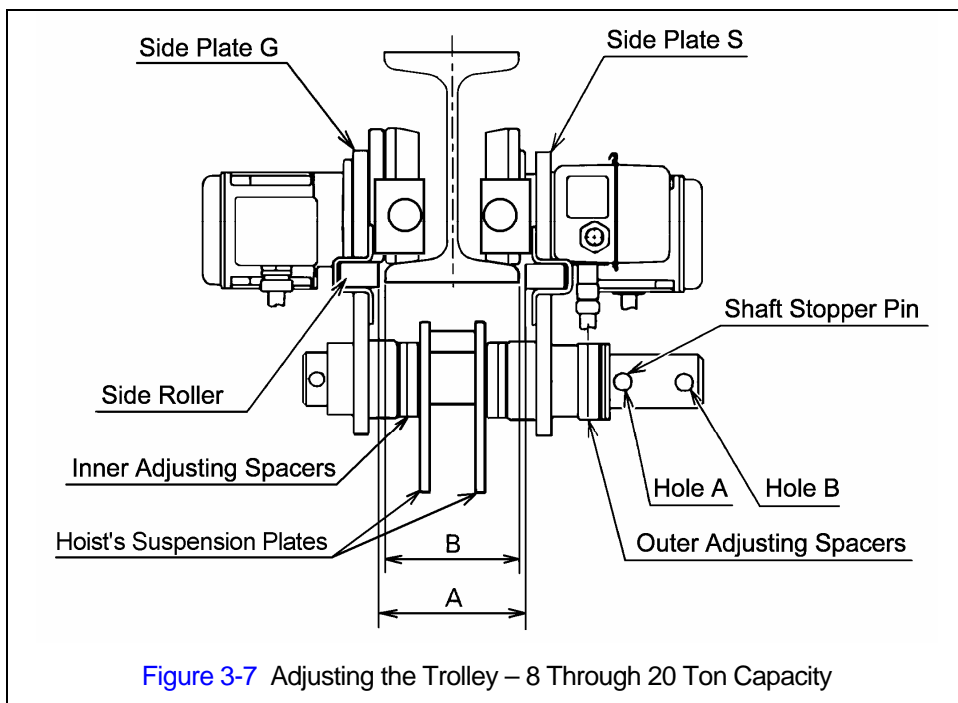
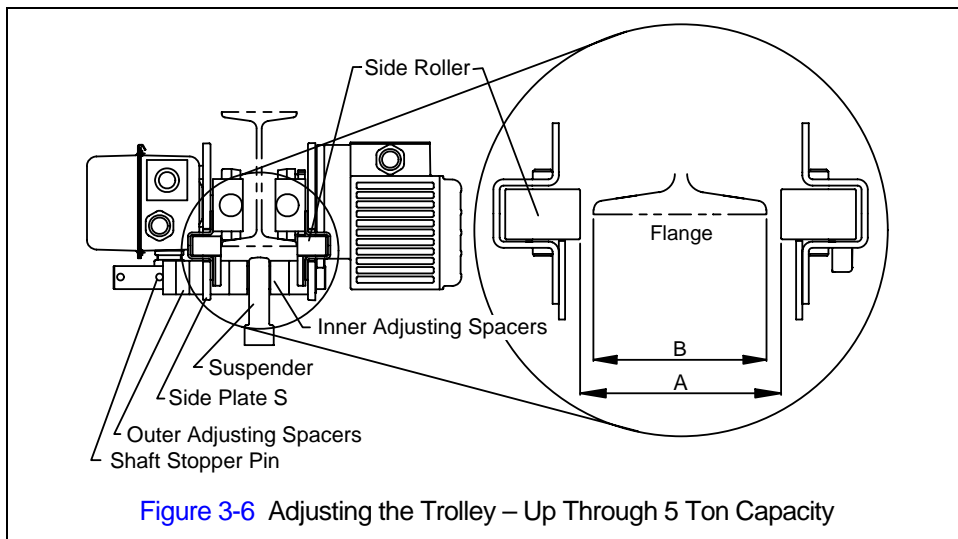


**Figure 3-3** Assembling the Trolley – Up Through 5 Ton Capacity



3.1.6 Adjusting the trolley width - After assembling trolley per [Section 3.1.5](#), check the adjustment as follows:

- 1) Refer to [Figure 3-6 or 3-7](#).
- 2) Make sure both side plates are spread fully outward and Measure Dimension "A". Compare dimension "A" with the following values:
  - For trolleys up through 5 Ton, "A" must be 1/8 to 3/16" greater than "B".
  - For trolleys 8 Ton and larger, "A" must be 7/32 to 9/32" greater than "B".
- 3) If "A" does not fall within the specified range, move spacers from inner to outer or from outer to inner as necessary to obtain the proper "A" dimension, irrespective of the numbers in [Table 3-2](#).
- 4) After obtaining the proper adjustment, install the Shaft Stopper Pin in Hole A, insert the Split Pin into the Shaft Stopper Pin, and securely bend both branches of the split pin.



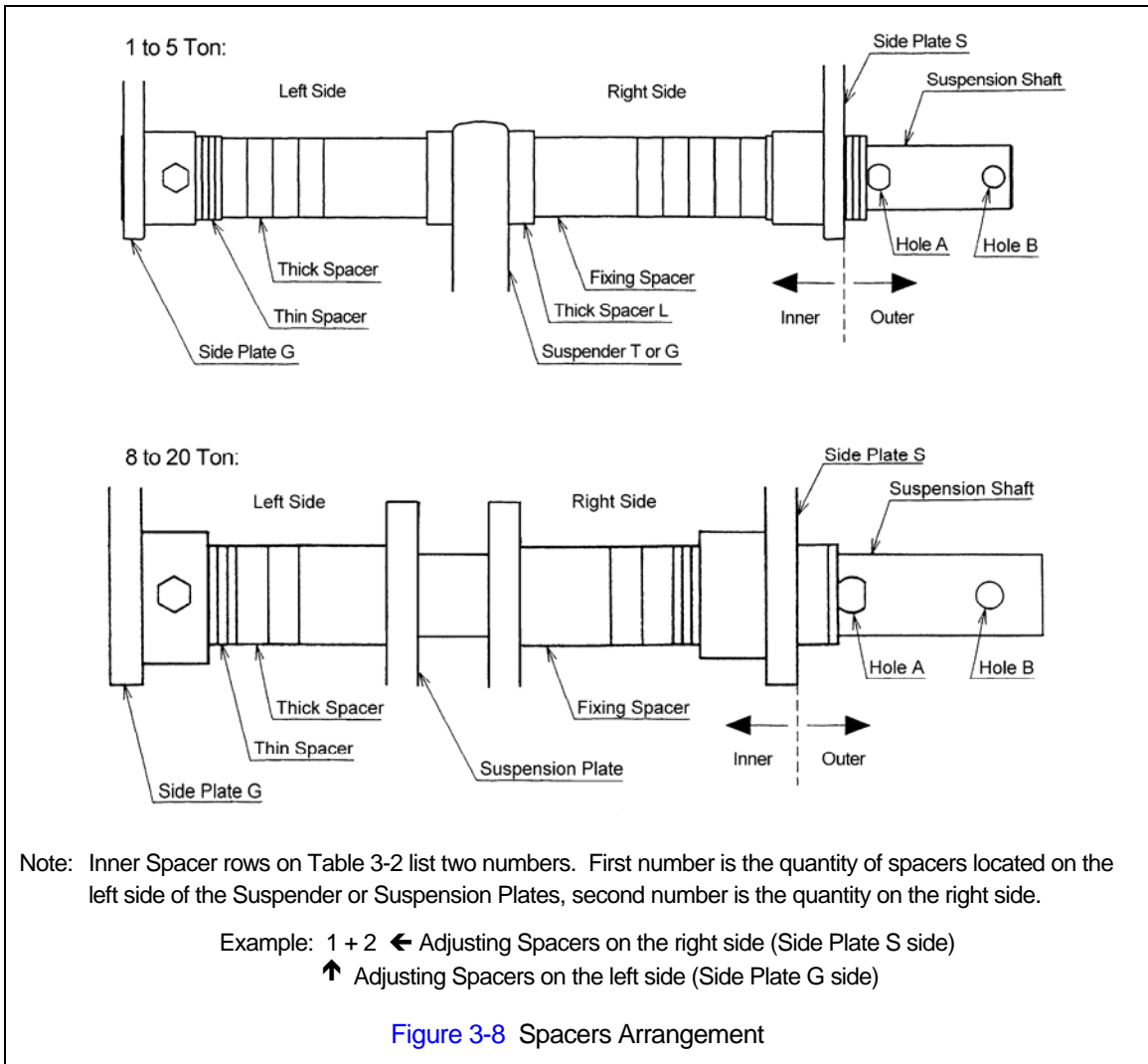


Table 3-1 Suspension Shaft Adjusting Spacers, and Suspension Shaft Bolt						
Capacity (Tons)	Flange Range (in)	Total Number of Spacers Supplied				Suspension Shaft Bolt Location
		Thin	Thick	Fixing	Thick L	
1	2.28 to 5.00	8	3	—	2	Hole 2
	5.01 to 6.02	8	5	—	2	Hole 1
	6.03 to 12.00	8	9	2	2	Hole 1
2 & 3	3.23 to 6.02	8	3	—	2	Hole 2
	6.03 to 7.02	8	5	—	2	Hole 1
	7.03 to 12.00	8	9	2	2	Hole 1
5	3.94 to 7.01	8	3	—	2	Hole 2
	7.02 to 7.60	8	4	—	2	Hole 1
	7.61 to 12.00	8	13	—	2	Hole 1
8 and up	5.91 to 8.66	8	6	—	—	Hole 1
	8.67 to 12.00	8	7	2	—	Hole 1



**Table 3-2 Number of Adjusting Spacers**

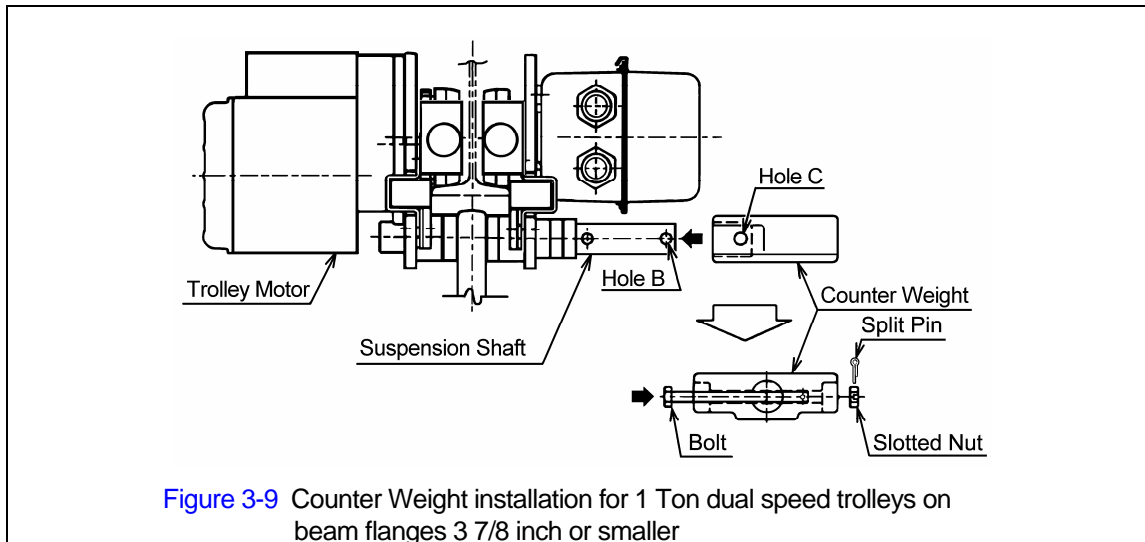
Beam Flange Width (in)	Cap. (Ton)	Spacer Type (mm)	2 5/16	2 1/2	2 7/8	3	3 1/4	3 9/16	3 7/8	3 15/16	4	4 3/16	4 5/16	4 7/16	4 11/16	4 15/16	5	5 3/16	5 5/16	5 3/8	5 5/8	5 7/8	6	6 1/8	6 5/16	6 7/16	6 11/16	6 7/8	7	
			2 5/8	2 15/16	75	82	90	98	100	102	106	110	113	119	125	127	131	135	137	143	149	153	155	160	163	170	175	178		
			58	64	73	75	82	90	98	100	102	106	110	113	119	125	127	131	135	137	143	149	153	155	160	163	170	175	178	
			66	74	76	82	91	98	100	102	106	110	113	119	125	127	131	135	137	143	149	153	155	160	163	170	175	178		
1	Thin	Inner	1+2	2+3	4+4	1+0	1+2	2+3	0	1+0	1+0	1+2	2+2	2+3	3+4	4+4	4+1	5+1	2+2	2+2	3+3	4+4	4+1	1+1	2+2	2+3	3+0	4+4	4+1	
		Outer	5	3	0	7	5	3	8	7	7	5	4	3	1	0	3	2	4	4	2	0	3	6	4	3	5	0	3	
	Thick	Inner	0+0	0+0	0+0	0+0	0+0	0+0	1+1	1+1	1+1	1+1	1+1	1+1	1+1	1+1	1+2	1+2	2+2	2+2	2+2	2+2	2+2	2+2	3+3	3+3	3+3	3+4	3+3	3+4
		Outer	3	3	3	3	3	3	1	1	1	1	1	1	1	1	0	2	1	1	1	1	1	3	3	3	2	3	2	
	Fixing	Inner	—	—	—	—	—	—	—	—	—	—	—	—	—	—	—	—	—	—	—	—	—	—	—	—	—	—	—	—
		Outer	—	—	—	—	—	—	—	—	—	—	—	—	—	—	—	—	—	—	—	—	—	—	—	—	—	—	—	—
	Thick L	Inner	0+0	0+0	0+0	1+1	1+1	1+1	1+1	1+1	1+1	1+1	1+1	1+1	1+1	1+1	1+1	1+1	1+1	1+1	1+1	1+1	1+1	1+1	1+1	1+1	1+1	1+1	1+1	1+1
		Outer	2	2	2	0	0	0	0	0	0	0	0	0	0	0	0	0	0	0	0	0	0	0	0	0	0	0	0	0
	2 and 3	Thin	Inner					1+2	2+3	3+4	0	1+0	1+1	1+2	2+2	3+3	4+4	1+0	1+1	1+2	2+2	3+3	4+0	4+1	1+1	1+2	2+2	3+3	4+4	1+4
			Outer					5	3	1	8	7	6	5	4	2	0	7	6	5	4	2	4	3	6	5	4	2	0	3
Thick		Inner					0+0	0+0	0+0	0+0	0+0	0+0	0+0	0+0	0+0	0+0	1+1	1+1	1+1	1+1	1+1	1+2	1+2	2+2	2+2	2+2	2+2	2+2	2+2	3+2
		Outer					3	3	3	3	3	3	3	3	3	3	1	1	1	1	1	0	0	1	1	1	1	1	0	
Fixing		Inner					—	—	—	—	—	—	—	—	—	—	—	—	—	—	—	—	—	—	—	—	—	—	—	
		Outer					—	—	—	—	—	—	—	—	—	—	—	—	—	—	—	—	—	—	—	—	—	—	—	
Thick L		Inner					0+0	0+0	0+0	1+1	1+1	1+1	1+1	1+1	1+1	1+1	1+1	1+1	1+1	1+1	1+1	1+1	1+1	1+1	1+1	1+1	1+1	1+1	1+1	
		Outer					2	2	2	0	0	0	0	0	0	0	0	0	0	0	0	0	0	0	0	0	0	0	0	
5		Thin	Inner								0+0	1+0	1+1	1+2	2+2	3+3	0	1+0	1+1	2+2	2+2	3+3	4+0	4+1	1+1	2+2	2+3	3+0	4+4	4+1
			Outer									8	7	6	5	4	2	8	7	6	4	4	2	4	3	6	4	3	5	0
	Thick	Inner									0+0	0+0	0+0	0+0	0+0	0+0	0+0	0+0	0+0	0+0	0+0	0+0	0+1	0+1	1+1	1+1	1+1	1+2	1+1	1+2
		Outer									3	3	3	3	3	3	3	3	3	3	3	2	2	1	1	1	0	1	0	
	Thick L	Inner									0+0	0+0	0+0	0+0	0+0	0+0	1+1	1+1	1+1	1+1	1+1	1+1	1+1	1+1	1+1	1+1	1+1	1+1	1+1	
		Outer									2	2	2	2	2	2	0	0	0	0	0	0	0	0	0	0	0	0	0	
8 thru 20	Thin	Inner																					1+1	1+2	1+2	2+3	3+3	4+4	1+1	1+2
		Outer																					6	5	5	3	2	0	6	5
	Thick	Inner																					1+1	1+1	1+1	1+1	1+1	1+1	2+2	2+2
		Outer																					4	4	4	4	4	4	2	2
	Fixing	Inner																					—	—	—	—	—	—	—	—
		Outer																					—	—	—	—	—	—	—	—

**Table 3-2 Number of Adjusting Spacers (continued)**

Beam Flange Width (in)		7 1/16	7 1/4	7 7/8	8	8 7/16	8 11/16	9	9 1/8	9 7/8	10	10 1/8	10 1/4	10 3/8	10 1/2	11	11 1/8	11 1/4	11 3/8	11 5/8	11 3/4	11 13/16	11 7/8	12		
		7 1/8	7 5/16																							
Cap. (Ton)	Spacer Type (mm)	180	184	200	203	215	220	229	232	250	254	257	260	264	267	279	283	286	289	295	298	300	302	305		
		181	185																							
1	Thin	Inner	1+1	1+2	4+4	5+0	2+3	3+4	1+1	1+2	4+0	1+1	1+2	2+2	2+3	3+3	1+1	1+2	2+2	2+3	3+0	4+0	4+1	4+1	4+2	
		Outer	6	5	0	3	3	1	6	5	4	6	5	4	3	2	6	5	4	3	5	4	3	3	2	
	Thick	Inner	0+0	0+0	0+0	0+1	1+1	1+1	2+2	2+2	2+3	3+3	3+3	3+3	3+3	3+3	4+4	4+4	4+4	4+4	4+5	4+5	4+5	4+5	4+5	
		Outer	9	9	9	8	7	7	5	5	4	3	3	3	3	3	1	1	1	1	0	0	0	0	0	
	Fixing	Inner	1+1	1+1	1+1	1+1	1+1	1+1	1+1	1+1	1+1	1+1	1+1	1+1	1+1	1+1	1+1	1+1	1+1	1+1	1+1	1+1	1+1	1+1	1+1	
		Outer	0	0	0	0	0	0	0	0	0	0	0	0	0	0	0	0	0	0	0	0	0	0	0	
	Thick L	Inner	1+1	1+1	1+1	1+1	1+1	1+1	1+1	1+1	1+1	1+1	1+1	1+1	1+1	1+1	1+1	1+1	1+1	1+1	1+1	1+1	1+1	1+1	1+1	
		Outer	0	0	0	0	0	0	0	0	0	0	0	0	0	0	0	0	0	0	0	0	0	0	0	
	2 and 3	Thin	Inner	1+1	1+2	4+4	1+0	2+3	3+3	4+1	1+1	4+4	4+1	5+1	4+3	2+3	3+3	4+1	1+2	2+2	2+3	3+3	3+4	4+4	4+1	5+1
			Outer	6	5	0	7	3	2	3	6	0	3	2	1	3	2	3	5	4	3	2	1	0	3	2
Thick		Inner	0+0	0+0	0+0	1+1	1+1	1+1	1+2	2+2	2+2	2+3	2+3	2+3	3+3	3+3	3+4	4+4	4+4	4+4	4+4	4+4	4+4	4+5	4+5	
		Outer	9	9	9	7	7	7	6	5	5	4	4	4	3	3	2	1	1	1	1	1	1	0	0	
Fixing		Inner	1+1	1+1	1+1	1+1	1+1	1+1	1+1	1+1	1+1	1+1	1+1	1+1	1+1	1+1	1+1	1+1	1+1	1+1	1+1	1+1	1+1	1+1	1+1	
		Outer	0	0	0	0	0	0	0	0	0	0	0	0	0	0	0	0	0	0	0	0	0	0	0	
Thick L		Inner	1+1	1+1	1+1	1+1	1+1	1+1	1+1	1+1	1+1	1+1	1+1	1+1	1+1	1+1	1+1	1+1	1+1	1+1	1+1	1+1	1+1	1+1	1+1	
		Outer	0	0	0	0	0	0	0	0	0	0	0	0	0	0	0	0	0	0	0	0	0	0	0	
5		Thin	Inner	1+0	1+1	4+4	1+0	2+3	3+4	1+1	1+2	4+4	1+1	1+2	2+2	2+3	3+3	5+1	1+2	2+2	2+3	4+3	4+4	4+0	4+1	5+1
			Outer	7	6	0	7	3	1	6	5	0	6	5	4	3	2	2	5	4	3	1	0	4	3	2
	Thick	Inner	2+2	2+2	2+2	3+3	3+3	3+3	4+4	4+4	4+4	5+5	5+5	5+5	5+5	5+5	5+6	6+6	6+6	6+6	6+6	6+6	6+7	6+7	6+7	
		Outer	0	0	9	7	7	7	5	5	5	3	3	3	3	3	2	1	1	1	1	1	0	0	0	
	Thick L	Inner	1+1	1+1	1+1	1+1	1+1	1+1	1+1	1+1	1+1	1+1	1+1	1+1	1+1	1+1	1+1	1+1	1+1	1+1	1+1	1+1	1+1	1+1	1+1	
		Outer	0	0	0	0	0	0	0	0	0	0	0	0	0	0	0	0	0	0	0	0	0	0	0	
8 thru 20	Thin	Inner	2+2	2+3	1+1	1+2	3+3	4+4	1+1	1+2	4+4	1+1	1+2	2+2	2+3	3+3	1+1	1+2	2+2	2+3	3+4	4+0	4+0	4+1	5+1	
		Outer	4	3	6	5	2	0	6	5	0	6	5	4	3	2	6	5	4	3	1	4	4	3	2	
	Thick	Inner	2+2	2+2	3+3	3+3	3+3	3+3	1+1	1+1	1+1	2+2	2+2	2+2	2+2	2+2	3+3	3+3	3+3	3+3	3+3	3+4	3+4	3+4	3+4	
		Outer	2	2	0	0	0	0	5	5	5	3	3	3	3	3	1	1	1	1	1	0	0	0	0	
	Fixing	Inner	—	—	—	—	—	—	1+1	1+1	1+1	1+1	1+1	1+1	1+1	1+1	1+1	1+1	1+1	1+1	1+1	1+1	1+1	1+1	1+1	
		Outer	—	—	—	—	—	—	0	0	0	0	0	0	0	0	0	0	0	0	0	0	0	0	0	



- 3.1.7 Counter Weight – For proper balance 1 Ton, dual speed MR trolleys (code MR010SD) require a Counter Weight when installed on a 3 7/8 inch or smaller beam flange. The Counter Weight mounts on the Suspension Shaft as shown in [Figure 3-9](#) and is held in place with a Bolt, Slotted Nut and Split Pin. The bolt is installed through holes B and C. Make sure the weight is securely fastened to the shaft and that the split pin is properly bent. All other trolley capacities do NOT require a counter weight.



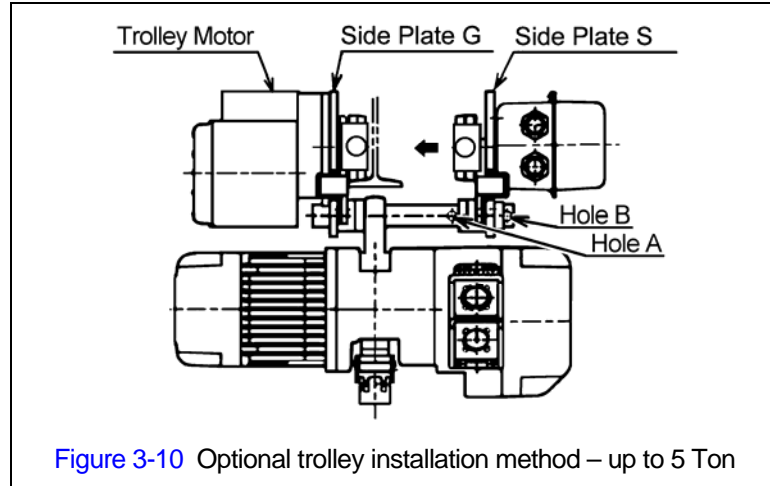
## 3.2 Mounting Location

- 3.2.1 **⚠ WARNING** Prior to mounting the trolley (and hoist) ensure that the trolley beam and its supporting structure are adequate to support the trolley, hoist and its loads. If necessary consult a professional that is qualified to evaluate the adequacy of the suspension location and its supporting structure.

- 3.2.2 **NOTICE** See [Section 6.4](#) for outdoor installation considerations.

## 3.3 Installation of Trolley onto Beam

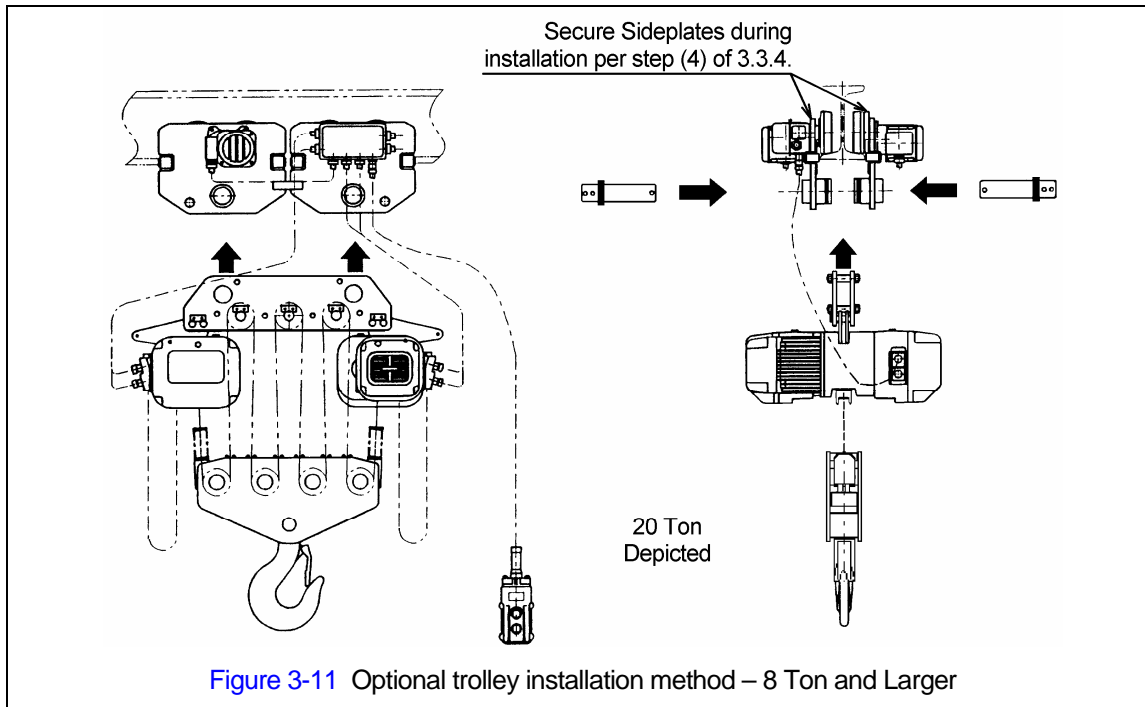
- 3.3.1 Assemble and adjust the trolley before attempting to install the trolley on the beam.
- 3.3.2 Preferred Method – Sliding the trolley connected with an electric chain hoist onto the traversing beam from the beam end is the most convenient and recommended method. If the trolley can be mounted from the end of the beam then: Remove the trolley end-stop from the beam and set the trolley on the beam from the end. Securely re-install the trolley end stop on the beam.
- 3.3.3 Optional Method for Trolleys Up to 5 Ton – If the trolley cannot be mounted from the end of the beam, complete the installation as follows:
- 1) Move the Shaft Stopper Pin to Hole B (see [Figure 3-10](#)).
  - 2) Spread the trolley side plates apart.
  - 3) Lift the trolley onto the beam so that the geared wheels (motor side of trolley) rest on the beam's flange.
  - 4) Hold Side Plate G securely so that it does not come off the beam then push the side plates together so that all four wheels rest on the beam's flange.
  - 5) Remove the Shaft Stopper Pin from Hole B and re-install in Hole A (see [Figure 3-5](#)). Bend the Split Pin securely. Never use trolley with Shaft Stopper Pin in Hole B. Hole B is ONLY used when installing the trolley on the beam.



3.3.4 Optional Method for 8 to 20 Ton Trolley with hoist - refer to [Figure 3-11](#).

**⚠ WARNING** ALWAYS install the trolley onto the beam before installing the hoist to the trolley. Attempting to install a pre-assembled hoist and trolley onto the beam other than onto the beam end (per [Section 3.3.2](#)) is dangerous and must not be attempted.

- 1) Assemble and adjust the trolley.
- 2) Separate the trolley from the hoist by removing the Suspension Shaft(s), Adjusting spacers and Trolley Fixing Shaft (8 and 10 Ton only). Reassemble the trolley without the hoist by reinstalling the Suspension Shaft(s), Trolley Fixing Shaft and outer Adjusting Spacers. Place inner spacers aside until step (6).
- 3) Install the trolley on the beam by following steps (1) to (5) of [Section 3.3.3](#).
- 4) Use safe and proper rigging practices to secure the trolley side plates so that they will remain firmly in place after the Suspension Shaft(s) and Trolley Fixing Shaft are removed (next step).
- 5) Remove the Suspension Shaft(s), Trolley Fixing Shaft and outer Adjusting Spacers.
- 6) Move the hoist up into position between the trolley side plates and line up the trolley and hoist's Suspension Shaft holes.
- 7) Connect the hoist to the trolley by reinstalling the Suspension Shaft(s), Trolley Fixing Shaft, Adjusting Spacers, Suspension Shaft Bolt(s), and Shaft Stopper Pin(s).
- 8) Ensure that:
  - Shaft Stopper Pin(s) is(are) in hole A of the Suspension Shaft(s).
  - Split Pins are installed properly.
  - Trolley is properly adjusted (refer to [Section 3.1.6](#)).



### 3.4 Electrical Connections

- 3.4.1 **⚠ CAUTION** Ensure that the voltage of the electric power supply is proper for the hoist or trolley.
- 3.4.2 **⚠ CAUTION** Do NOT apply electronic soft-start control or voltage varying controls to the MR trolley. Use of such devices may cause the motor brake and other electrical components to malfunction. Variable frequency drives MAY be used with MR trolleys, contact Harrington for more information.
- 3.4.3 **⚠ DANGER** Before proceeding, ensure that the electrical supply for the hoist or trolley has been de-energized (disconnected). Lock out and tag out in accordance with ANSI Z244.1 “Personnel Protection -Lockout/Tagout of Energy Sources”.
- 3.4.4 This instruction applies to installations where an ER or NER model electric hoist is installed on an MR trolley. In this case the hoist and trolley are controlled by a pendant with four push buttons – two for the hoist motion and two for the trolley motion. Special wiring considerations must be taken if the trolley is used with a hoist other than an ER or NER model.

**Pendant Cord** - The Pendant Cord connects to the trolley via an 8-pin (8P) Plug and Socket. Make this connection as follows:

- 1) Refer to [Figure 3-12](#) or [3-13](#) depending on the product code of the trolley/hoist.
- 2) Insert the 8P Plug into the 8P Socket on the Switch Box and hand tighten the Screw Coupling.
- 3) For trolley/hoist code ERM001H to ERM100L – Install the Cord Strain Relief Cable to the Cord Support on the Bar Holder.
- 4) For trolley/hoist code ERM100S – install the Cord Strain Relief Cable onto Cord Strain Relief Stopper located at the 8P socket.
- 5) For trolley/hoist code ERM150S and ERM200S – Install the Cord Strain Relief Cable onto Connection Plate S.

**Power Supply Cable Hoist Connection** – The Power Supply Cable connects directly to the trolley's Switch Box using Cable Holder Assembly. Make this connection as follows:

- 1) Refer to [Figure 3-12 or 3-13](#) depending on the product code of the trolley/hoist.
- 2) With 1 inch of the outer cable insulation extending beyond the cable packing, insert the cable into the switch box and screw together Cable Holder A and B.
- 3) Refer to [Figure 3-14](#) and connect the black, red and white wires to terminals 1, 2, and 3 on the terminal strip inside the Switch Box. Connect the ground wire (green with yellow stripe or solid green) to the ground terminal next to the terminal strip.
- 4) Install the Cable Support Assembly (pre-installed on the Power Supply Cable) onto the Cable Support Arm Assembly as shown in [Figure 3-15](#).
- 5) Use care to avoid twisting or kinking the Power Supply Cable.

**Trolley to Hoist Connections** – The trolley connects to the hoist via short cables that are factory installed into the trolley Switch Box. The Cables are fitted with plug assemblies that match sockets in the hoist bodies. Make these connections as follows:

- 1) Refer to [Figure 3-12 or 3-13](#) depending on the product code of the trolley/hoist.
- 2) Insert the 4P Plug(s) into the 4P Socket(s) on the hoist and hand tighten the Screw Coupling(s).
- 3) Insert the 5P Plug(s) into the 5P Socket(s) on the hoist and hand tighten the Screw Coupling(s).

**Power Supply Cable Festooning** – The MR trolley is standardly supplied with Cable Hangers for the Power Supply Cable. Make this connection as follows:

- 1) Refer to [Figure 3-15](#).
- 2) Install the Cable Hangers onto the Power Supply Cable spacing them every 5 feet.
- 3) Install a Guide Wire system parallel to the beam. Pass the Guide Wire through the Cable Hangers and Wire Guide.
- 4) Make sure the Guide Wire is properly tensioned and the Power Supply Cable is not twisted or kinked.

3.4.5 Connection to Electrical Power Source - The black, red and white wires of the Power Supply Cable should be connected to an Electric Power Disconnect Switch or Circuit Breaker. This connection should be made so that the ER, NER or other hoist is phased properly. Refer to [Section 3.5.5](#) for instructions on how to check for correct power supply phase connection.

3.4.6 Fuse/Breaker Capacity -The power supply for the trolley and hoist should be equipped with overcurrent protection such as fuses, which should be selected for 110% to 120% of total listed full load amperage, and should be dual element time-delay fuses. Refer to the motor nameplates on the trolley and hoist for the full load amperage draw of each and added the two values together for the total amperage.

3.4.7 **⚠ DANGER** Grounding - An improper or insufficient ground connection creates an electrical shock hazard when touching any part of the hoist or trolley. In the Power Supply Cable the ground wire will be either Green with Yellow stripe or solid Green. It should always be connected to a suitable ground connection. Do not paint the trolley wheel running surfaces of the beam as this can affect grounding.

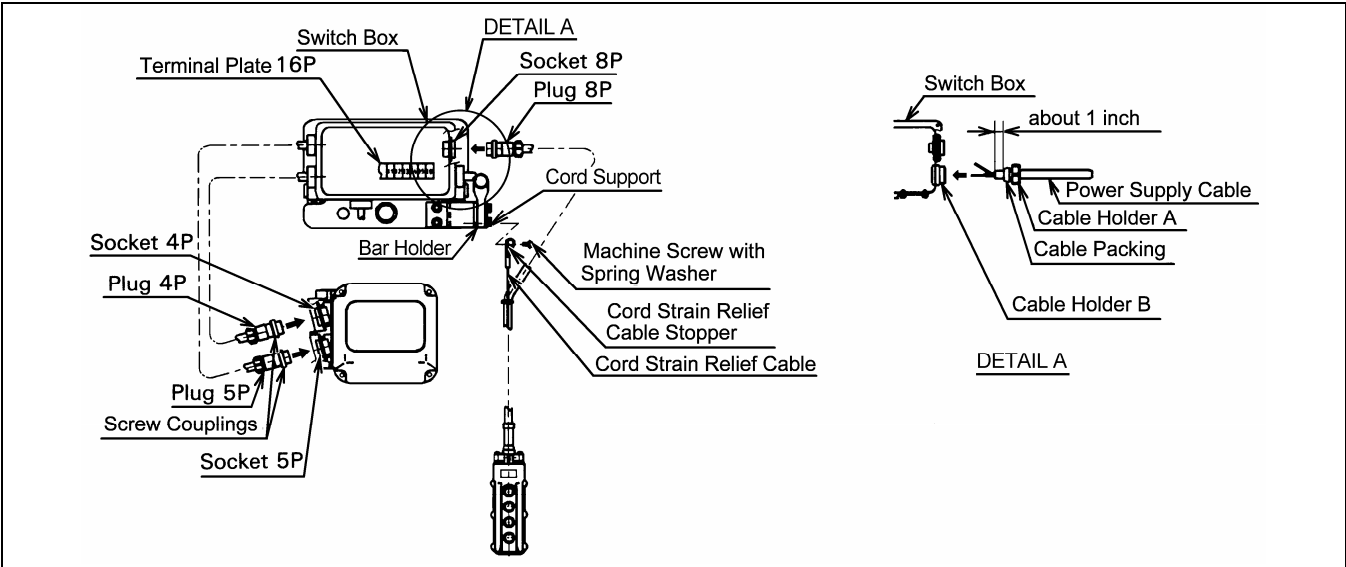


Figure 3-12 Pendant and Power Supply Cable Connection – Product Code ERM001H to ERM100L

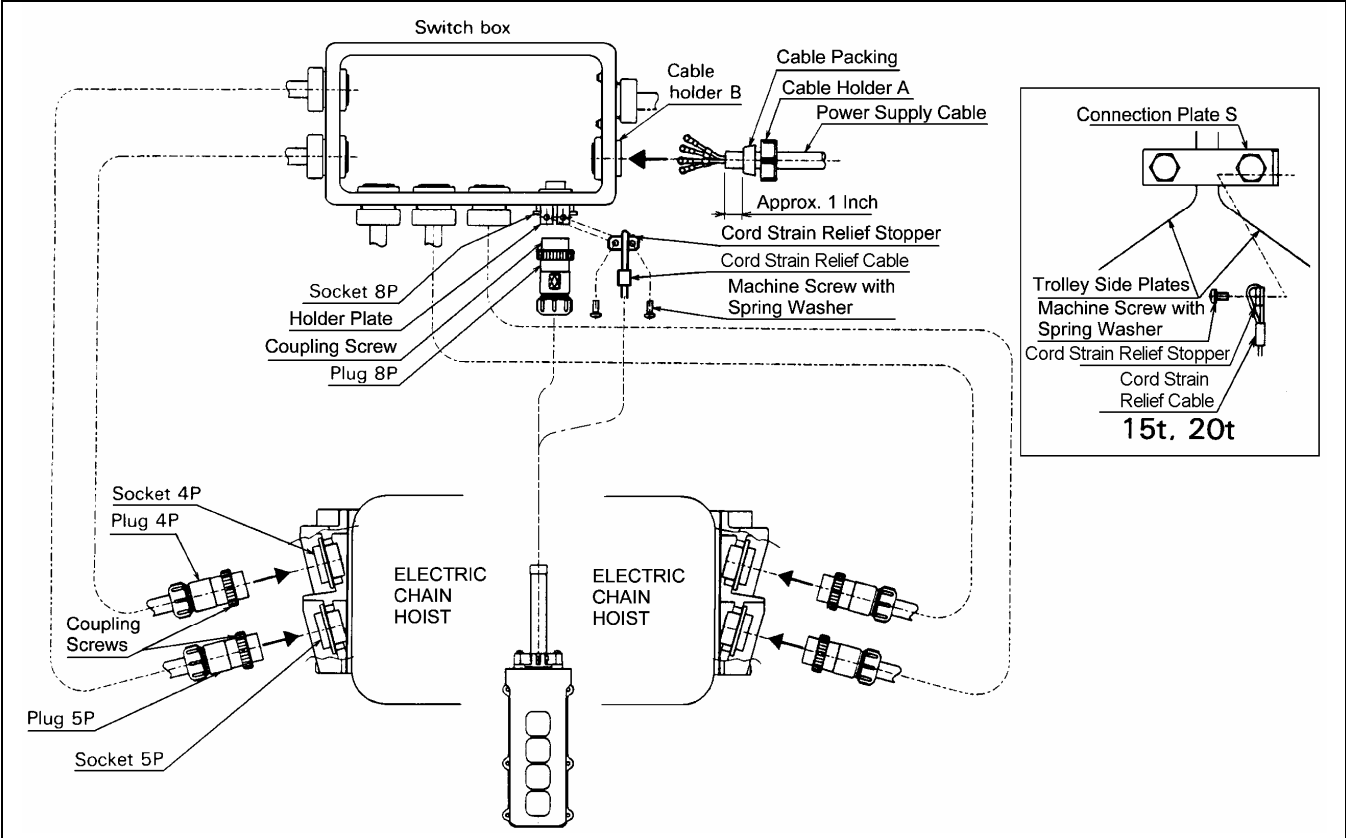
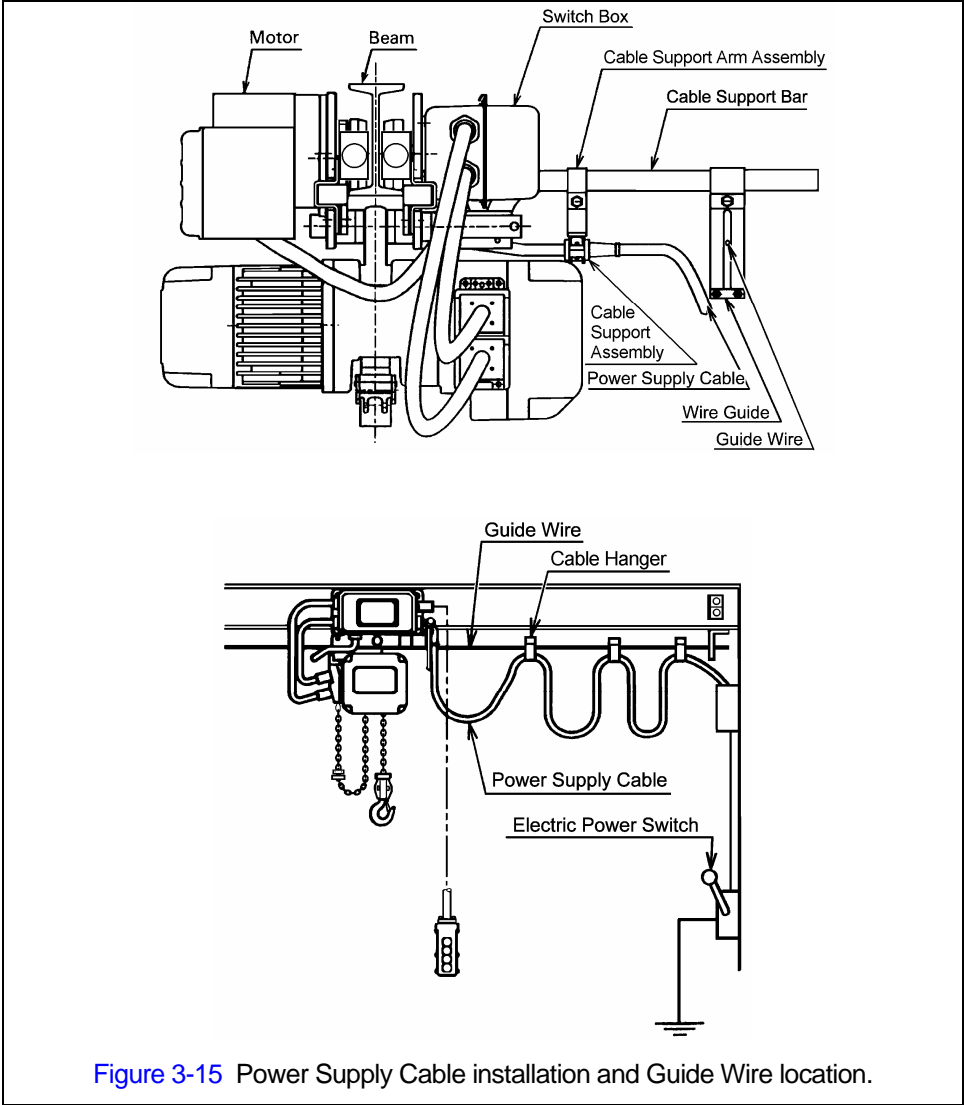
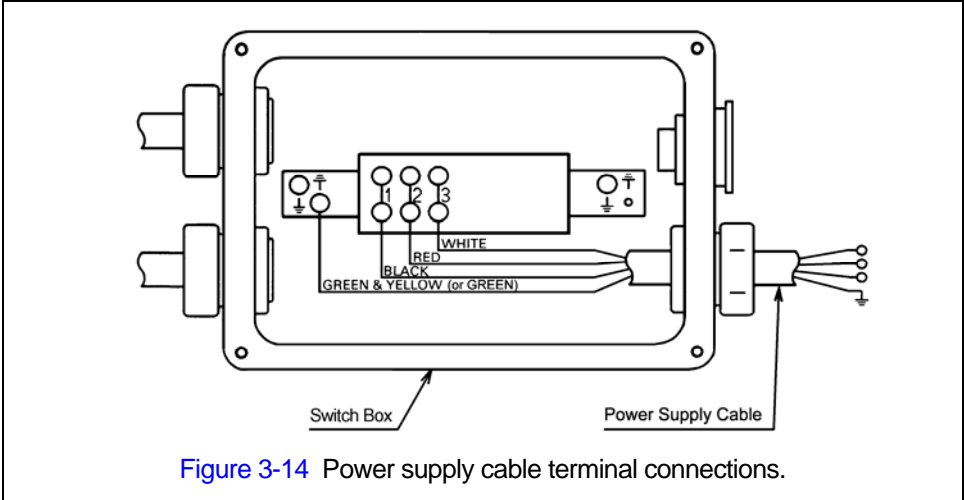


Figure 3-13 Pendant and Power Supply Cable Connection - Product Code ERM100S to ERM200S



## 3.5 Pre-operational Checks and Trial Operation

3.5.1 Refer to the trolley's Nameplate and record the Code, Lot and Serial Number in the space provided on the cover of this manual.

3.5.2 Refer to the hoist's owner's manual and perform all pre-operational checks for the hoist.

3.5.3 Perform pre-operational checks for the trolley:

- **⚠ WARNING** Confirm the adequacy of the rated capacity for all slings, chains, wire ropes and all other lifting attachments before use. Inspect all load suspension members for damage prior to use and replace or repair all damaged parts.
- Ensure that trolley is properly installed on the beam, and stops for the trolley are correctly positioned and securely installed on the beam.
- Ensure that all nuts, bolts and split pins (cotter pins) are sufficiently fastened.
- Pull down on the Pendant and ensure that the Cord Strain Relief Cable takes the force, not the Pendant Cord.
- **⚠ CAUTION** Check supply voltage before everyday use. If the voltage varies more than 10% of the rated value, electrical devices may not function normally.

3.5.4 Confirm proper operation.

- Before operating read and become familiar with [Section 4 - Operation](#).
- Before operating ensure that the hoist (and trolley) meets the Inspection, Testing and Maintenance requirements of ANSI/ASME B30.16.
- Before operating ensure that nothing will interfere with the full range of the hoist's (and trolley's) operation.

3.5.5 Proceed with trial operation to confirm proper operation.

- Verify that the controls agree with hoist direction. Make sure that depression of the Up button lifts the load chain and depression of the Down button lowers the load chain hook. If the load chain does not move in the correct direction when the push buttons are pushed, the power supply is phased incorrectly. In this case, turn off the power source or breaker switch then reverse any two of the three wires at the power source. The hook will then move in accordance with the directions of the push button.
- Operate the trolley through its full range of motion. Make sure the trolley runs smoothly and does not bind. Check the power supply and festoon system for proper operation.
- Perform inspections per [Section 5.3](#), "Frequent Inspections".

## 4.0 Operation

### 4.1 Introduction

#### **DANGER**

DO NOT WALK UNDER A SUSPENDED LOAD

#### **WARNING**

HOIST OPERATORS SHALL BE REQUIRED TO READ THE OPERATION SECTION OF THIS MANUAL, THE WARNINGS CONTAINED IN THIS MANUAL, INSTRUCTION AND WARNING LABELS ON THE HOIST OR LIFTING SYSTEM, AND THE OPERATION SECTIONS OF ANSI/ASME B30.16 and ANSI/ASME B30.10. THE OPERATOR SHALL ALSO BE REQUIRED TO BE FAMILIAR WITH THE HOIST AND HOIST CONTROLS BEFORE BEING AUTHORIZED TO OPERATE THE HOIST OR LIFTING SYSTEM.

HOIST OPERATORS SHOULD BE TRAINED IN PROPER RIGGING PROCEDURES FOR THE ATTACHMENT OF LOADS TO THE HOIST HOOK.

HOIST OPERATORS SHOULD BE TRAINED TO BE AWARE OF POTENTIAL MALFUNCTIONS OF THE EQUIPMENT THAT REQUIRE ADJUSTMENT OR REPAIR, AND TO BE INSTRUCTED TO STOP OPERATION IF SUCH MALFUNCTIONS OCCUR, AND TO IMMEDIATELY ADVISE THEIR SUPERVISOR SO CORRECTIVE ACTION CAN BE TAKEN.

HOIST OPERATORS SHOULD HAVE NORMAL DEPTH PERCEPTION, FIELD OF VISION, REACTION TIME, MANUAL DEXTERITY, AND COORDINATION.

HOIST OPERATORS SHOULD **NOT** HAVE A HISTORY OF OR BE PRONE TO SEIZURES, LOSS OF PHYSICAL CONTROL, PHYSICAL DEFECTS, OR EMOTIONAL INSTABILITY THAT COULD RESULT IN ACTIONS OF THE OPERATOR BEING A HAZARD TO THE OPERATOR OR TO OTHERS.

HOIST OPERATORS SHOULD **NOT** OPERATE A HOIST OR LIFTING SYSTEM WHEN UNDER THE INFLUENCE OF ALCOHOL, DRUGS, OR MEDICATION.

OVERHEAD HOISTS ARE INTENDED ONLY FOR VERTICAL LIFTING SERVICE OF FREELY SUSPENDED UNGUIDED LOADS. DO **NOT** USE HOIST FOR LOADS THAT ARE NOT LIFTED VERTICALLY, LOADS THAT ARE NOT FREELY SUSPENDED, OR LOADS THAT ARE GUIDED.

#### **NOTICE**

- Read ANSI/ASME B30.16 and ANSI/ASME B30.10.
- Read the hoist manufacturer's Operating and Maintenance Instructions.
- Read all labels attached to equipment.

The operation of an overhead hoist involves more than activating the hoist's controls. Per the ANSI/ASME B30 standards, the use of an overhead hoist is subject to certain hazards that cannot be mitigated by engineered features, but only by the exercise of intelligence, care, common sense, and experience in anticipating the effects and results of activating the hoist's controls. Use this guidance in conjunction with other warnings, cautions, and notices in this manual to govern the operation and use of your overhead hoist.

## 4.2 Shall's and Shall Not's for Operation

### **WARNING**

Improper operation of a hoist can create a potentially hazardous situation which, if not avoided, could result in death or serious injury, and substantial property damage. To avoid such a potentially hazardous situation **THE OPERATOR SHALL:**

- **NOT** lift more than rated load for the hoist.
- **NOT** operate unless load is centered under hoist.
- **NOT** use damaged hoist or hoist that is not working properly.
- **NOT** use hoist with twisted, kinked, damaged, or worn chain.
- **NOT** use hoist if the bottom hook is capsized (double fall hoists - see [Section 3.2](#)).
- **NOT** use the hoist to lift, support, or transport people.
- **NOT** lift loads over people.
- **NOT** apply load unless load chain is properly seated in the load sheave (and idle sheave for hoist with two chain falls).
- **NOT** use the hoist in such a way that could result in shock or impact loads being applied to the hoist.
- **NOT** attempt to lengthen the load chain or repair damaged load chain.
- **NOT** operate hoist when it is restricted from forming a straight line from hook to hook in the direction of loading.
- **NOT** use load chain as a sling or wrap load chain around load.
- **NOT** apply the load to the tip of the hook or to the hook latch.
- **NOT** apply load if binding prevents equal loading on all load-supporting chains.
- **NOT** operate beyond the limits of the load chain travel.
- **NOT** operate hoist with missing/damaged chain springs, cushion rubbers, stoppers or striker plates.
- **NOT** leave load supported by the hoist unattended unless specific precautions have been taken.
- **NOT** allow the chain, or hook to be used as an electrical or welding ground.
- **NOT** allow the chain, or hook to be touched by a live welding electrode.
- **NOT** remove or obscure the warnings on the hoist.
- **NOT** operate a hoist on which the safety placards or decals are missing or illegible.
- Be familiar with operating controls, procedures, and warnings.
- Make sure the unit is securely attached to a suitable support before applying load.
- Make sure load slings or other approved single attachments are properly sized, rigged, and seated in the hook saddle.
- Take up slack carefully - make sure load is balanced and load-holding action is secure before continuing.
- Make sure all persons stay clear of the supported load.
- Protect the hoist's load chain from weld splatter or other damaging contaminants.
- Report Malfunctions or unusual performances (including unusual noises) of the hoist and remove the hoist from service until the malfunction or unusual performance is resolved.
- Make sure hoist limit switches function properly.
- Warn personnel before lifting or moving a load.
- Warn personnel of an approaching load.

## **⚠ CAUTION**

Improper operation of a hoist can create a potentially hazardous situation which, if not avoided, could result in minor or moderate injury, or property damage. To avoid such a potentially hazardous situation **THE OPERATOR SHALL:**

- Maintain a firm footing or be otherwise secured when operating the hoist.
- Check brake function by tensioning the hoist prior to each lift operation.
- Use hook latches. Latches are to retain slings, chains, etc. under slack conditions only.
- Make sure the hook latches are closed and not supporting any parts of the load.
- Make sure the load is free to move and will clear all obstructions.
- Avoid swinging the load or hook.
- Make sure hook travel is in the same direction as shown on controls.
- Inspect the hoist regularly, replace damaged or worn parts, and keep appropriate records of maintenance.
- Use the hoist manufacturer's recommended parts when repairing the unit.
- Lubricate load chain per hoist manufacturer's recommendations.
- **NOT** use the hoist load limiting or warning device to measure load.
- **NOT** use limit switches as routine operating stops. They are emergency devices only.
- **NOT** allow your attention to be diverted from operating the hoist.
- **NOT** allow the hoist to be subjected to sharp contact with other hoists, structures, or objects through misuse.
- **NOT** adjust or repair the hoist unless qualified to perform such adjustments or repairs.

### 4.3 Trolley and Hoist Controls

4.3.1 Single Speed Pendant Control - When using the pendant control depress the Up button to raise the hoist's hook or the Down button to lower the hoist's hook as shown in Figure 4-1. Depress the Forward and Reverse buttons to move the trolley horizontally. To stop motion release the buttons.

4.3.2 Dual Speed Pendant Control – Pendant controls supplied with dual speed hoists or trolleys have two step control buttons. For low speed depress the button to the first step and for high speed depress the button fully to the second step. Use the Up button to raise the hoist's hook or the Down button to lower the hoist's hook as shown in Figure 4-1. Depress the Forward and Reverse buttons to move the trolley horizontally. To stop motion release the buttons.

4.3.3 Trolley with Two Button Pendant – When a motorized trolley is supplied with a two button pendant, the pendant buttons control the trolley's horizontal motion in the forward and reverse directions. Single and dual speed buttons function identical to the four button pendant described above.

4.3.4 **⚠ CAUTION** Make sure the motor completely stops before reversing direction.

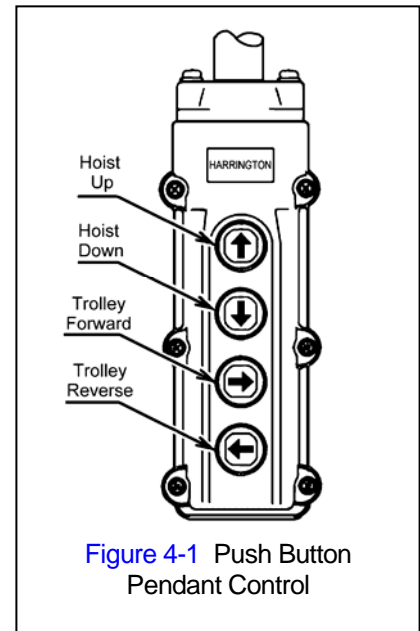


Figure 4-1 Push Button Pendant Control

## 5.0 Inspection

### 5.1 General

- 5.1.1 The inspection procedure herein is based on ANSI/ASME B30.16. The following definitions are from ANSI/ASME B30.16 and pertain to the inspection procedure below.
- **Designated Person** - a person selected or assigned as being competent to perform the specific duties to which he/she is assigned.
  - **Qualified Person** - a person who, by possession of a recognized degree or certificate of professional standing, or who, by extensive knowledge, training, and experience, has successfully demonstrated the ability to solve or resolve problems relating to the subject matter and work.
  - **Normal Service** - that distributed service which involves operation with randomly distributed loads within the rated load limit, or uniform loads less than 65% of rated load for not more than 25% of the time.
  - **Heavy Service** - that service which involves operation within the rated load limit which exceeds normal service.
  - **Severe Service** - that service which involves normal or heavy service with abnormal operating conditions.

### 5.2 Inspection Classification

- 5.2.1 Initial Inspection - prior to initial use, all new, re-installed, altered, or modified trolleys shall be inspected by a designated person to ensure compliance with the applicable provisions of this manual.
- 5.2.2 Inspection Classification - the inspection procedure for trolleys in regular service is divided into two general classifications based upon the intervals at which inspection should be performed. The intervals in turn are dependent upon the nature of the critical components of the trolley and the degree of their exposure to wear, deterioration, or malfunction. The two general classifications are herein designated as FREQUENT and PERIODIC, with respective intervals between inspections as defined below.
- 5.2.3 FREQUENT Inspection - visual examinations by the operator or other designated personnel with intervals per the following criteria:
- Normal service - monthly
  - Heavy service - weekly to monthly
  - Severe service - daily to weekly
  - Special or infrequent service - as recommended by a qualified person before and after each occurrence.
- 5.2.4 PERIODIC Inspection - visual inspection by a designated person with intervals per the following criteria:
- Normal service - yearly
  - Heavy service - semiannually
  - Severe service – quarterly
  - Special or infrequent service - as recommended by a qualified person before the first such occurrence and as directed by the qualified person for any subsequent occurrences.

### 5.3 Frequent Inspection

5.3.1 Inspections should be made on a FREQUENT basis in accordance with [Table 5-1](#), “Frequent Inspection.” Included in these FREQUENT Inspections are observations made during operation for any defects or damage that might appear between Periodic Inspections. Evaluation and resolution of the results of FREQUENT Inspections shall be made by a designated person such that the trolley is maintained in safe working condition.

<b>Table 5-1 Frequent Inspection</b>
All functional operating mechanisms for proper operation, proper adjustment, and unusual sounds.
Trolley braking system for proper operation
Hoist(s) in accordance with ANSI/ASME B30.16
Upper Limit Devices in accordance with ANSI/ASME B30.16
Hook(s) and hook latches in accordance with ANSI/ASME B30.10

### 5.4 Periodic Inspection

5.4.1 Inspections should be made on a PERIODIC basis in accordance with [Table 5-2](#), “Periodic Inspection.” Evaluation and resolution of the results of PERIODIC Inspections shall be made by a designated person such that the trolley is maintained in safe working condition.

5.4.2 For inspections where load suspension parts of the trolley are disassembled, a load test per ANSI/ASME B30.16 must be performed on the trolley [after](#) it is re-assembled and prior to its return to service.

<b>Table 5-2 Periodic Inspection</b>
Requirements of frequent inspection.
Loose or missing bolts, nuts, pins or rivets.
Worn, cracked, or distorted parts such as pins, bearings, wheels, shafts, gears, rollers, yokes, and bumpers.
Excessive wear of brake system parts
Deterioration of electrical components such as controllers, switches, contacts, pushbuttons.
Proper function of motion limit devices that interrupt power or cause a warning to be activated.
Function, instruction and warning labels for legibility and placement.

### 5.5 Occasionally Used Trolleys

5.5.1 Trolleys that are used infrequently shall be inspected as follows prior to placing in service:

- Trolley Idle More Than 1 Month, Less Than 1 Year: Inspect per FREQUENT Inspection criteria in [Section 5.3](#).
- Trolley Idle More Than 1 Year: Inspect per PERIODIC Inspection criteria in [Section 5.4](#)

### 5.6 Inspection Records

5.6.1 Dated inspection reports and records should be maintained at time intervals corresponding to those that apply for the hoist’s PERIODIC interval per [Section 5.2.4](#). These records should be stored where they are available to personnel involved with the inspection, maintenance, or operation of the trolley.

## 5.7 Inspection Methods and Criteria

5.7.1 This section covers the inspection of specific items. The list of items in this section is based on those listed in ANSI/ASME B30.16 for Frequent and Periodic Inspection. In accordance with ANSI/ASME B30.16, these inspections are not intended to involve disassembly of the trolley. Rather, disassembly for further inspection would be required if frequent or periodic inspection results so indicate. Such disassembly and further inspection should only be performed by a qualified person trained in the disassembly and re-assembly of the trolley.

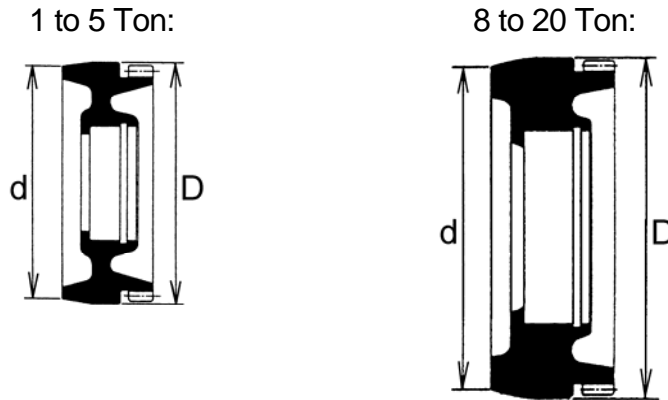
**Table 5-3 Trolley Inspection Methods and Criteria**

Item	Method	Criteria	Action
Functional operating mechanisms.	Visual, Auditory	Mechanisms should be properly adjusted and should not produce unusual sounds when operated.	Repair or replace as required.
Braking System Operation	Function	Trolley must come to a smooth stop within 10% of its traveling speed when the pendant button is released.	Repair or replace as required.
Housing and Mechanical Components	Visual, Auditory, Vibration, Function	Trolley components including, suspension shafts, track wheels, track wheel axles, clevises, connection yokes, suspension bolts, shafts, gears, bearings, pins, rollers, and bumpers should be free of cracks, distortion, significant wear and corrosion. Evidence of same can be detected visually or via detection of unusual sounds or vibration during operation.	Replace.
Side Plates	Visual	Must be free of significant deformation	Replace.
Bolts, Nuts, Snap Rings, and Split Pins	Visual, Check with Proper Tool	Bolts, nuts, snap rings and split pins should not be loose.	Tighten or replace as required.
Track Wheel - Tread	Visual, Measure	Diameter of the inside and outside tread surface should not be less than the discard value shown in <a href="#">Table 5-4</a> .	Replace.
Track Wheel - Gear	Visual	Teeth should not be cracked, damaged, or excessively worn.	Replace.
Side Rollers - Wear	Visual, Measure	Diameter should not be less than the discard value shown in <a href="#">Table 5-5</a> .	Replace.
Suspension Shaft	Visual, Measure	Suspension shaft should not be bent. Diameter should not be worn by 10% or more.	Replace.
Motor Brake	Visual, Measure	Brake lining dimension "A" should not be less than discard value listed in <a href="#">Table 5-6</a> . Refer to <a href="#">Section 6.2</a> for gaining access to motor brake and inspection procedures. Braking surfaces should be clean, free of grease/oil and should not be glazed.	Replace.
Contactor Contacts	Visual	Contacts should be free of significant pitting or deterioration.	Replace

**Table 5-3 Trolley Inspection Methods and Criteria**

Item	Method	Criteria	Action
Pendant - Switches	Function	Depressing and releasing push buttons should make and break contacts in switch contact block and result in corresponding electrical continuity or open circuit. Push-buttons should be interlocked either mechanically or electrically to prevent simultaneous energization of circuits for opposing motions (e.g. forward and reverse).	Repair or replace as necessary.
Pendant - Housing	Visual	Pendant housing should be free of cracks and mating surfaces of parts should seal without gaps.	Replace.
Pendant - Wiring	Visual	Wire connections to switches in pendant should not be loose or damaged.	Tighten or repair
Pendant And Power Cords	Visual, Electrical Continuity	Surface of cord should be free from nicks, gouges, and abrasions. Each conductor in cord should have 100% electrical continuity even when cord is flexed back-and-forth. Pendant Cord Strain Relief Cable should absorb all of the load associated with forces applied to the pendant.	Replace.
Electrical Plugs, Sockets and Fittings	Visual	Electrical Plugs, Sockets and Fittings should not be cracked or damaged.	Repair or replace as necessary.
Cable Hangers	Visual	Cable Hangers should not be damaged or significantly worn. Movement should be smooth and should not cause the Power Supply Cable to twist or kink.	Repair or replace as necessary.
Pendant - Labels	Visual	Labels denoting functions should be legible.	Replace.
Warning Labels	Visual	Warning Labels should be affixed to the pendant cord (see <a href="#">Section 1.2</a> ) and they should be legible.	Replace.
Trolley Capacity Label	Visual	The label that indicates the capacity of the trolley should be legible and securely attached to the trolley.	Replace.

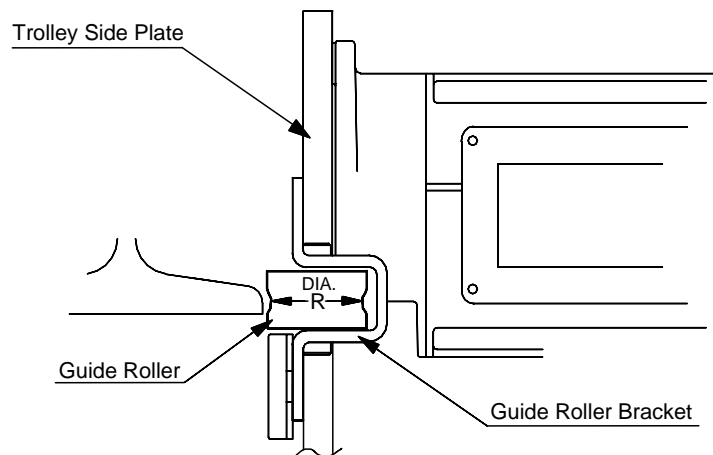
**Table 5-4 Track Wheel Wear Dimensions**



Note: Track wheels are for flat and tapered flanges.

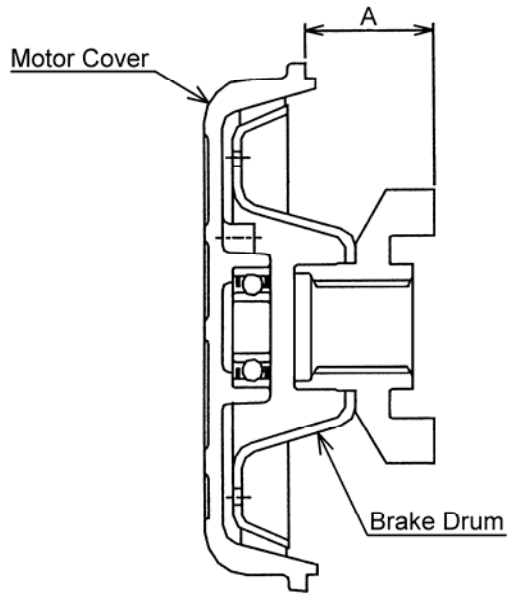
Capacity (Ton)	"d" Dimension inch (mm)		"D" Dimension inch (mm)	
	Standard	Discard	Standard	Discard
1	3.60 (91.5)	3.44 (87.5)	3.74 (95)	3.58 (91)
2	4.17 (106)	3.98 (101)	4.33 (110)	4.13 (105)
3	4.76 (121)	4.49 (114)	4.92 (125)	4.65 (118)
5	5.31 (135)	5.00 (127)	5.51 (140)	5.20 (132)
8 to 20	6.34 (166)	6.14 (156)	6.89 (175)	6.50 (165)

**Table 5-5 Side Roller Wear Dimensions**



Capacity (Ton)	"R" Dimension inch (mm)	
	Standard	Discard
1	1.50 (38)	1.46 (37)
2 and 3	1.69 (43)	1.65 (42)
5 to 20	2.17 (55)	2.13 (54)

**Table 5-6 Motor Brake Wear Dimensions**



Capacity (Ton)	"A" Dimension - inch (mm)			
	Single Speed		Dual Speed	
	Standard	Discard	Standard	Discard
1 and 2	1.28 (32.5)	1.22 (31.0)	1.45 (36.8)	1.43 (36.3)
3 to 20	1.28 (32.5)	1.22 (31.0)	1.45 (36.8)	1.41 (35.8)

## 6.0 Maintenance & Handling

### 6.1 Lubrication

- 6.1.1 Lubricate the following trolley components with NLGI (National Lubricating Grease Institute) #2 or equivalent grease.
- 6.1.2 Track Wheel Gear – Clean and re-grease the Track Wheel gears and motor output pinion every three months (more frequently for heavier usage or severe conditions). Do not use an excessive amount of grease and avoid getting any grease on the running surfaces of the Track Wheels or the beam.
- 6.1.3 Gear Box – The reduction gearing in the motor should be cleaned and lubricated at least once per year for normal usage. Clean and lubricate the reduction gear assembly more frequently for heavier usage or severe conditions. Gain access to the gears by removing the four bolts that mount the motor assembly to the trolley Side Plate. Make sure to properly orient and reuse the neoprene gasket between the motor and Side Plate.
- 6.1.4 Suspension Pins, Bolts and Shafts – Grease at least twice per year for normal usage (more frequently for heavier usage or severe conditions).

### 6.2 Brake

- 6.2.1 The trolley motor brake is NOT adjustable.
- 6.2.2 Motor Brake Removal – Remove the four Bolts that attach the Motor Cover to the Motor Frame. Carefully remove the Motor Cover, brake components, and Stator.
- 6.2.3 Brake Lining Inspection – The brake lining is designed for a long life and should provide years of trouble-free service. If the brake lining is being inspected due to excessive trolley drift during operation (see [Section 5.7](#)), disassemble the motor brake and inspect all motor brake parts. Braking surfaces should be clean, free of grease/oil and should not be glazed. Replace the Brake Drum and/or Motor Cover if necessary. For normal inspections, the Brake Lining and Motor Cover wear should be measured as follows.
  - 1) Refer to [Table 5-6](#).
  - 2) Measure the distance "A" using calipers and a straight edge. Make sure the Brake Drum is square against the Motor Cover. Place the straight edge across the edge of the Brake Drum and measure from the straight edge to the mounting face of the Motor Cover.
  - 3) Compare the measurement with the values listed in [Table 5-6](#). Replace the Brake Drum and/or Motor Cover if the "A" measurement is smaller than the discard limit.
- 6.2.4 Motor Brake Installation - After the brake is inspected, carefully place the Stator and brake components into the Motor Frame. Be sure to reseal the Motor Cover to Motor Frame surface using a small bead of liquid (hi-temperature) sealant. Install the Motor Cover attachment bolts.

### 6.3 Storage

- 6.3.1 The storage location should be clean and dry.
- 6.3.2 Care should be take to not damage any of the electrical power cords or fittings.

### 6.4 Outdoor Installation

- 6.4.1 For trolley and hoist installations that are outdoors, the trolley and hoist should be covered and protected from the weather when not in use.
- 6.4.2 Possibility of corrosion on components of the trolley increases for installations where salt air and high humidity are present. The trolley may require more frequent lubrication. Make frequent and regular inspections of the unit's condition and operation.

## 7.0 Troubleshooting

### **WARNING**

#### **HAZARDOUS VOLTAGES ARE PRESENT IN THE TROLLEY AND IN CONNECTIONS BETWEEN COMPONENTS.**

Before performing ANY maintenance on the equipment, de-energize the supply of electricity to the equipment, and lock and tag the supply device in the de-energized position. Refer to ANSI Z244.1, "Personnel Protection – Lockout/Tagout of Energy Sources."

Only Trained and competent personnel should inspect and repair this equipment.

**Table 7-1 Troubleshooting Guide**

Symptom	Cause	Remedy
Trolley will not operate	Loss of power	Check circuit breakers, switches, fuses and connections on power lines/cable.
	Wrong voltage or frequency	Check voltage and frequency of power supply against the rating on the nameplate of the motor.
	Motor overheated and thermal overload protector has tripped	See Trouble Shooting Problem "Motor or brake overheating".
	Improper, loose, or broken wire in trolley electrical system	Shut off power supply, check wiring connections in the trolley switch box, on hoist control panel and inside push-button pendant.
	Faulty magnetic contactor	Check coil for open or short circuit. Check all connections in the control circuit. Check for open contactors. Replace as needed.
	Motor burned out	Replace motor frame/stator, shaft/rotor, and any other damaged parts.
Trolley drifts excessively when stopping	Motor brake not holding	Clean and inspect brake lining. Replace if necessary
Motor or brake overheating	Excessive duty cycle	Reduce frequency of trolley movement.
	Extreme external heating	Above an ambient temperature of 140°F, the frequency of trolley operation must be reduced to avoid overheating of the motor. Special provisions should be made to ventilate the trolley or otherwise shield it from the heat.
Trolley operates intermittently	Collectors making poor contact	Check movement of spring loaded arm, weak spring, connections, and shoe. Replace as needed.
	Contactor contacts arcing	Check for burned contacts. Replace as needed.
	Loose connection in circuit	Check all wires and terminals for bad connections. Replace as needed.
	Broken conductor in Pendant Cord	Check for intermittent continuity in each conductor the Pendant Cord. Replace entire Pendant Cord if continuity is not constant.

## 8.0 Warranty

Warranty explanation and terms.

All products sold by Harrington Hoists, Inc. are warranted to be free from defects in material and workmanship from date of shipment by Harrington for the following periods:

**Manual Hoists & Trolleys - 2 years**

**Air and Electric Powered Hoists, Trolleys, and Crane Components - 1 year**

**Spare / Replacement Parts - 1 year**

The product must be used in accordance with manufacturer's recommendations and must not have been subject to abuse, lack of maintenance, misuse, negligence, or unauthorized repairs or alterations.

Should any defect in material or workmanship occur during the above time period in any product, as determined by Harrington Hoist's inspection of the product, Harrington Hoists, Inc. agrees, at its discretion, either to replace (not including installation) or repair the part or product free of charge and deliver said item F.O.B. Harrington Hoists, Inc. place of business to customer.

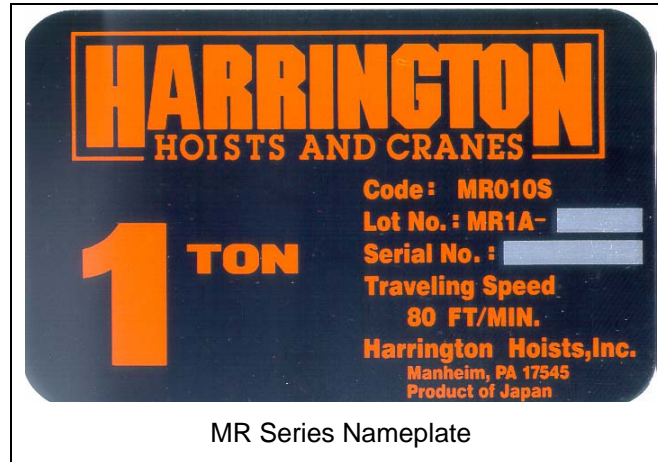
Customer must obtain a Return Goods Authorization as directed by Harrington or Harrington's published repair center prior to shipping product for warranty evaluation. An explanation of the complaint must accompany the product. Product must be returned freight prepaid. Upon repair, the product will be covered for the remainder of the original warranty period. If it is determined there is no defect, or that the defect resulted from causes not within the scope of Harrington's warranty, the customer will be responsible for the costs of returning the product.

Harrington Hoists, Inc. disclaims any and all other warranties of any kind expressed or implied as to the product's merchantability or fitness for a particular application. Harrington will not be liable for death, injuries to persons or property or for incidental, contingent, special or consequential damages, loss or expense arising in connection with the use or inability whatever, regardless of whether damage, loss or expense results from any act or failure to act by Harrington, whether negligent or willful, or from any other reason.

## 9.0 1/8 to 20 Ton Parts List

When ordering Parts, please provide the Hoist code number, lot number and serial number located on the Hoist nameplate (see fig. below).

Reminder: Per sections 1.1 and 3.5.1 to aid in ordering Parts and Product Support, record the Hoist code number, lot number and serial number in the space provided on the cover of this manual.



The parts list is arranged into the following sections:

<b>Section – 1/8 to 5 Ton</b>	<b>Page</b>
9.1 Electric Parts.....	38
9.2 Pendant Parts.....	40
9.3 Power Supply Parts.....	42
9.4 Side Plates and Suspension Parts.....	44
9.5 Motor Parts.....	46
<b>Section – 8 to 20 Ton</b>	
9.6 Motor Parts.....	48
9.7 Side Plates and Suspension Parts.....	50
9.8 Electric Parts.....	52
9.9 Electric Parts Single Speed.....	54
9.10 Electric Parts Dual Speed.....	56
9.11 Power Supply Parts.....	58
9.12 Pendant Parts.....	60
9.13 Optional Parts.....	62

In the column "Parts Per Trolley" a designator is used for parts that apply only to a particular model or option. Refer to Section 2 for MR Trolley model numbers and additional descriptions.

The designators are:

L = Single speed, Standard, 80 fpm  
 S = Single Speed, Low, 40 fpm  
 SD = Dual Speed, Standard dual, 80/20 fpm  
 SS = Single Speed (S or L)

W = SS/SS = Single Speed Hoist, Single Speed Trolley  
 X = SS/DS = Single Speed Hoist, Dual Speed Trolley  
 Y = DS/SS = Dual Speed Hoist, Single Speed Trolley  
 Z = DS/DS = Dual Speed Hoist, Dual Speed Trolley

## 9.1 Electric Parts – 1/8 to 5 Ton

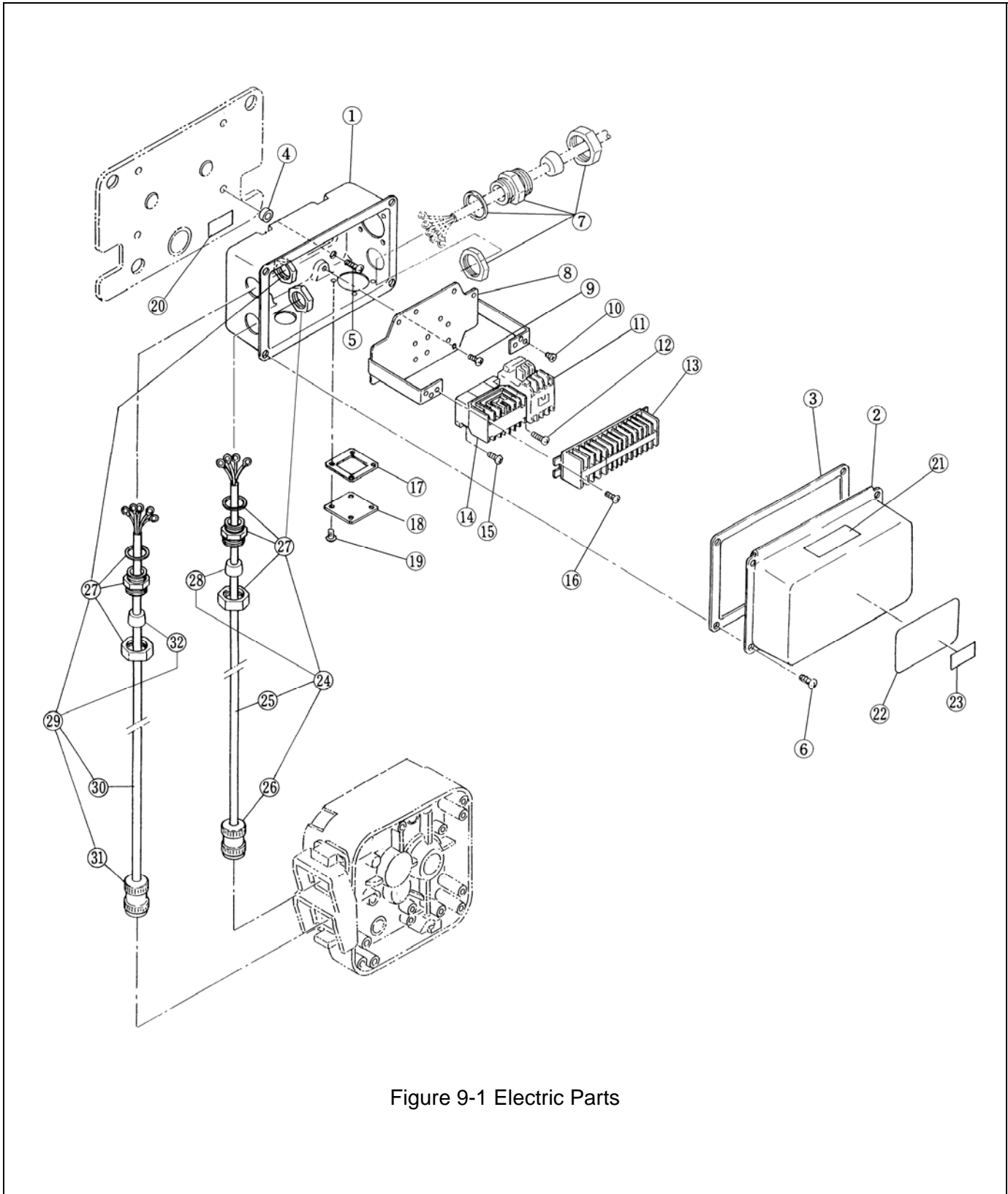


Figure 9-1 Electric Parts

## 9.1 Electric Parts – 1/8 to 5 Ton

Figure No.	Part Name	Parts Per Trolley		1 Ton	2 Ton	3 Ton	5 Ton
1	Connection Box		1	MR1DS9401			
2	Connection Box Lid		1	MR1DS9411			
3	Packing		1	MR1DS9421			
4	Spacer		4	MS517010			
5	Machine Screw		4	9798556			
6	Machine Screw		4	MS554010			
7	Cable Holder A Assembly		1	60704			
8	Plate Assembly		1	MR1DS5445			
9	Machine Screw w/Spring Washer		4	MS554010			
10	Machine Screw w/Spring Washer		2	MS555010			
11	Electromagnetic Contactor - Hi Speed	SD	1	MGC11226A			
12	Machine Screw w/Spring Washer		2	MS556010			
13	Terminal Plate 16P		1	ECP1416AA			
14	Electromagnetic Contactor		1	MGC22306A			
15	Machine Screw w/Spring Washer		2	MS556010			
16	Machine Screw w/Spring Washer		2	MS556010			
17	Cord Cover Support Packing		1	MS527010			
18	Lid 42		1	E6F630010S			
19	Machine Screw w/Spring Washer		4	MS554010			
20	Warning Seal TM		1	T6PD0059865			
21	Warning Label EE		1	E2D866125			
22	Nameplate B	S	1	B1SHM10S9A6	B1SHM20S9A6	B1SHM30S9A6	B1SHM50S9A6
		L	1	B1SHM10L9A6	B1SHM20L9A6	B1SHM30L9A6	B1SHM50L9A6
		SD	1	B1SHM10B9A6	B1SHM20B9A6	B1SHM30B9A6	B1SHM50B9A6
23	Nameplate C		0				
24	Cable 4C Assembly		1	MR1DS1751	MR1ES1751		
25	P/S Cord 4C		1	14/4	12/4		
26	Plug 4P		1	ES522003	E7S522003		
27	Cable Holder A Assembly		1	60704			
28	Cable Packing		1	ECP6912AA	ECP6916AA		
29	Cable 5C Assembly		1	MR1DS1761	MR1ES1761		
30	P/B Cord 5C		1	14/5			
31	Plug 5P		1	ES613003			
27	Cable Holder A Assembly		1	60704			
32	Cable Packing		1	ECP6914AA			

### Name Plates for 1/8, 1/4, 1/2, 1 1/2 & 2 1/2 Ton Capacities

Figure No.	Part Name	Parts Per Trolley		1/8	1/4	1/2	1 1/2	2 1/2
22	Nameplate B (Blank)	L	1	B1SHM10L9A8				
		S	1	B1SHM10S9A8				
		SD	1	B1SHM10B9A8				
23	Nameplate C		1	B1SHM01S9A7	B1SHM03S9A7	B1SHM05S9A7	B1SHM15S9A7	B1SHM25S9A7

## 9.2 Pendant Parts – 1/8 to 5 Ton

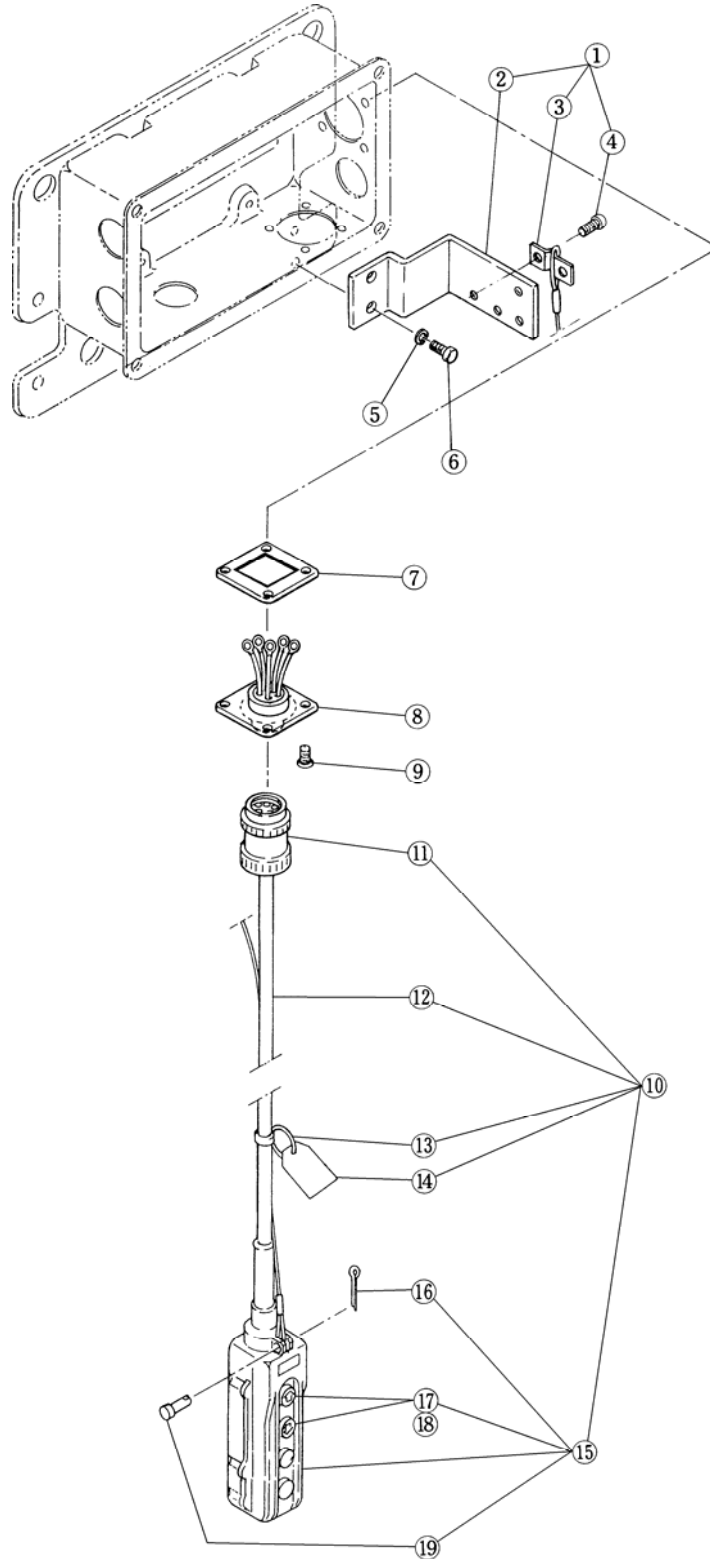


Figure 9-2 Pendant Parts

## 9.2 Pendant Parts – 1/8 to 5 Ton

Figure No.	Part Name	Parts Per Trolley	1 Ton	2 Ton	3 Ton	5 Ton
1	Bar Holder Assembly	1		MR1DS1481		
2	Bar Holder	1		MR1DS9481		
3	Cord Chain Stopper	1		E6L614010S		
4	Machine Screw w/Spring Washer	2		E6F151003		
5	Spring Washer	2		9012712		
6	Socket Bolt	2		9091295		
7	Cord Holder Support Packing	1		MS527010		
8	Socket 8P Assembly	1		MR1DS1811		
9	Machine Screw w/Washer	4		MS554010		
10	Push Button Pendant Assembly 6C	W	1	MR1DSS2781	MR1ESS2781	
		X	1	MR1DSD2781	MR1ESD2781	
		Y	1	MR1DDS2781	MR1EDS2781	
	Push Button Pendant Assembly 8C	Z	1	MR1DDD2781	MR1EDD2781	
11	Plug 8P for 6C Cord	WXY	1	ESM538010 (13.5mm Packing)		
	Plug 8P for 8C Cord	Z	1	ESM538010 (15.0mm Packing)		
12	Push Button Cord 6C		1	16/6P		
	Push Button Cord 8C	Z	1	16/8P		
13	Tag Holder		1	E3S787003		
14	Warning Tag LD		1	WTAG7		
15	4 Push Button Switch Assembly	W	1	ECP311EAB		
		X	1	ECP311FAB		
		Y	1	ECP311GAB		
		Z	1	ECP311HAB		
16	Split Pin		1	9009402		
17	Cap		1	CAP		
18	Arrow Set of 2	SS	1	ARROWS		
		SD	1	ARROWD		
19	Cord Chain Pin B		1	ES628003		

W = SS/SS = Single Speed Hoist, Single Speed Trolley

X = SS/DS = Single Speed Hoist, Dual Speed Trolley

Y = DS/SS = Dual Speed Hoist, Single Speed Trolley

Z = DS/DS = Dual Speed Hoist, Dual Speed Trolley

### 9.3 Power Supply Parts – 1/8 to 5 Ton

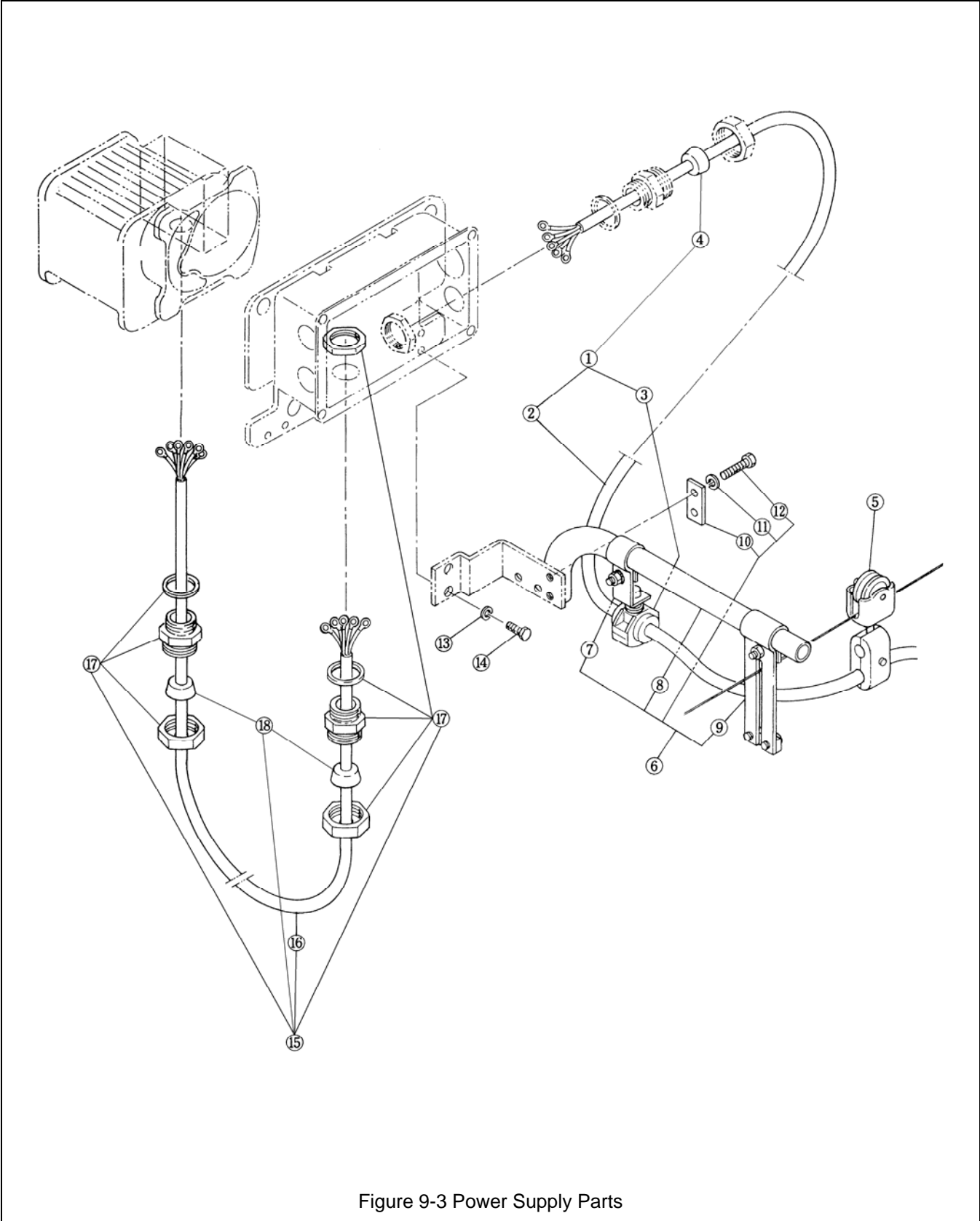


Figure 9-3 Power Supply Parts

### 9.3 Power Supply Parts – 1/8 to 5 Ton

Figure No.	Part Name	Parts Per Trolley		1 Ton	2 Ton	3 Ton	5 Ton
1	Power Supply Cable 4C Assembly		1	MR1DS1771	MR1ES1771		
2	Power Supply Cable 4C		1	14/4	12/4		
3	Cable Support 14 Assembly		1	MS1724010			
4	Cable Packing		1	ECP6916AA	ECP6918AA		
5	Cable Hanger 14 Assembly		6	ES1527003			
6	Cable Support Bar Complete Assembly		1	MR1DS1491			
7	Cable Support Arm		1	MR1DS9492			
8	Cable Support Bar		1	MR1DS9491			
9	Wire Guide Assembly		1	MR1DS1493			
10	Support Bar Holder		1	MR1DS9501			
11	Spring Washer		2	9012711			
12	Hex Head Cap Screw		2	9093329			
13	Spring Washer		2	9012712			
14	Socket Bolt		2	9091295			
15	Trolley Cable Assembly 6C	SS	1	MR1DS1792			
	Trolley Cable Assembly 8C	SD	1	MR1DB1792			
16	Trolley Cable 6C	SS	1	14/6			
	Trolley Cable 8C	SD	1	14/8			
17	Cable Holder A Assembly		2	60704			
18	Cable Packing	SS	2	ECP6914AA			
		SD	2	ECP6916AA			

## 9.4 Side Plates and Suspension Parts – 1/8 to 5 Ton

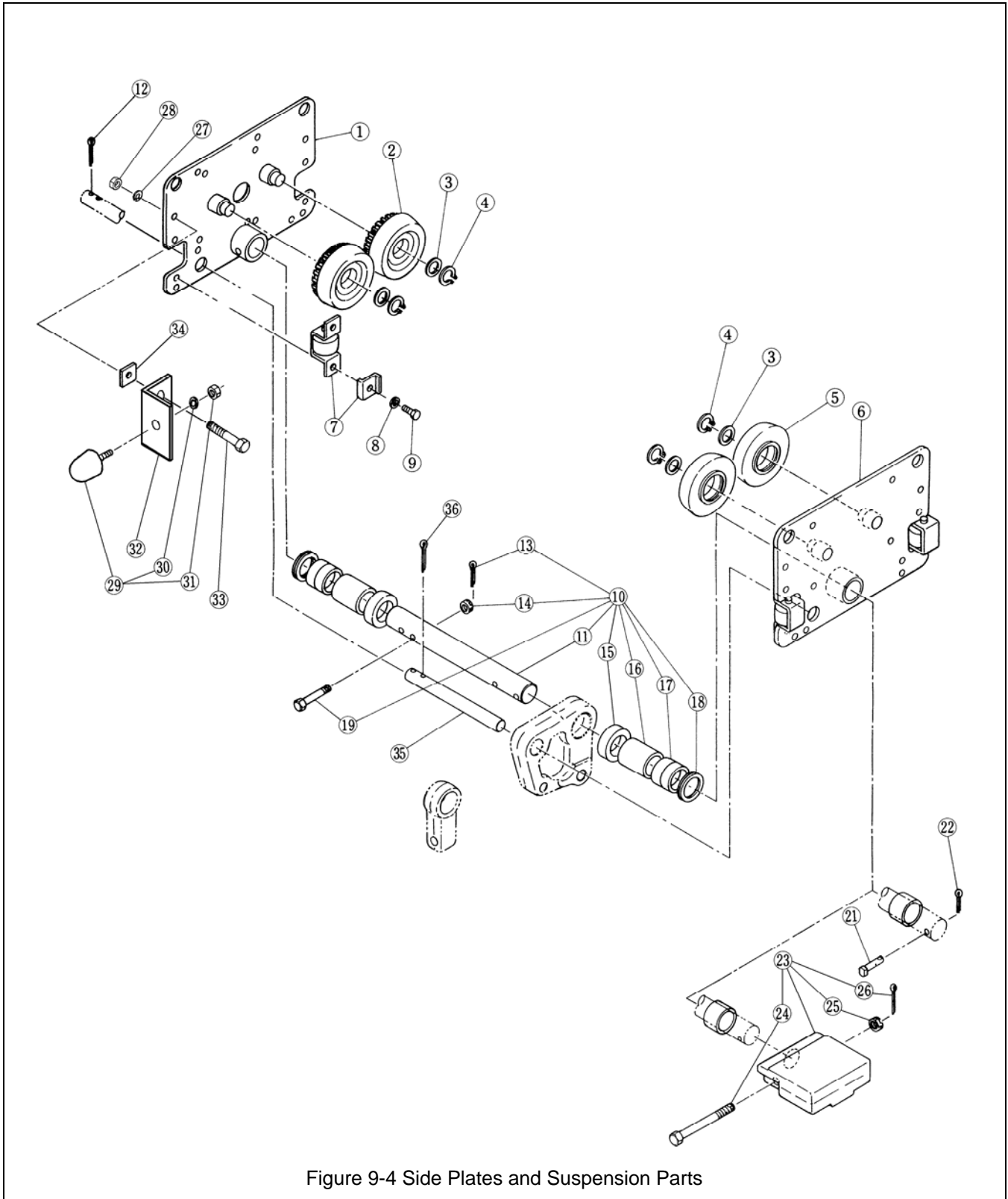


Figure 9-4 Side Plates and Suspension Parts

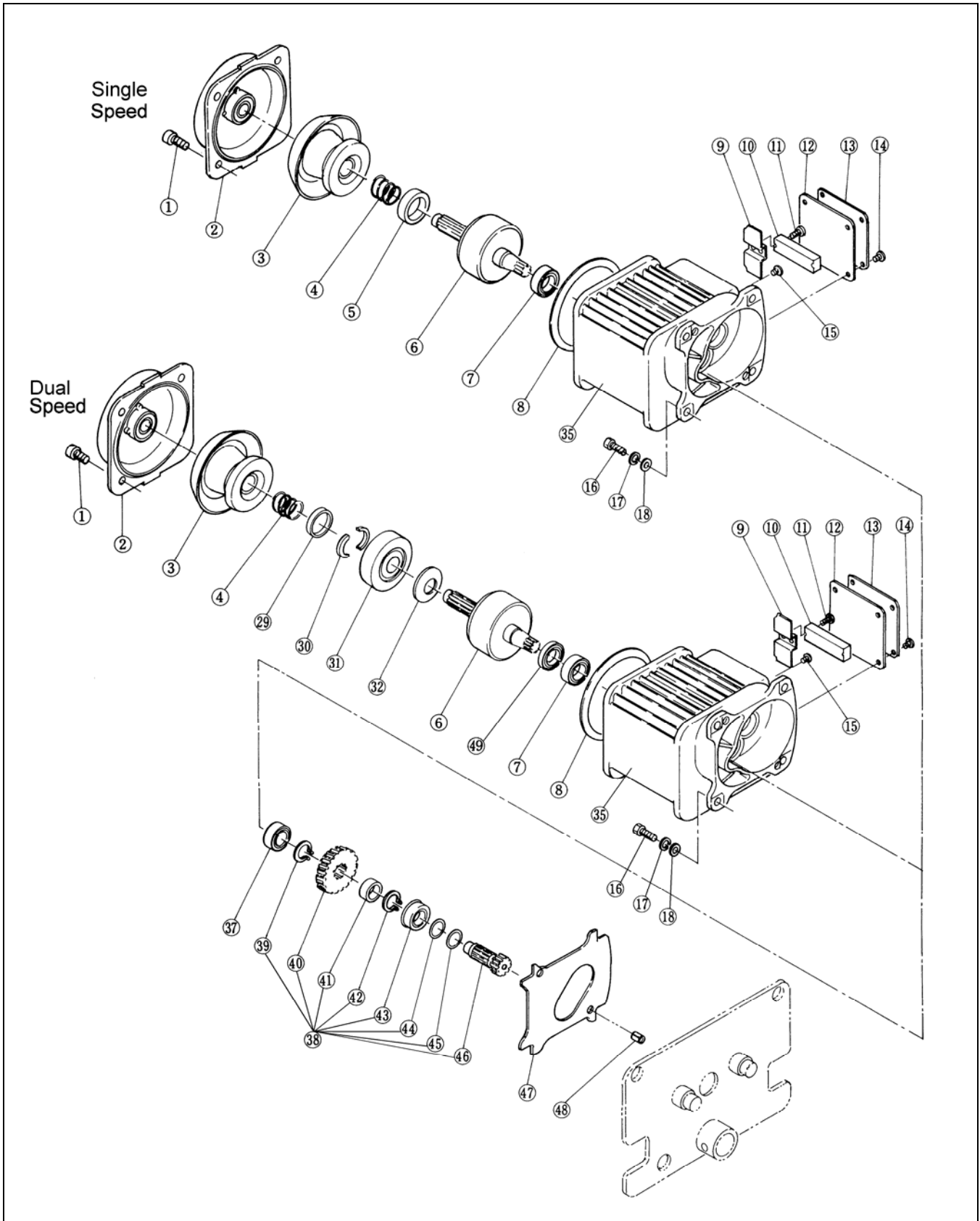
### 9.4 Side Plates and Suspension Parts – All Speeds – 1/8 to 5 Ton

Figure No.	Part Name	Parts Per Trolley		1 Ton	2 Ton	3 Ton	5 Ton
1	Side Plate G Assembly		1	MR1DS5201	MR1ES5201	MR1FS5201	MR1GS5201
2	Track Wheel G Assembly		2	MS1101010	MS1101020	MS1101030	MS1101050
3	Washer		4	MS104010	MS104020	MS104030	MS104050
4	Snap Ring		4	9047115	9047120	9047125	9047135
5	Track Wheel S Assembly		2	MS1102010	MS1102020	MS1102030	MS1102050
6	Side Plate S Assembly		1	MR1DS5202	MR1ES5202	MR1FS5202	MR1GS5202
7	Side Roller Complete Set		4	MR1DS1211	MR1ES1211		MR1GS1211
8	Spring Lock Washer		8	9012711	9012712		9012715
9	Bolt		4	9093329	9093351		9093316
10	Suspension Shaft Complete Set		1	MR1DS1111	MR1ES1111	MR1FS1111	MR1GS1111
11	Suspension Shaft		1	MSF115010	MSF115020	MR1FS9101	MR1GS9101
13	Split Pin		1	9009414-5		90094165	
14	Slotted Nut		1	T3P154020		MS162030	
15	Thick Spacer L		2	MR1DS9110	MR1ES9110	MR1FS9110	MR1GS9110
16	Fixing Spacer		0				
17	Thick Spacer		3	MSF116010	T7G116030	MSF116030	MSF116050
18	Thin Spacer		8	MSF117010	MSF117020	MSF117030	MSF117050
19	Bolt		1	MS161010	MS161020	MS161030	MS161050
21	Shaft Stopper		1	T6G156020	MS164020	MS164030	MS164050
22	Split Pin		1	9009432		9009433	
23	Balance Weight Complete Set	SD	1	MR1DB1621			
24	Weight Bolt	SD	1	MR1DB9622			
25	Slotted Nut	SD	1	MS162010			
26	Split Pin	SD	1	9009413			
27	Spring Washer		8	9012711	9012712		9012715
28	Nut		8	9093424	9093427		9093433
29	Bumper		4	MR1DS9631		MR1FS9631	
30	Spring Washer		4	9012711			
31	Nut		4	9093424			
32	Angle		4	MR1DS9634	MR1ES9634		MR1GS9634
33	Bolt		8	9093330	9093352		9093318
34	Square Spacer		4	MS006010	MS006020		MS006050
35	Fixing Shaft		1	MR1DS9131	MR1ES9131	MR1FS9131	MR1GS9131
36	Split Pin		2	9009446		9009448	

#### EXTENDED SUSPENSION SHAFT PARTS

Figure No.	Part Name	Parts Per Trolley		1 Ton	2 Ton	3 Ton	5 Ton
10	Suspension Shaft Complete Set		1	MR1DS1112	MR1ES1112	MR1FS1112	MR1GS1112
11	Suspension Shaft		1	MSF181010	MSF181020	MR1FS9121	MR1GS9121
13	Split Pin		1	90094145		90094165	
14	Slotted Nut		1	T3P154020		MS162030	
15	Thick Spacer L		2	MR1DS9110	MR1ES9110	MR1FS9110	MR1GS9110
16	Fixing Spacer		2	MSF182010	MSF182020	MSF182030	
17	Thick Spacer	(X)		MSF116010 (9)	T7G116030 (9)	MSF116030 (9)	MSF116050 (13)
18	Thin Spacer		8	MSF117010	MSF117020	MSF117030	T6G120050
19	Bolt		1	MS161010	MS161020	MS161030	MS161050
21	Shaft Stopper		1	T6G156020	MS164020	MS164030	MS164050
22	Split Pin		1	9009432		9009433	
35	Fixing Shaft		1	MR1DS9141	MR1ES9141	MR1FS9141	MR1GS9141
36	Split Pin		2	9009446		9009448	

# 9.5 Motor Parts – 1/8 to 5 Ton



## 9.5 Motor Parts – 1/8 to 5 Ton

Figure No.	Part Name	Parts Per Hoist		1 Ton	2 Ton	3 Ton	5 Ton
1	Socket Bolt		4	90912134			
2	Motor Cover Assembly		1	MR1DS1301			
3	Brake Drum Assembly	SS	1	MR1DS5261			
		SD	1	MR1DB5261			
4	Brake Spring	SS	1	MS304010			
		SD	1	MR1DB9264			
5	Bumper	SS	1	MR1DS9265			
6	Motor Shaft with Rotor	SS	1	MR1DS5291			MR1GS5291
		SD	1	MR1DB5291		MR1FB5291	
7	Ball Bearing		1	9001004			
8	Guard		1	MR1DS9281			
9	Coil Cover		1	MR1DS9326			
10	Terminal Plate 6P	SS	1	MS518010			
	Terminal Plate 6P	SD	2	E6F606003			
11	Machine Screw w/Spring Washer	SS	2	MS556010			
		SD	4				
12	Terminal Cover Packing	SS	1	MR1DS9325			MR1GS9325
		SD	1	MR1GS9325			
13	Terminal Cover	SS	1	MR1DS9324			MR1GS9324
		SD	1	M7SE010B9206			
14	Machine Screw w/Spring Washer		4	MS554010			
15	Machine Screw w/Spring Washer		1	MS555010			
16	Bolt		4	9093328			
17	Spring Washer		4	9012711			
18	Washer		4	9012513			
29	Thrust Collar	SD	1	ES506005S			
30	Thrust Disc	SD	2	ES505005S			
31	Pull Rotor	SD	1	ES503005S			
32	Coned Disc Spring	SD	1	ES504005S			
35	Motor Frame w/Stator 208-230/460V	SS	1	B1SHM10S5A2			B1SHM50S5A2
		SD	1	B1SHM10B5A2		B1SHM30B5A2	
	Motor Frame w/Stator 575V	SS	1	B1SHA10S5A2			B1SHA50S5A2
		SD	1	B1SHA10B5A2		B1SHA30B5A2	
37	Ball Bearing		1	E2D238125			
38	Gear Set 80 FPM	S	1	MR1DS1241	MR1ES1241	MR1GS1241	
	Gear Set 40 FPM	L	1	MR1DL1241	MR1EL1241	MR1GL1241	
	Gear Set 80/20 FPM	SD	1	MR1DL1241	MR1EL1241	MR1GL1241	
39	Snap Ring		1	9047120			
40	Gear #2 40 FPM	L	1	MR1DL9241			
	Gear #2 80 FPM	S	1	MR1DS9241			
41	Spacer		1	MR1DS9244			
42	Snap Ring		1	9047120			
43	Ball Bearing		1	9001211			
44	O Ring		1	MR1DS9254			
45	O Ring		1	9013316			
46	Gear #3		1	MR1DS9242	MR1ES9242	MR1GS9242	
47	Gear Box Packing		1	MR1DS9248			
48	Set Pin		2	MR1DS9249			
49	Oil Seal		1	MR1DS9293			

## 9.6 Motor Parts – 8 to 20 Ton

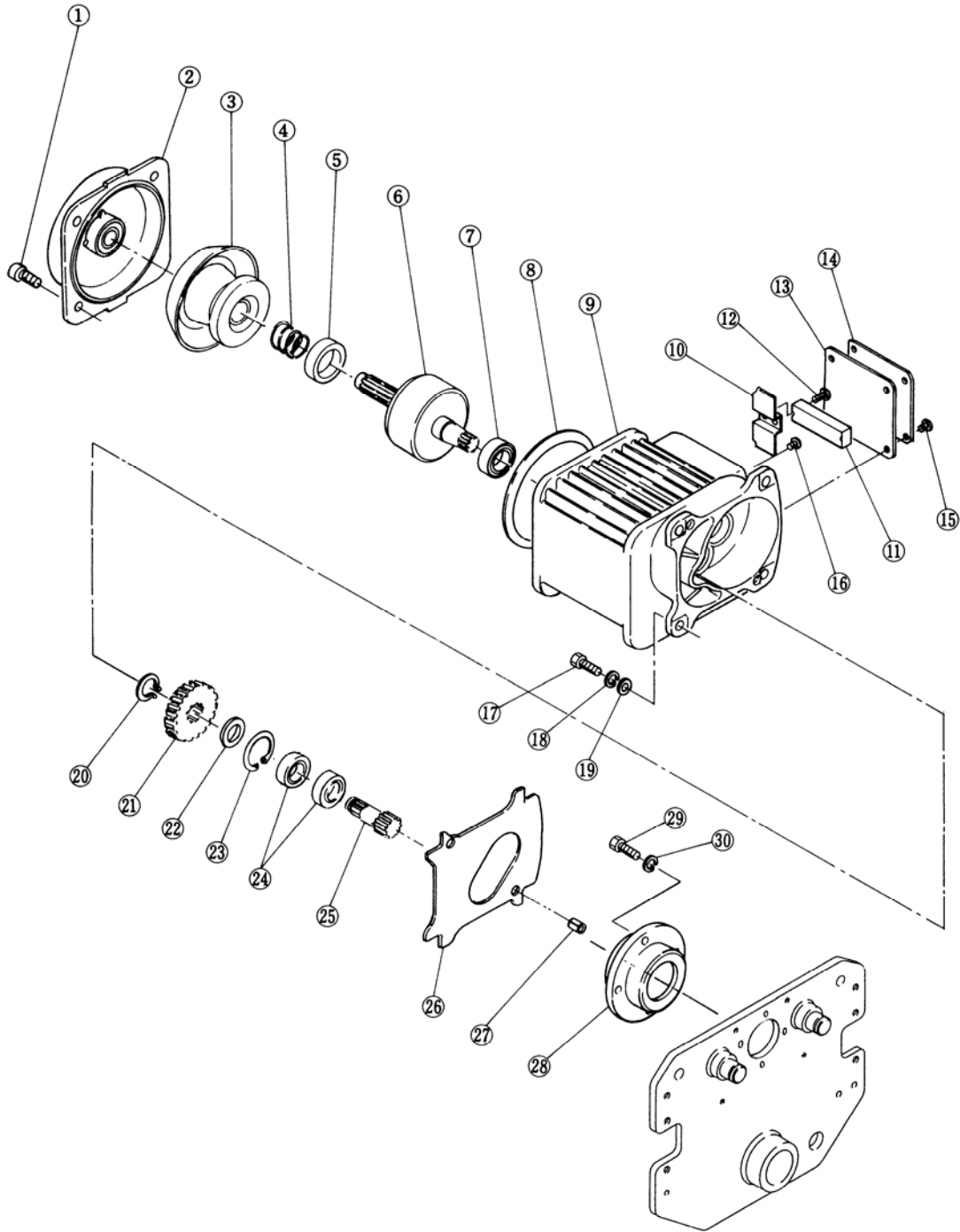
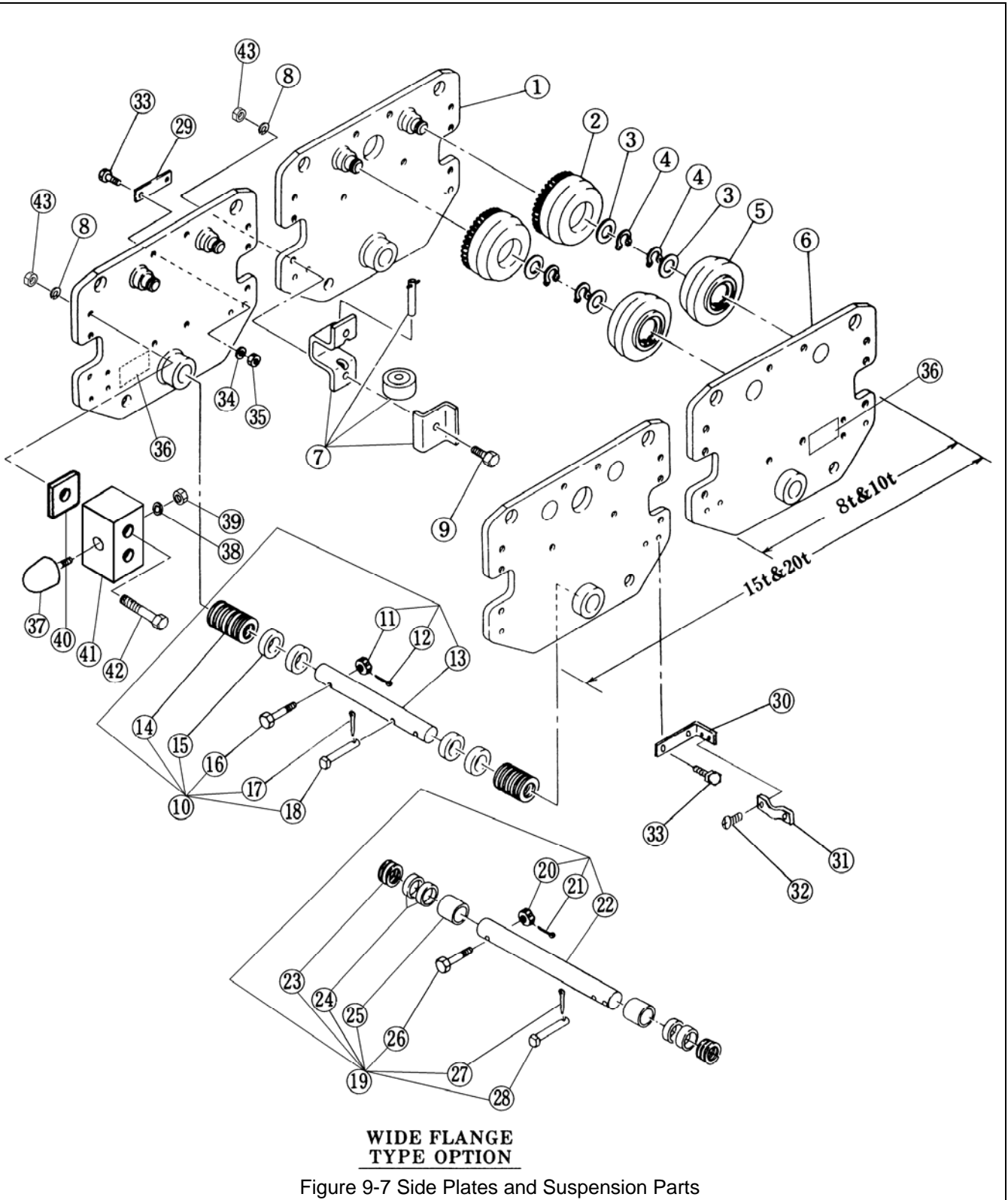


Figure 9-6 Motor Parts

## 9.6 Motor Parts – 8 to 20 Ton

Figure No.	Part Name	Single Body Trolley			Double Body Trolley			
		Parts Per Trolley	080	100L	100S	Parts Per Trolley	150	200
1	Socket Bolt	4		90912134		8		90912134
2	Motor Cover Assembly	1		MR1DS1301		2		MR1DS1301
3	Brake Drum Assembly	1		MR1DS5261		2		MR1DS5261
4	Brake Spring	1		MS304010		2		MS304010
5	Bumper	1		MR1DS9265		2		MR1DS9265
6	Motor Shaft with Rotor	1		MR1GS5291		2		MR1GS5291
7	Ball Bearing	1		9001004		2		9001004
8	Guard	1		MR1DS9281		2		MR1DS9281
9	Motor Frame with Stator	1		B1SHM50S5A2		2		B1SHM50S5A2
10	Coil Cover	1		MR1DS9326		2		MR1DS9326
11	Terminal Plate 6P	1		MS518010		2		MS518010
12	Machine Screw with Spring Washer	2		MS556010		4		MS556010
13	Terminal Cover Packing	1		MR1GS9325		2		MR1GS9325
14	Terminal Cover	1		M6F206D010		2		M6F206D010
15	Machine Screw with Spring Washer	4		MS554010		8		MS554010
16	Machine Screw with Spring Washer	1		MS555010		2		MS555010
17	Bolt	4		9093328		8		9093328
18	Spring Washer	4		9012711		8		9012711
19	Washer	4		9012513		8		9012513
20	Snap Ring	1		9047125		2		9047125
21	Gear #2 (S)	1		MR1IS9241		2		MR1IS9241
22	Spacer	1		MR1IS9244		2		MR1IS9244
23	Snap Ring	1		9047252		2		9047252
24	Ball Bearing	2		9000605		4		9000605
25	Gear #3	1		MR1IS9242		2		MR1IS9242
26	Gear Box Packing	1		MR1IS9248		2		MR1IS9248
27	Set Pin	2		MR1DS9249		4		MR1DS9249
28	Bearing Holder	1		MR1IS9257		2		MR1IS9257
29	Socket Bolt	4		90912138		8		90912138
30	Spring Lock Washer	4		9012709		8		9012709

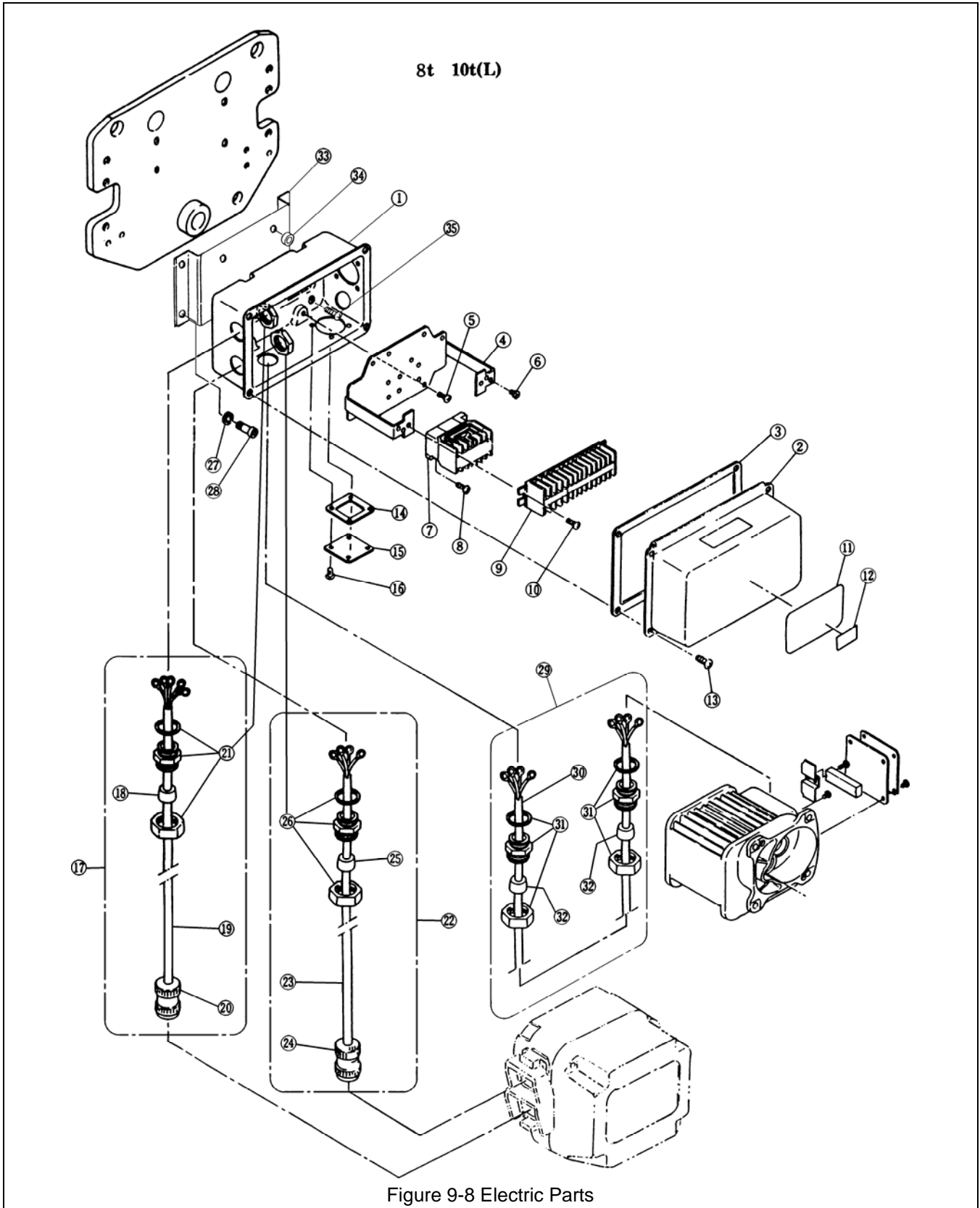
## 9.7 Side Plates and Suspension Parts – 8 to 20 Ton



## 9.7 Side Plates and Suspension Parts – 8 to 20 Ton

Figure No.	Description	Parts per Trolley	Single Body Trolley			Double Body Trolley		
			080	100L	100S	Parts per Trolley	150	200
1	Side Plate G Assembly	1		MR1IS5201		2		MR1IS5201
2	Track Wheel G Assembly	2		MS1101075		4		MS1101075
3	Washer	2		MS104075		4		MS104075
4	Snap Ring	4		9047145		8		9047145
5	Track Wheel P Assembly	2		MS1102075		4		MS1102075
6	Side Plate S Assembly	1		MR1IS5202		2		MR1IS5202
7	Side Roller Set	4		MR1GS1211		8		MR1GS1211
8	Spring Lock Washer	12		9012715		24		9012715
9	Bolt	4		90933116		8		90933116
10	Suspension Shaft Assembly (200)	1		M6SS100S1115		2		M6SS100S1115
11	Slotted Nut	1		ES088020L		1		ES088020L
12	Split Pin	1		9009436		1		9009436
13	Suspension Shaft (220)	1		MS115075		1		MS115075
14	Adjusting Spacer	8		MS116075		16		MS116075
15	Fixing Spacer	6		MS117075		12		MS117075
16	Bolt	1		MS161100		2		MS161100
17	Split Pin	1		MS165075		2		MS165075
18	Shaft Stopper Pin	1		MS164075		2		MS164075
19	Suspension Shaft Assembly (300)	1		MSF181075		2		MSF181075
20	Slotted Nut	1		ES088020L		2		ES088020L
21	Split Pin	1		9009436		2		9009436
22	Suspension Shaft (300)	1		M6SE100S9181		2		M6SE100S9181
23	Adjusting Spacer	8		MS116075		16		MS116075
24	Fixing Spacer	7		MS117075		14		MS117075
25	Thick Fixing Spacer	2		M6SE100S9182		4		M6SE100S9182
26	Bolt	1		MS161100		2		MS161100
27	Split Pin	1		MS165075		2		MS165075
28	Shaft Stopper Pin	1		MS164075		2		MS164075
29	Connection Plate	0				4		MS105150
30	Connection Plate S	0				1		MR1JS9225
31	Cord Chain Stopper	0				1		E6L614010S
32	Machine Screw with Spring Washer	0				2		MS554010
33	Bolt	0				4		MS106150
34	Spring Washer	0				4		9012713
35	Nut	0				4		9093433
36	Warning Seal TM	1		T6PD0059865		2		T6PD0059865
37	Bumper	4		MR1FS9631		8		MR1FS9631
38	Spring Washer	4		9012711		8		9012711
39	Nut	4		9093424		8		9093424
40	Square Spacer	4		MS006050		8		MS006050
41	Bumper Block	4		MR1IS9634		8		MR1IS9634
42	Bolt	8		9093196		16		9093196
43	Nut	12		9093439		24		9093439

# 9.8 Electric Parts – 8 to 20 Ton



## 9.8 Electric Parts – 8 to 20 Ton

Figure No.	Description	Parts Per Trolley	080	100L
1	Connection Box	1	MR1DS9401	
2	Connection Box Lid	1	MR1DS9411	
3	Packing	1	MR1DS9421	
4	Plate Assembly	1	MR1IS5445	
5	Machine Screw with Spring Washer	4	MS554010	
6	Machine Screw with Spring Washer	4	MS555010	
7	Electromagnetic Contactor	1	MGC22306A	
8	Machine Screw with Spring Washer	2	MS556010	
9	Terminal Plate18 p	1	ECP1518AA	
10	Machine Screw with Spring Washer	2	MS556010	
11	Name Plate B	1	80059	B1SHM10L9A8
12	Name Plate C	1		B1SHM1QS9A7
13	Machine Screw with Spring Washer	4	MS554010	
14	Cord Holder Packing	1	ECP5924AC	
15	Lid 42	1	MF630010	
16	Machine Screw with Spring Washer	4	MS554010	
17	Cable 5C Complete Set	1	MR1HS1761	
18	Cable Packing	1	ECP6912AA	
19	S.O. Cord	1	14/6	
20	Plug 5P	1	ES613003	
21	Cable Holder Assembly	1	60704	
22	Cable 4C Complete Set	1	MR1HS1751	
23	S.O. Cord	1	12/4	
24	Plug 4P	1	ECP2304AA	
25	Cable Packing	1	ECP6914AA	
26	Cable Holder Assembly	1	60704	
27	Spring Washer	4	9012711	
28	Socket Bolt	4	9091272	
29	Trolley Cable 4C Assembly	1	MR1HS1791	
30	S.O. Cord	1	12/4	
31	Cable Holder A Assembly	1	60704	
32	Cable Packing	1	ECP6914AA	
33	Plate	1	MR1HS9405	
34	Spacer	4	MS517010	
35	Machine Screw with Spring Washer	4	MS551010	

# 9.9 Electric Parts Single Speed – 8 to 20 Ton

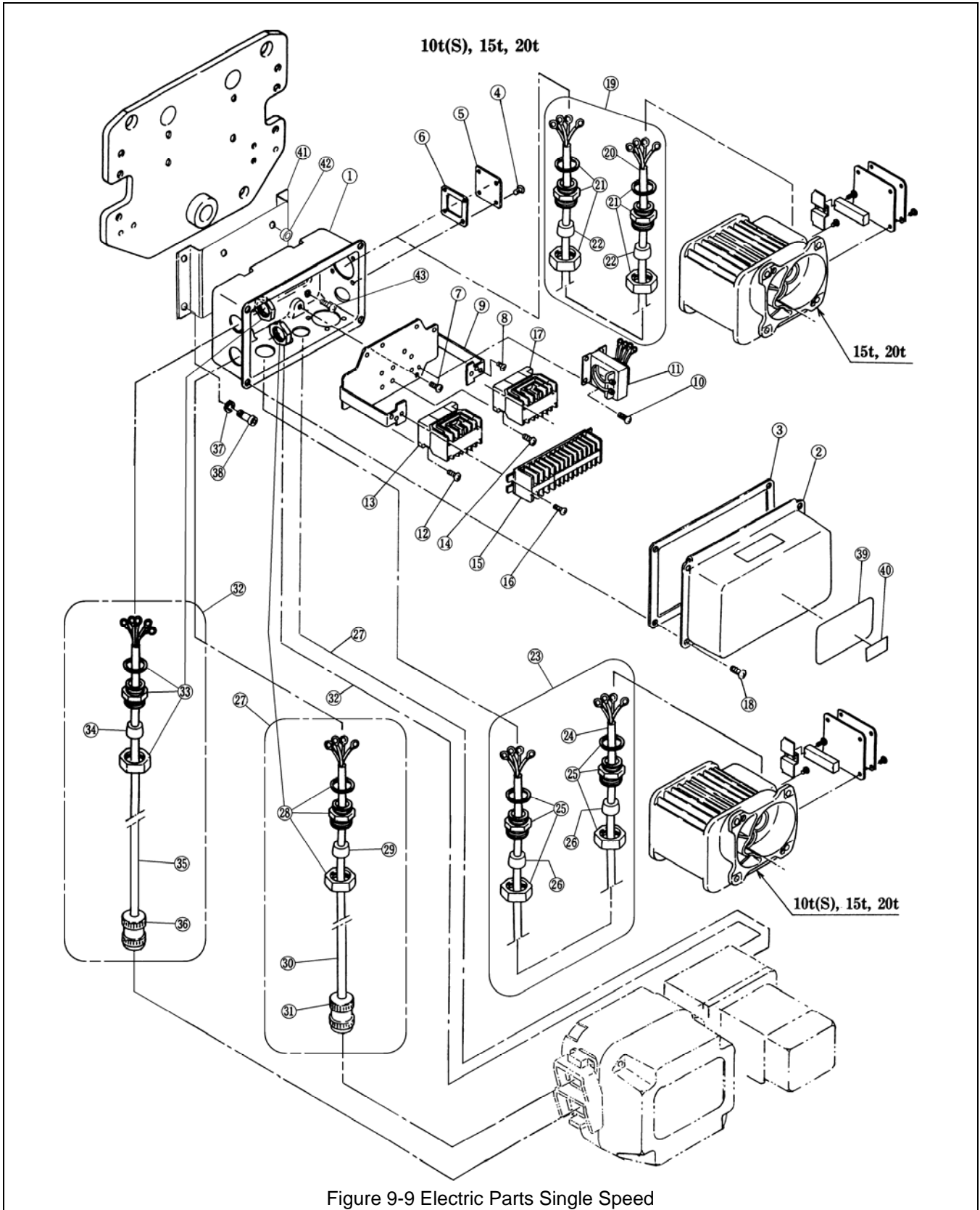


Figure 9-9 Electric Parts Single Speed

## 9.9 Electric Parts Single Speed – 8 to 20 Ton

Figure No.	Description	Parts Per Trolley	100S	150	200
1	Connection Box	1		MR1DS9401	
2	Connection Box Lid	1		MR1DS9411	
3	Switch Box Packing	1		MR1DS9421	
4	Machine Screw with Spring Washer	4		MS554010	
5	Lid 42	1		MF630010	
6	Cord Holder Support Packing	1		MS527010	
7	Machine Screw with Spring Washer	4		MS554010	
8	Machine Screw with Spring Washer	6		MS555010	
9	Plate Assembly	1		MR1IS445	
10	Machine Screw with Spring Washer	3		MS555010	
11	Transformer	1		TRF62M601	
12	Machine Screw with Spring Washer	2		MS556010	
13	Electromagnetic Contactor	1		MGC23306A	
14	Machine Screw with Spring Washer	2		MS556010	
15	Terminal Plate 18 p	1		ECP1518AA	
16	Machine Screw with Spring Washer	2		J1AW2-4001010	
17	Electromagnetic Contactor	1		MGC22306A	
18	Machine Screw with Spring Washer	4		MS554010	
19	Trolley Cable 4C Assembly	1		MR1HS1792	
20	S.O. Cord	1		12/4	
21	Cable Holder Assembly	4		60704	
22	Cable Packing	4		ECP6914AA	
23	Trolley Cable 4C Assembly	1	MR1HS1792		
24	S.O. Cord	1	12/4		
25	Cable Holder Assembly	2	60704		
26	Cable Packing	2	ECP6914AA		
27	Cable 4C Complete Set	2	MR1IS1751	MR1JS1751	
28	Cable Holder A Assembly	2		60704	
29	Cable Packing	2		ECP6914AA	
30	Cable 4C	2		12/4	
31	Plug 4P	1		ECP2304AA	
32	Cable 3C Complete Set	2	MR1IS1761	MR1JS1761	
33	Cable Holder Assembly	2		60704	
34	Cable Packing	2		ECP6912AA	
35	S.O. Cord	2		14/4	
36	Plug 5P	2		ES613003	
37	Spring Washer	4		9012711	
38	Socket Bolt	4		9091272	
39	Name Plate B (Blank)	1		MR1SHM10L9A8	
40	Name Plate C	1	B1SHM1QS9A7	B1SHM1PS9A7	B1SHM2QS9A7
41	Plate	1		MR1HS9405	
42	Spacer	4		MS517010	
43	Machine Screw with Spring Washer	4		MS551010	

## 9.10 Electric Parts Dual Speed – 8 to 20 Ton

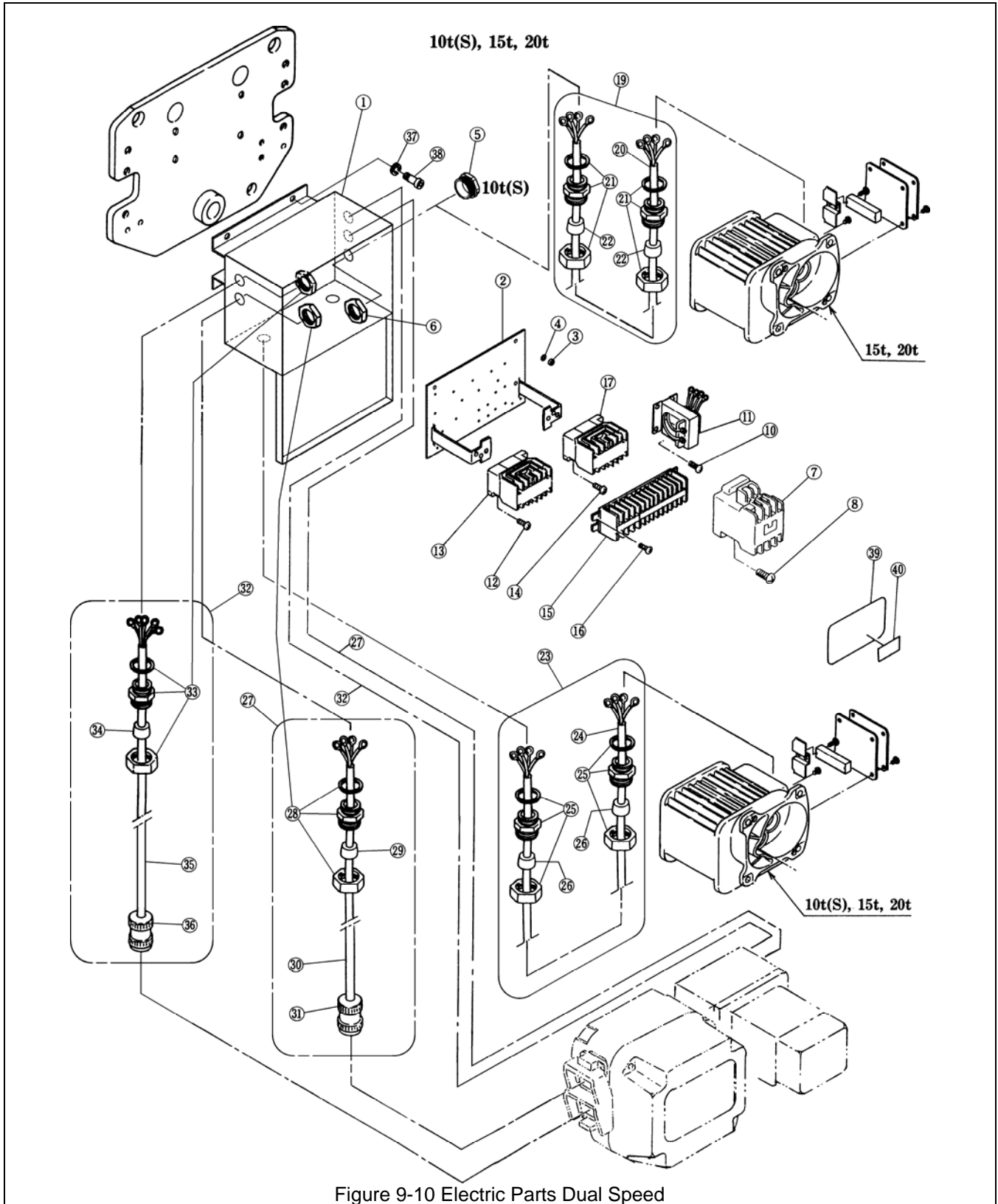


Figure 9-10 Electric Parts Dual Speed

## 9.10 Electric Parts Dual Speed – 8 to 20 Ton

Figure No.	Description	Parts Per Trolley	100S	150	200
1	Connection Box Assembly	1	MR1IS1470		
2	Panel Plate Assembly	1	MR1DHM1QS1A5		
3	Nut	4	9093425		
4	Spring Washer	4	9012711		
5	Holder Cover	1	ECP5924AE		
6	Holder Nut	1	ECP5924AD		
7	Electromagnetic Contactor	1	MGC11226A		
8	Machine Screw with Spring Washer	6	MS556010		
10	Machine Screw with Spring Washer	3	MS555010		
11	Transformer	1	TRF62M501		
12	Machine Screw with Spring Washer	2	MS556010		
13	Electromagnetic Contactor	1	MGC23306A		
14	Machine Screw with Spring Washer	2	MS556010		
15	Terminal Plate 18 p	1	ECP1518AA		
16	Machine Screw with Spring Washer	2	J1AW2-4001010		
17	Electromagnetic Contactor	1	MGC22306A		
18	Machine Screw with Spring Washer	4	MS554010		
19	Trolley Cable 4C Assembly	1		MR1HS1792	
20	S.O. Cord	1		12/4	
21	Cable Holder Assembly	4		60704	
22	Cable Packing	4		ECP6914AA	
23	Trolley Cable 4C Assembly	1	MR1HS1792		
24	S.O. Cord	1	12/4		
25	Cable Holder Assembly	2	60704		
26	Cable Packing	2	ECP6914AA		
27	Cable 4C Complete Set	2	MR1IS3751		
28	Cable Holder A Assembly	2	60704		
29	Cable Packing	2	ECP6914AA		
30	Cable 4C	2	12/4		
31	Plug 4P	1	ECP2304AA		
32	Cable 4C Complete Set	2	MR1IS3761		
33	Cable Holder Assembly	2	60704		
34	Cable Packing	2	ECP6912AA		
35	S.O. Cord	2	14/4		
36	Plug 5P	2	ES613003		
37	Spring Washer	4	9012711		
38	Socket Bolt	4	9091272		
39	Name Plate B (Blank)	1	MR1SHM10L9A8		
40	Name Plate C	1	B1SHM1QS9A7	B1SHM1PS9A7	B1SHM2QS9A7

## 9.11 Power Supply Parts – 8 to 20 Ton

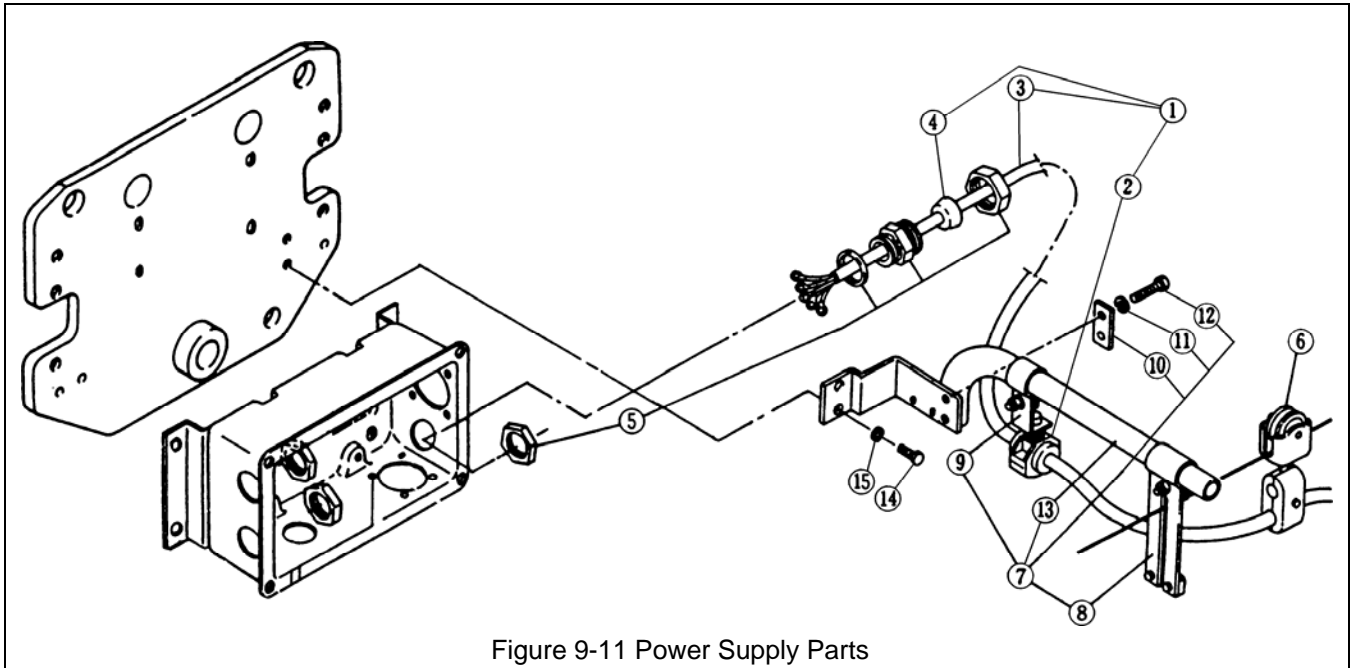


Figure 9-11 Power Supply Parts

Figure No.	Description	Parts per Trolley	080	100L	100S	150	200
1	Power Supply Cable 4C Assembly	1	MR1ES177130			MR1JS177130	
2	Cable Support Assembly	1	M3EN01017242			M7HE010M1105	
3	S.O. Cord	1	12/4			10/4	
4	Cable Packing	1	ECP6918AA			ECP6922AA	
5	Cable Holder A Assembly	1			60704		
6	Cable Hanger14 Assembly	1			ES1527003		
7	Cable Support Bar Complete Set	1			MR1DS1491		
8	Wire Guide Assembly	1			MR1DS1493		
9	Cable Support Arm	1			MR1DS9492		
10	Support Bar Holder	1			MR1DS9501		
11	Spring Washer	2			9012711		
12	Hex Head Cap Screw	2			9093329		
13	Cable Support Bar	1			MR1DS9491		
14	Socket Bolt	2			9091295		
15	Spring Washer	2			9012712		

**This Page Intentionally Left Blank**

## 9.12 Pendant Parts – 8 to 20 Ton

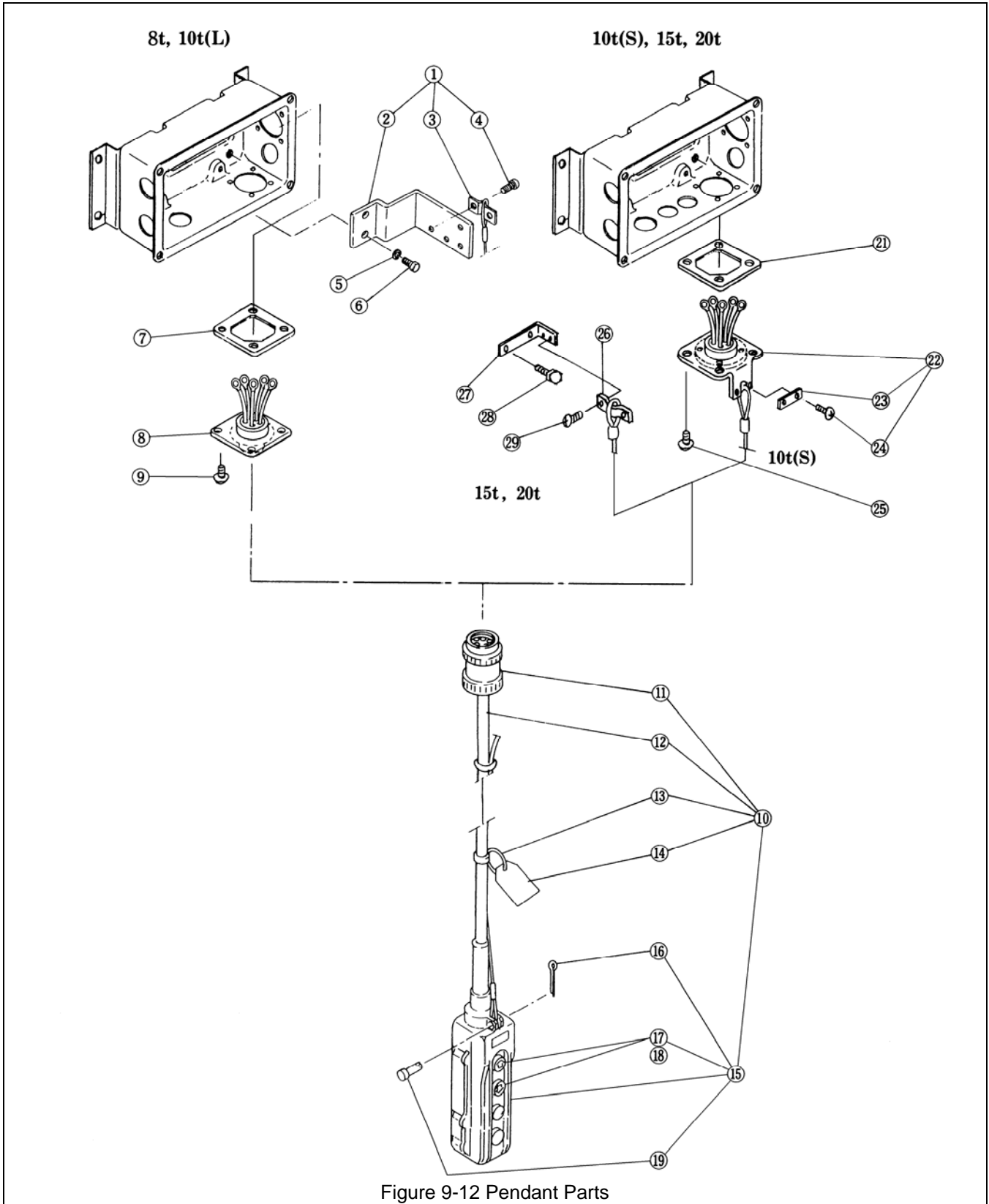


Figure 9-12 Pendant Parts

## 9.12 Pendant Parts – 8 to 20 Ton

Figure No.	Description	Parts Per Trolley		080	100L	100S	150	200
1	Bar Holder Assembly	1		MRDS1481				
2	Bar Holder	1		MR1DS9481				
3	Cord Chain Stopper	1		E6L614010S				
4	Machine Screw with Spring Washer	2		MS554010				
5	Spring Washer	2		9012712				
6	Socket Bolt	2		9091295				
7	Cord Holder Support Packing	1		MS527010				
8	Socket 8P Assembly	1		MR1DS1811				
9	Machine Screw with Spring Washer	4		MS554010				
10	Push Button Assembly	S	1	MR1HSS1781		MR1ISS1781		MR1JSS1781
		D		MR1HDS1781		MR1IDS1781		MR1JDS1781
11	Plug 8P	1				ESM538010		
12	Pendant Cable	S	1			16/6P		
		D	1			16/8P		
13	Tag Holder	1				E3S787003		
14	Warning Tag PB	1				WTAG7		
15	4 Push Button Switch Assembly	S	1			ECP311EAB		
		D	1			ECP311GAB		
16	Split Pin	1				9009402		
17	Cap	1				CAP		
18	Arrow Set of 2	S	1			ARROWS		
		D	1			ARROWD		
19	Cord Chain Pin B	1				ES628003		
21	Cord Holder Support Packing	1				MS527010		
22	Socket 8P Assembly	1				MR1DS1811		
23	Cord Chain Stopper	1				M6F530010		
24	Machine Screw with Spring Washer	1				MS554010		
25	Machine Screw with Spring Washer	1				MS554010		
26	Cord Chain Stopper	1				E6L614010S		
27	Connection Plate S	1				MR1JS9225		
28	Bolt	2				MS106150		
29	Machine Screw with Spring Washer	2				MS554010		

S = Single Speed Hoist

D = Dual Speed Hoist

### 9.13 Optional Parts – 8 to 20 Ton

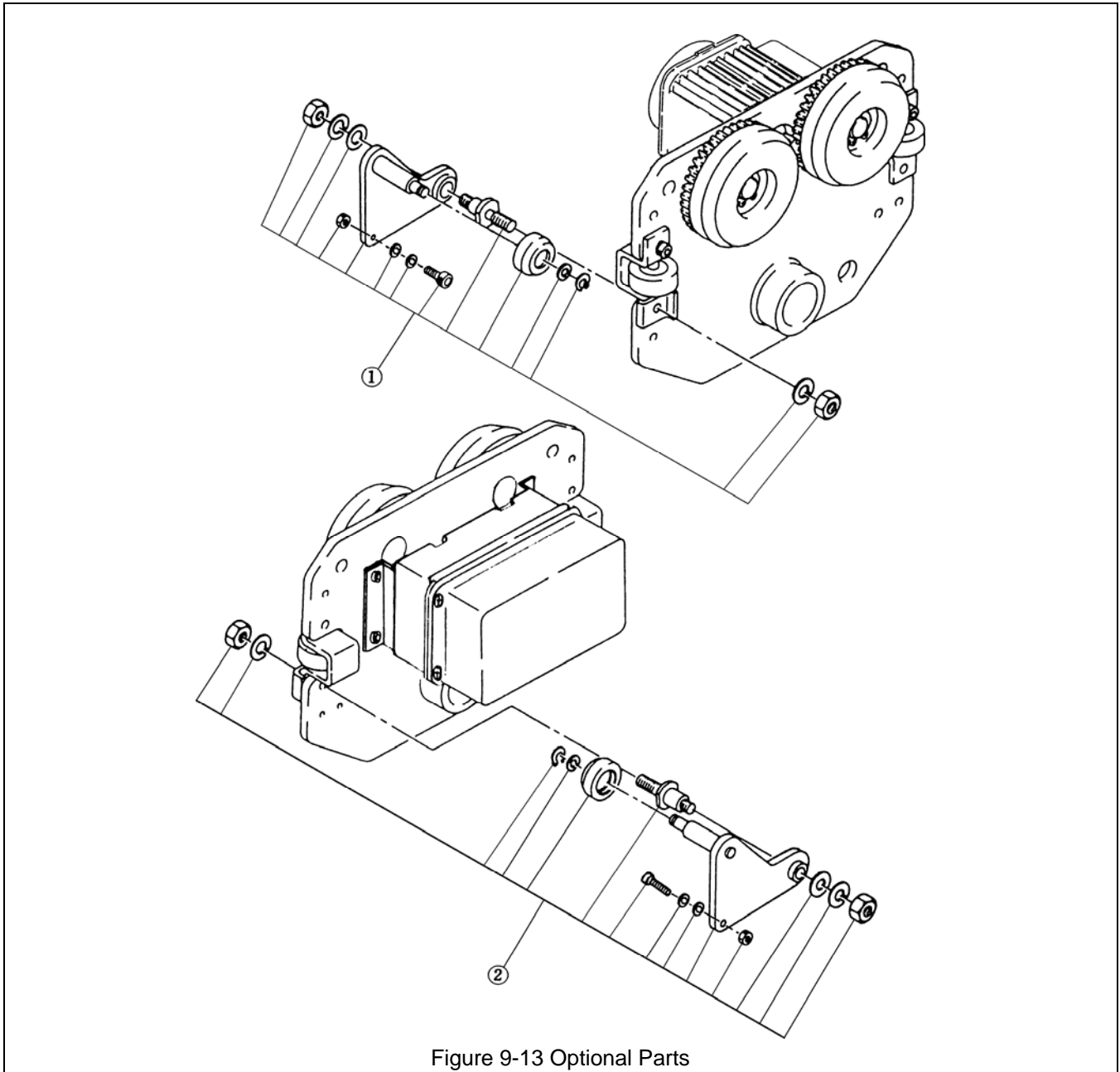


Figure 9-13 Optional Parts

Figure No.	Description	080	100L	100S	200
1	Hanger Plate A Assembly	MS1401075			
2	Hanger Plate B Assembly	MS1402075			

**This Page Intentionally Left Blank**



[www.harringtonhoists.com](http://www.harringtonhoists.com)

Harrington Hoists, Inc.  
401 West End Avenue  
Manheim, PA 17545-1703  
Phone: 717-665-2000  
Toll Free: 800-233-3010  
Fax: 717-665-2861

Harrington Hoists – Western Division  
2341 Pomona Rd. #103  
Corona, CA 92880-6973  
Phone: 951-279-7100  
Toll Free: 800-317-7111  
Fax: 951-279-7500

**MROM**