OWNER'S MANUAL

HPC500 Series Top Running and Underhung End Trucks

½ Ton, 1 Ton, and 2 Ton Capacity

Code and Serial No.

⚠ WARNING

This equipment should not be installed, operated or maintained by any person who has not read and understood all the contents of this manual. Failure to read and comply with the contents of this manual can result in serious bodily injury or death, and/or property damage.

HARRINGTON
HOISTS AND CRANES

Table of Contents

Section	Page Number
1.0 Important Information and Warnings.....	3
1.1 Terms and Summary	
1.2 Warning Tags and Labels	
2.0 Technical Information.....	5
2.1 Specifications	
2.2 Part Names	
3.4 3.0	
Pre-operational Procedures.....	9
3.1 Runway	
3.2 Bridge Beam	
3.3 End Trucks	
3.0 Pre-operational Checks and Trial Operation	
3.1 Runway	
3.2 Bridge Beam	
3.3 End Trucks	
3.4 Pre-operational Checks and Trial Operation	
4.0 Operation.....	18
4.1 Introduction	
4.2 Important Information about Operation	
5.0 Inspection.....	19
5.1 General	
5.2 Inspection Classification	
5.3 Frequent Inspection	
5.4 Periodic Inspection	
5.5 Occasionally Used End Trucks	

5.6	Inspection Records	
5.7	Inspection Methods and Criteria	
6.0	Lubrication.....	24
6.1	HPC500 End Trucks	
6.2	Other Equipment	
7.0	Maintenance & Handling.....	25
7.1	General	
7.2	Storage	
7.3	Outdoor Installations	
8.0	Troubleshooting	26
9.0	Warranty.....	27
10.0	Parts List.....	28

1.0 Important Information and Warnings

1.1 Terms and Summary

This manual provides important information for personnel involved with the installation, operation, and maintenance of this product. Although you may be familiar with this or similar equipment, it is strongly recommended that you read this manual before installing, operating, or maintaining the product.

Danger, Warning, Caution, and Notice

Throughout this manual there are steps and procedures that can present hazardous situations. The following signal words are used to identify the degree or level of hazard seriousness.

⚠ DANGER Danger indicates an imminently hazardous situation which, if not avoided, **will** result in **death or serious injury**, and property damage.

⚠ WARNING Warning indicates an imminently hazardous situation which, if not avoided, **could** result in **death or serious injury**, and property damage.

⚠ CAUTION Caution indicates a potentially hazardous situation which, if not avoided, **may** result in **minor or moderate injury** or property damage.

NOTICE Notice is used to notify people of installation, operation, or maintenance information which is important but not directly hazard-related.

⚠ CAUTION

These general instructions deal with the normal installation, operation, and maintenance situations encountered with the equipment described herein. The instructions should not be interpreted to anticipate every possible contingency or to anticipate the final system, crane, or configuration that uses this equipment. For systems using the equipment covered by this manual the supplier and owner of the system are responsible for the system's compliance with all applicable industry standards, and with all applicable Federal, State, and Local regulations/codes.

This manual includes instructions and parts information for a variety of hoist types. Therefore, all instructions and parts information may not apply to any one type or size of specific hoist. Disregard those portions of the instructions that do not apply.

Record your end trucks' Code and Serial No. (see Figure 10-1) on the front cover of this manual for identification and future reference to avoid referring to the wrong manual for information or instructions on installation, operation, inspection, maintenance, or parts.

Use only Harrington authorized replacement parts in the service and maintenance of this hoist.

WARNING

Equipment described herein is not designed for and **MUST NOT** be used for lifting, supporting, or transporting people, or for lifting or supporting loads over people.

Equipment described herein should not be used in conjunction with other equipment unless necessary and/or required safety devices applicable to the system, crane, or application are installed by the system designer, system manufacturer, crane manufacturer, installer, or user.

Modifications to upgrade, rerate, or otherwise alter this equipment shall be authorized only by the original equipment manufacturer.

Equipment described herein may be used in the design and manufacture of cranes or monorails. Additional equipment or devices may be required for the crane and monorail to comply with applicable crane design and safety standards. The crane designer, crane manufacturer, or user is responsible to furnish these additional items for compliance. Refer to ANSI/ASME B30.17, Safety Standard for Top-Running Single Girder Cranes; ANSI/ASME B30.2 Safety Standard for Top-Running Double-Girder Cranes; and ANSI/ASME B30.11 Safety Standard for Underhung Cranes and Monorails. If a below-the-hook lifting device or sling is used with a hoist, refer to ANSI/ASME B30.9, Safety Standard for Slings, or ANSI/ASME B30.20, Safety Standard for Below-the-Hook Lifting Devices.

Hoists and cranes used to handle hot molten material may require additional equipment or devices. Refer to ANSI Z241.2, Safety Requirements for Melting and Pouring of Metals in the Metalcasting Industry.

Failure to read and comply with any one of the limitations noted herein can result in serious bodily injury or death, and/or property damage.

NOTICE

It is the responsibility of the owner/user to install, inspect, test, maintain, and operate a hoist in accordance with ANSI/ASME B30.16, Safety Standard for Overhead Hoists and OSHA Regulations. If the hoist is installed as part of a total lifting system, such as an overhead crane or monorail, it is also the responsibility of the owner/user to comply with the applicable ANSI/ASME B30 volume that addresses that type of equipment.

It is the responsibility of the owner/user to have all personnel that will install, inspect, test, maintain, and operate a hoist read the contents of this manual and applicable portions of ANSI/ASME B30.16, "Safety Standard for Overhead Hoists", and OSHA Regulations. If the hoist is installed as part of a total lifting system, such as an overhead crane, the applicable ANSI/ASME B30 volume that addresses that type of equipment must also be read by all personnel.

If the hoist owner/user requires additional information, or if any information in the manual is not clear, contact Harrington or the distributor of the hoist. Do not install, inspect, test, maintain, or operate this hoist unless this information is fully understood.

A regular schedule of inspection of the hoist in accordance with the requirements of ANSI/ASME B30.16 should be established and records maintained.

1.2 Warning Tags and Labels

The End Trucks covered by this owner's manual may be used as part of a lifting system such as a crane. It is the responsibility of the supplier and the owner of such a lifting system to provide for and ensure that the lifting system be equipped with warning labels in accordance with applicable industry standards.

2.0 Technical Information

2.1 Specifications

- 2.1.1 Product Codes
- (a) HPC505 up to ½ Ton capacity
 - (b) HPC510 up to 1 Ton capacity
 - (c) HPC520 up to 2 Ton capacity

2.1.2 Description

The HPC500 Series End Truck Kit includes two 4-wheeled end trucks with rubber bumpers, bridge beam end stops, bridge beam fastener hardware, bridge beam assembly drawing, and this Owner’s Manual & Parts List. The HPC500 End Truck is designed to meet CMAA requirements for Class B Medium Duty Cranes. Its convertibility allows it to be assembled for either Top Running (TR) or Underhung (UH) cranes.

2.1.3 Dimensions

Refer to Table 2-1 and Figure 2-1 below.

Table 2-1 HPC500 End Truck Specifications & Dimensions (refer to Figure 2-1)												
Code	Max. Span (ft)	T Width of Flange or Rail Head (in)		D* (in)	H* End Truck Frame Spacing (in)	M* End Truck Frame Width (in)	N Runway Ctr. Line to Outer Edge of End Truck (in)	Q Wheel Tread Diameter (in)	X Width Beyond Span (in)	Y Wheel Running Surface to Bridge Beam (in)	R Wheel Running Surface to Bridge Beam (in)	End Truck Weight (lbs/pair)
		TR	UH									
HPC505	24	1.5 - 6	3 - 6	T + 4¾	T + 1¼	T + 7.3	M/2	3.12	10 - ½T	4.3	1.2	156
HPC510						T + 8.3		4.00		5.3	1.2	214
HPC520						3.3 - 6		4.88		5.9	1.1	270

* Formula shown is for S beams & ASCE rail. Add ¼ inch for W beams and rectangular bar.

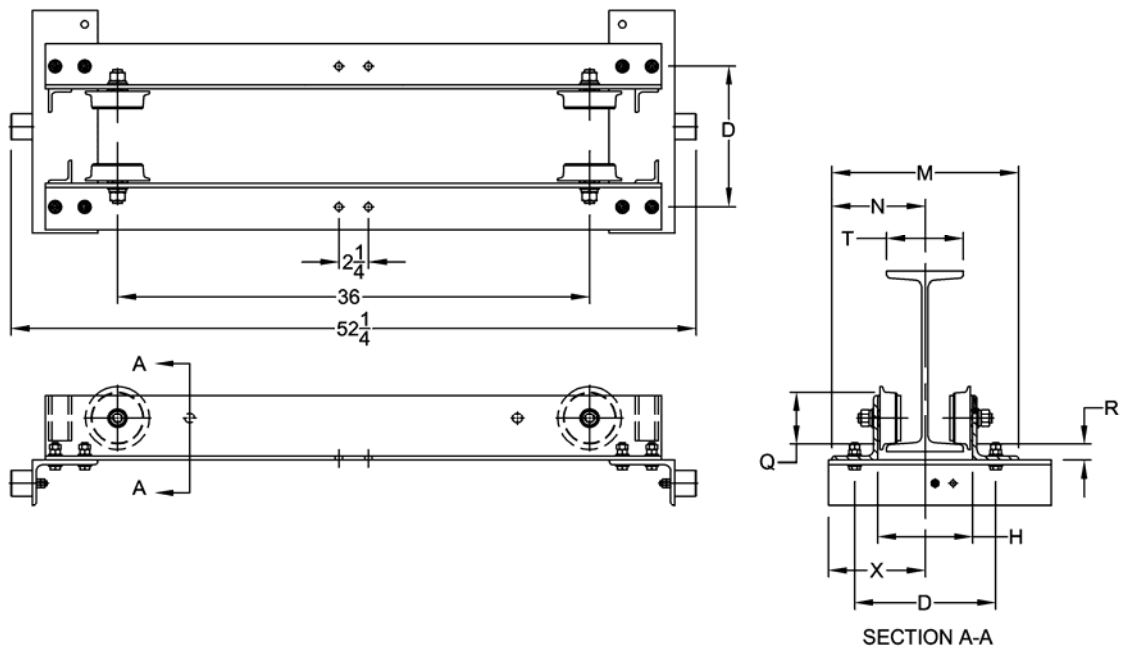

Underhung

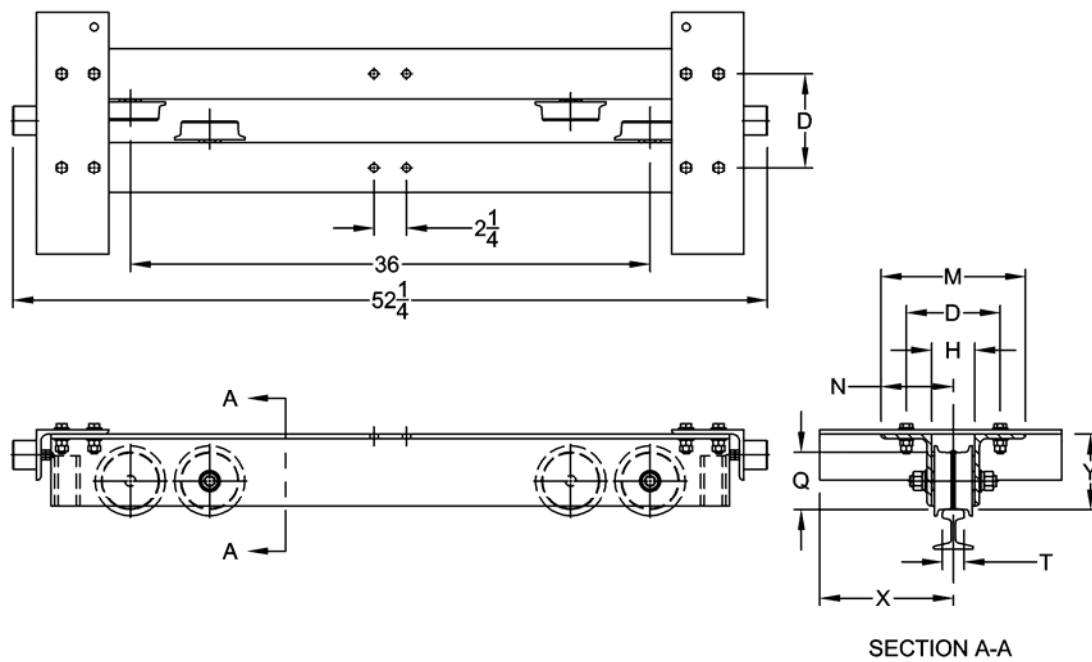

Top Running

Figure 2-1 HPC500 End Truck Dimensions (refer to Table 2-1)

2.2 Part Names

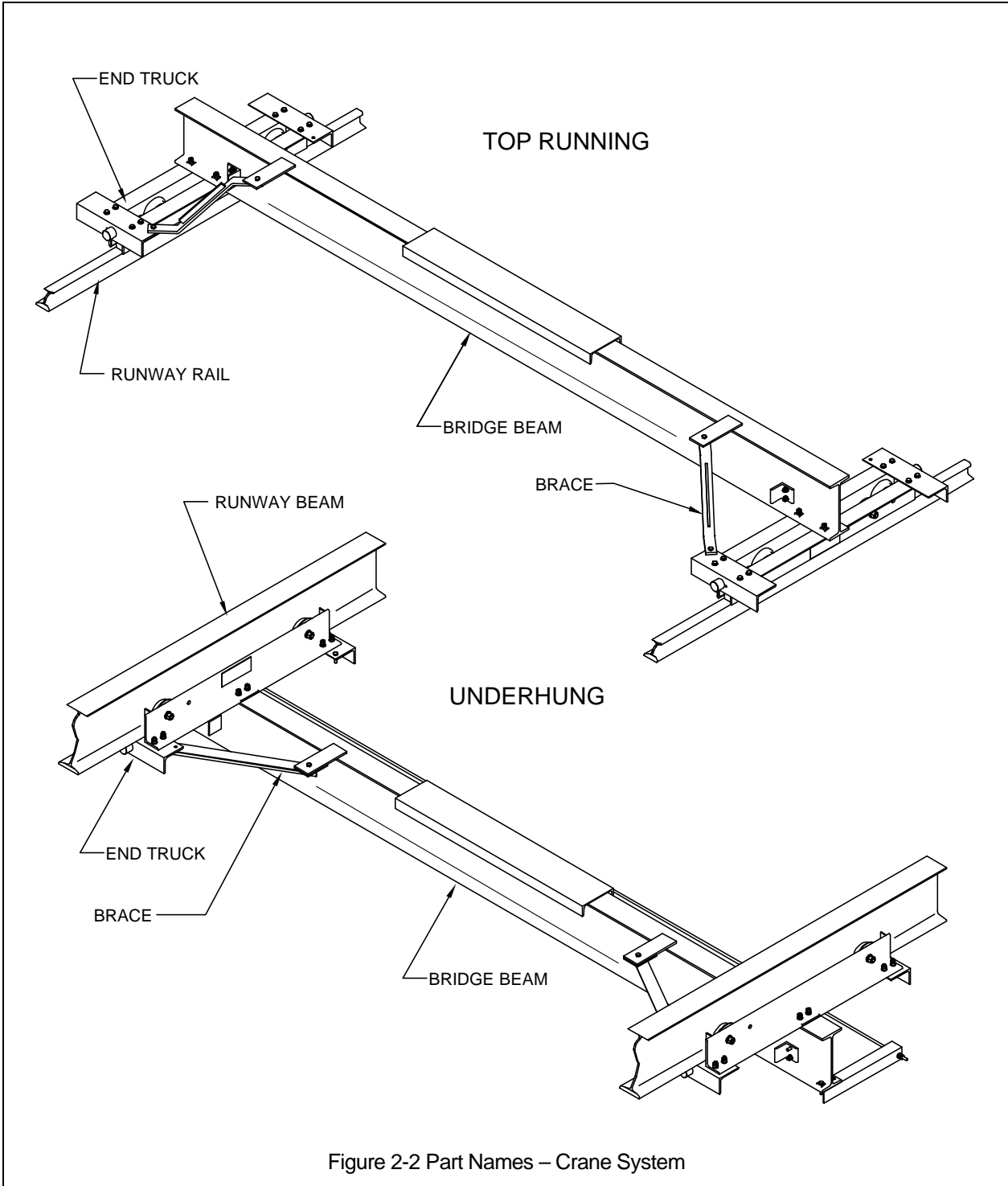

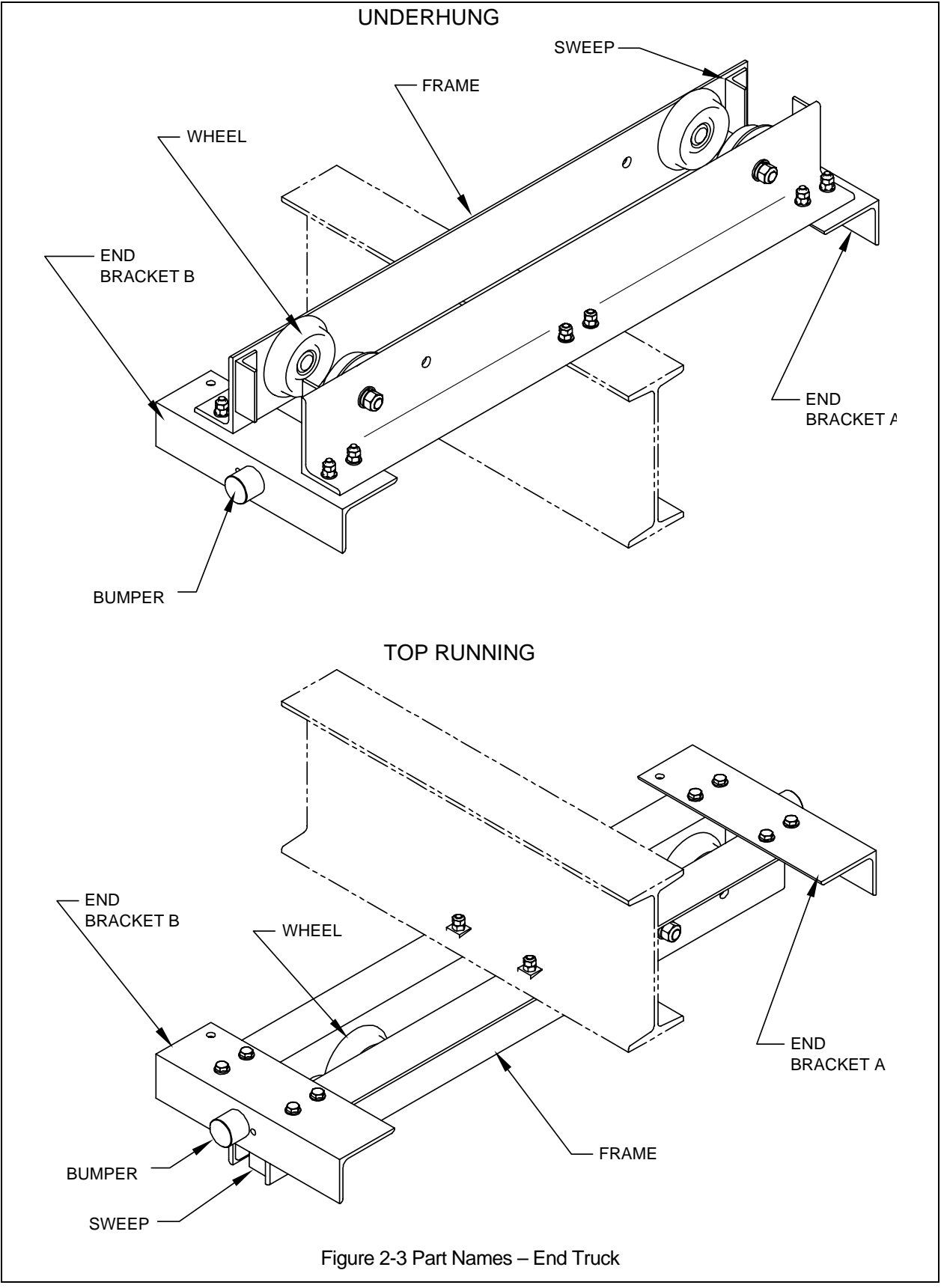

Figure 2-3 Part Names – End Truck

3.0 Pre - operational Procedures

3.1 Runway

3.1.1 **⚠WARNING** Crane systems must be intalled on runways that are properly designed, fabricated, installed, and supported. The runway must meet the requirements of CMAA Specification 74.

3.1.2 **NOTICE** Read through all steps completely before proceeding with installation.

3.1.3 **NOTICE** All operations associated with the assembly and installation of the end trucks and/or the crane system should be performed under the supervision of a Qualified Person (see Section 5 for the definition of Qualified Person).

3.1.4 Underhung – When HPC500 end trucks are assembled in the Underhung configuration, they are designed to fit runway beams as follows. If your runway beam does not meet these dimensional requirements, contact your supplier for help.

<u>End Truck</u>	<u>Beam Flange Width</u>	<u>Beam Depth</u>
HPC505	3 to 6 inches	≥ 5 inches
HPC510	3 to 6 inches	≥ 6 inches
HPC520	3.33 to 6 inches	≥ 8 inches

≥ means “greater than or equal to”

3.1.5 Top Running – When HPC500 end trucks are assembled in the Top Running configuration, they are designed to fit rail or square bar with a width between 1½ and 6 inches. Most commonly HPC500 end trucks set up for Top Running applications use any of the following sizes of ASCE Rail:: 25#, 30#, 35#, or 40#. Alternately, you can use any of the following sizes of square bar: 1½ inch, 1¾ inch, or 2 inch.

3.1.6 End Stops – The owner/installer must make sure that the runway beams are equipped with end stops to prevent the end trucks (or crane) from rolling off the end of the runway beams.

3.2 Bridge Beam

3.2.1 **NOTICE** Read through all steps completely before proceeding with installation.

3.2.2 **NOTICE** All operations associated with the assembly and installation of the end trucks and/or the crane system should be performed under the supervision of a Qualified Person (see Section 5 for the definition of Qualified Person).

3.2.3 Size – For the use of either a MANUAL or ELECTRIC HOIST on your HPC500 crane, use Table 3-1 to select the beam to use as the Bridge Beam.

Table 3-1 Bridge Beams for a **MANUAL** or **ELECTRIC HOIST** on an HPC500 Crane

Cap. (Tons)	Maximum Allowable Span (ft)			
	10	15	20	24
½	S8 X 18.4	S8 X 18.4	S8 X 18.4	S10 X 25.4
1	S8 X 18.4	S8 X 18.4	S10 X 25.4	S10 X 25.4
2	S10 X 25.4	S10 X 25.4	S12 X 31.8	S12 X 31.8 C8 X 11.5

3.2.4 Fabrication – Preparation of the Bridge Beam for assembly with the HPC500 End Trucks requires that holes be drilled in the beam as follows. Refer to Table 2-1 and Figure 2-1 for definitions of all letter variables used for dimensions. **NOTE** – For S6 beams mounting plates must be welded to the beam. Refer to the Bridge Beam Assembly Drawing (Underhung: Drawing. No. 62673; Top Running: Drawing. No. 62672) for details.

- **Underhung** – Drill eight 9/16” diameter holes through the top flange as shown in Figure 3-1. Drill four 9/16” diameter holes through the web as shown in Figure 3-2.
- **Top Running** – Drill eight 9/16” diameter holes through the bottom flange as shown in Figure 3-1. Drill four 9/16” diameter holes through the web as shown in Figure 3-3.

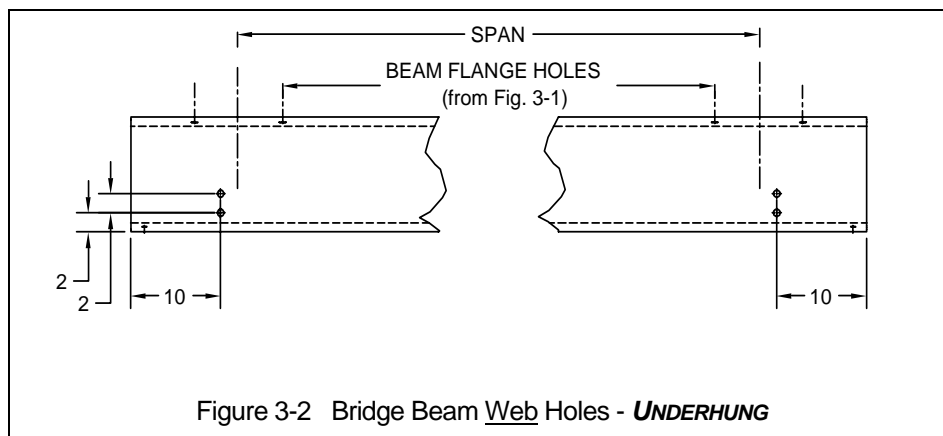
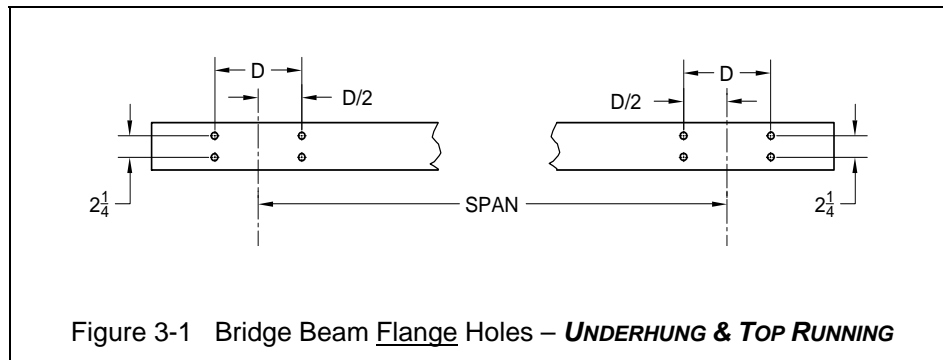

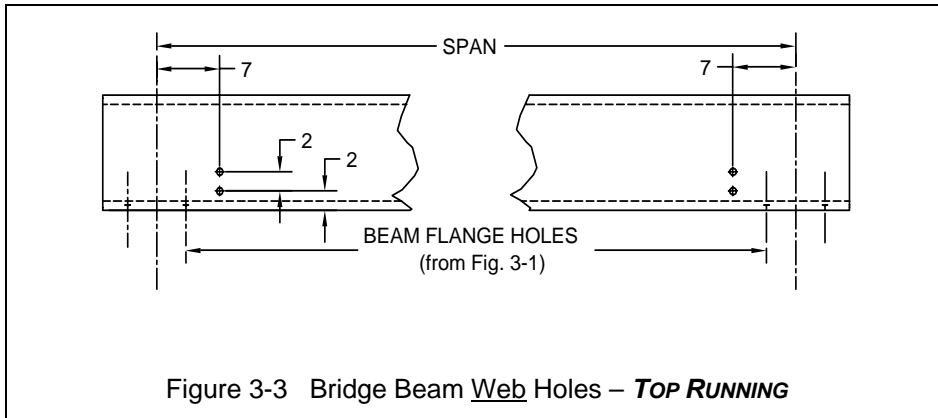

3.2.5 End Stop Installation – This step covers the installation of the end stops onto the bridge beam.

- Locate the holes that were installed in the web of the bridge beam (step 3.2.4 above). These are the holes for attaching the end stops to the bridge beam.
- Attach the four (4) end stops to the bridge beam in accordance with Figure 3-4. Fully tighten the fasteners by applying 75 ft-lb of torque.

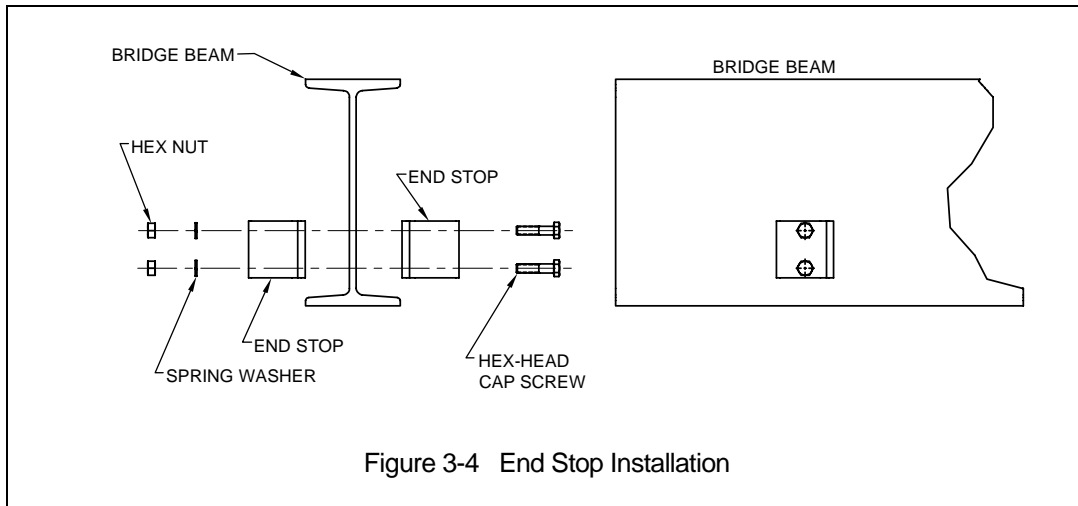

3.3 End Trucks

3.3.1 **NOTICE** Read through all steps completely before proceeding with installation.

3.3.2 **NOTICE** All operations associated with the assembly and installation of the end trucks and/or the crane system should be performed under the supervision of a Qualified Person (see Section 5 for the definition of Qualified Person).

3.3.3 End Bracket Preparation – Prior to assembling the end trucks prepare the four (4) end brackets (2 end brackets per end truck) as follows:

- **Measure** “T” for the runway that the end trucks will be installed on. For Underhung “T” is the flange width of the runway beam; for Top Running “T” is the width of the rail head or square bar (whichever is being used).
- **Drill** two 9/16” diameter holes in each of the four (4) end brackets in accordance with Figure 3-5.

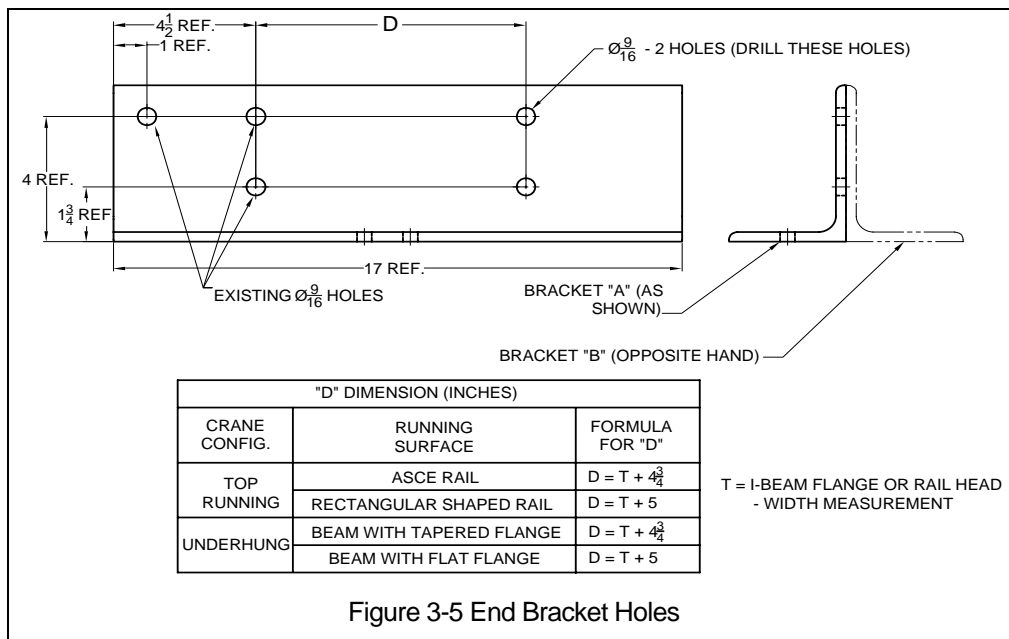
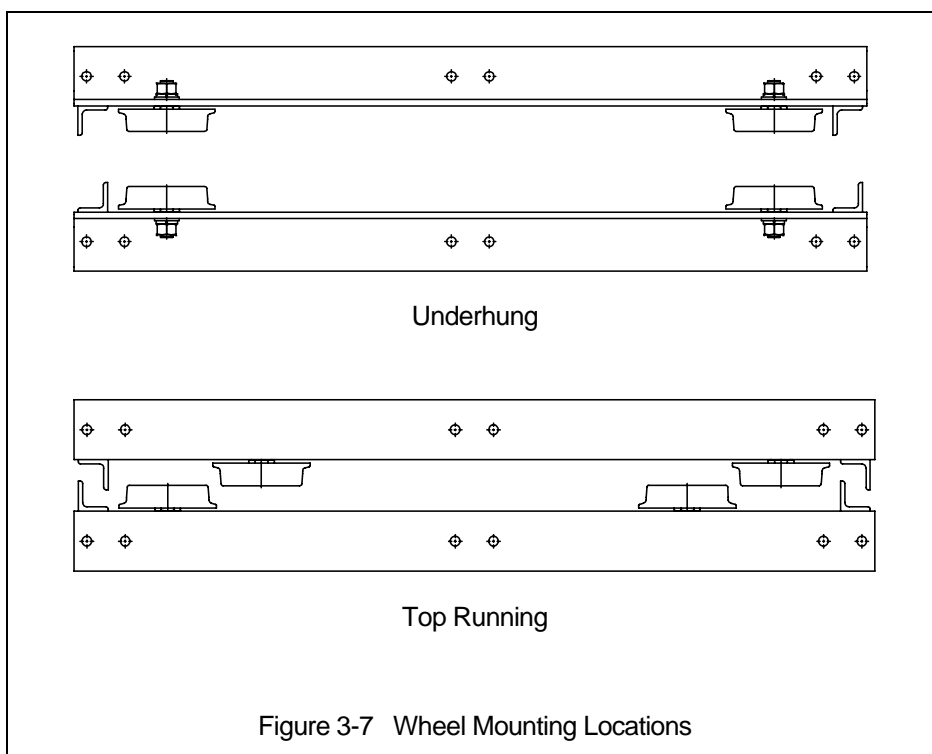
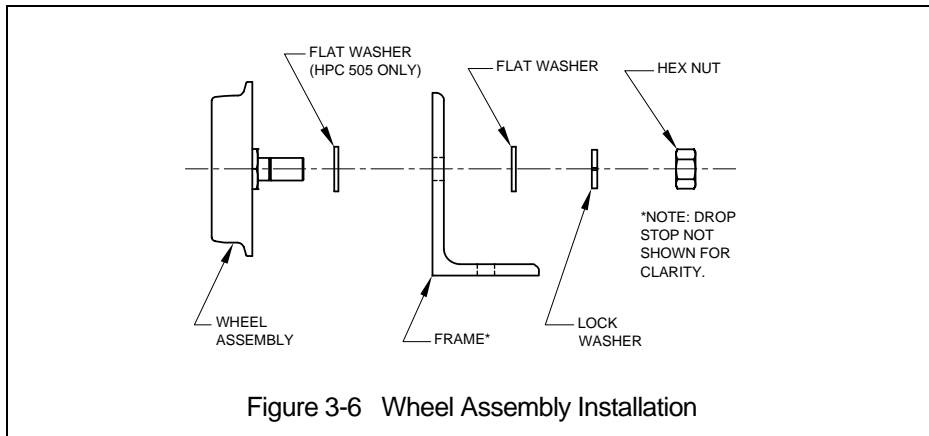

Figure 3-5 End Bracket Holes

3.3.4 Wheel Assembly Installation – Install the Wheel Assemblies to the end trucks as shown in Figure 3-6. Make sure you locate the Wheel Assemblies properly for your application (Underhung or Top Running) as shown in Figure 3-7. To prevent the axle from turning when tightening the hex nut, use an air-powered nut driver. Then, finalize the installation by applying torque to each wheel’s hex nut as follows.

- 75 ft-lb for HPC505
- 200 ft-lb for HPC510 and HPC520



3.3.5 Verify “H” Dimension – The “H” dimension is the End Truck Frame Spacing (see Table 2-1 and Figure 2-1). By verifying the “H” dimension you verify that the end bracket holes are correct for proper fit of the end truck onto the runway. Proceed as follows:

- Calculate the “H” dimension for your application. For S Beams and ASCE Rail $H = T + 1\frac{1}{4}$ (inches). For W Beams and Square Bar $H = T + 1\frac{1}{2}$ (inches). Note: T is the measurement from step 3.3.3 above.
- Refer to Figure 2-3 and Figure 3-9 and assemble the frames and end brackets together. As you tighten the fasteners (don’t fully tighten yet – this comes later) measure the actual “H” dimension in accordance with Figure 3-8. Verify that the measured “H” dimension and the calculated “H” dimension are the same.
- Match mark the end brackets to the frames to ensure the “H” dimension is held for the following steps.

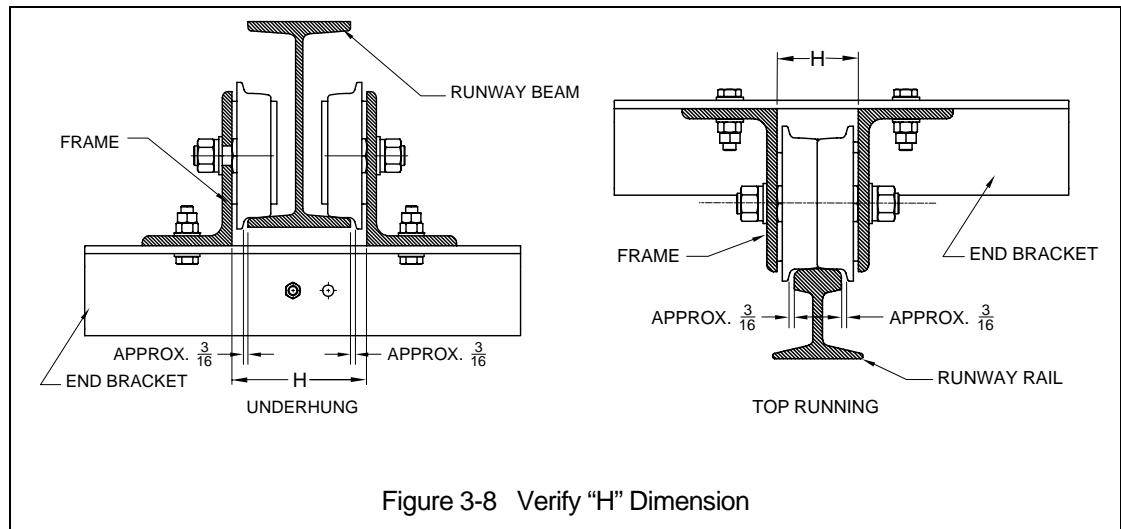

Figure 3-8 Verify "H" Dimension

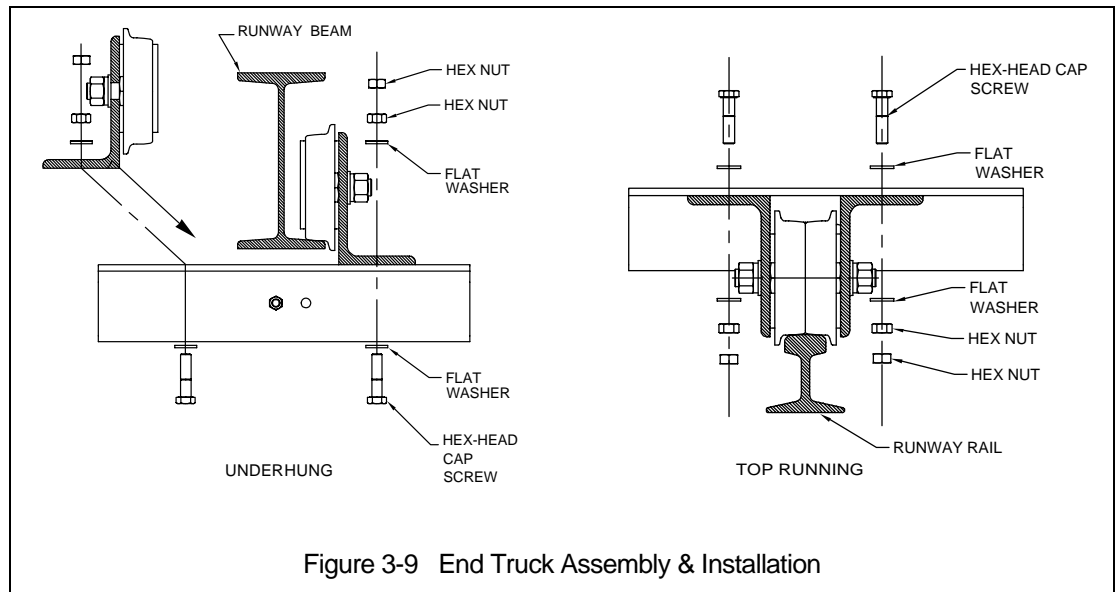

Figure 3-9 End Truck Assembly & Installation

3.3.6 End Truck Assembly & Installation – Here the assembly of the end trucks is completed and they are installed onto the runway. Orientation of the end trucks on the runway is important. Make sure you put each end truck onto the runway so that the hole in the end bracket for the brace is on the inside of the runway (see Figure 2-2).

■ Underhung – apply the following steps for each end truck:

- Disassemble a frame from the end truck.
- Place the frame with the end brackets still attached to it onto the runway beam so its wheels ride on the lower flange of the runway beam in accordance with the Underhung part of Figure 3-9.
- In the same manner place the other frame on the opposite side of the runway beam and reassemble this frame to the end brackets, again in accordance with the Underhung part of Figure 3-9.

- Ensure that the “H” dimension is correct as determined in step 3.3.5 above, and tighten the fasteners by applying 75 ft-lb of torque.
- **Top Running** – apply the following steps for each end truck:
 - Ensure that the “H” dimension is correct as determined in step 3.3.5 above, and tighten the fasteners by applying 75 ft-lb of torque.
 - Place the end truck onto the runway rail (or square bar) in accordance with the Top Running part of Figure 3-8.
 - Since the end truck will not stay balanced on the runway in this condition, temporarily support it so that it stays safely balanced in position until the bridge beam is installed.

3.3.7 Bridge Beam Installation – This step covers the installation of the bridge beam onto the end trucks.

- **Underhung** – As shown in Figure 2-2 for Underhung cranes, the bridge beam is attached to the under side of the end trucks.
 - Attach the bridge beam to the under side of the end trucks in accordance with the Underhung part of Figure 3-10. Do not yet fully tighten the fasteners.
 - Ensure the crane is square in accordance with Figure 3-11 and proceed to fully tighten the fasteners by applying 75 ft-lb of torque.
- **Top Running** – As shown in Figure 2-2 for Top Running cranes, the bridge beam is attached to the upper side of the end trucks.
 - Attach the bridge beam to the upper side of the end trucks in accordance with the Top Running part of Figure 3-10. Do not yet fully tighten the fasteners.
 - Ensure the crane is square in accordance with Figure 3-11 and proceed to fully tighten the fasteners by applying 75 ft-lb of torque.

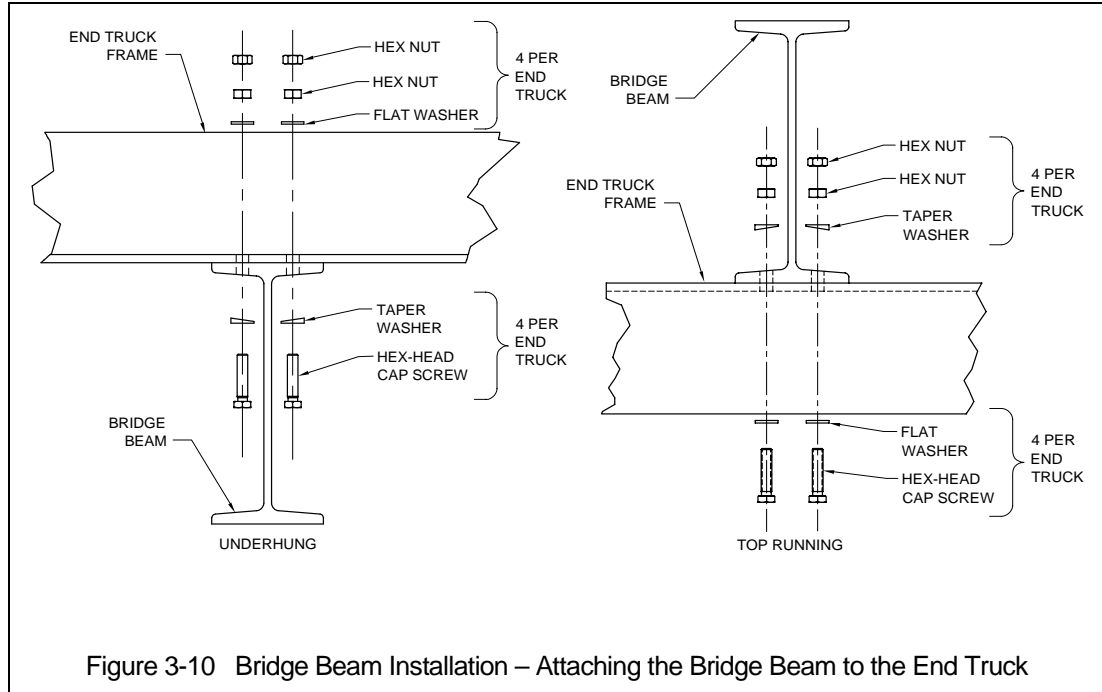

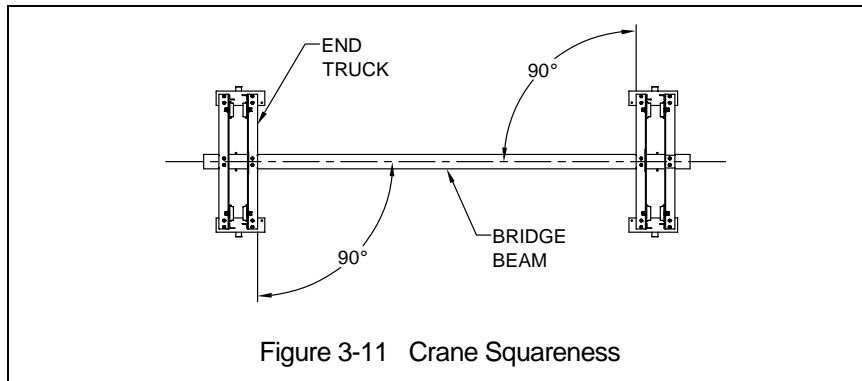

3.4 Pre-operational Checks and Trial Operation

- 3.4.1 Record the end trucks' Code and Serial No. from the nameplate (see Figure 10-1) in the space provided on the cover of this manual.
- 3.4.2 Ensure that the end trucks are properly installed on the runway beams/rails.
- 3.4.3 If the end trucks are used as part of an overhead travelling bridge crane, then make sure that the bridge beam is properly designed, fabricated, and installed.
- 3.4.4 If a hoist/trolley is used in the system:
- Ensure the hoist/trolley is properly installed in accordance with the manufacturer's requirements and recommendations.
 - Ensure that the end stops on the bridge beam for the trolley motion are installed correctly and securely.
- 3.4.5 Prepare for Trial Operation
- Before operating become familiar with operating the equipment (see Section 4 – Operation).
 - If a hoist/trolley is used in the system, perform pre-operational checks in accordance with the manufacturer's requirements and recommendations.
- 3.4.6 Trial Operation
- If the end trucks are used as part of an overhead travelling bridge crane, then move the crane along the entire length of the runway. Ensure that the crane has proper clearance from obstructions. Check for proper alignment and clearances of the crane and the end trucks to the runway (refer to Figure 3-8 and Figure 3-11). Adjust as necessary. Make sure that after any adjustments the fasteners are properly secured and tightened.
 - Perform inspections in accordance with Section 5.3, "Frequent Inspections".
 - If a hoist/trolley is used in the system, perform trial operation in accordance with the manufacturer's requirements and recommendations.
- 3.4.7 Load Test – perform a load test in accordance with ASME B30.11, "Monorails and Underhung Cranes", or ASME B30.17, "Overhead and Gantry Cranes (Top Running Bridge, Single Girder, Underhung Hoist)", whichever applies.

4.0 Operation

4.1 Introduction

Specific operation instructions are not provided herein because the HPC500 series end trucks are used in systems not covered by this Owner's Manual. Nevertheless, operation of systems using the HPC500 end trucks is an **EXTREMELY IMPORTANT** issue – following is important information about operation.

4.2 Important Information About Operation

⚠ DANGER Do not walk under a suspended load.

⚠ WARNING Do not use HPC500 end trucks in systems that lift, support, or transport people.

⚠ WARNING Operators shall read materials pertaining to the operation of the equipment. For systems using the HPC500 series end trucks, the supplier and/or owner of the system is/are responsible for providing information for use by the operator for the safe operation of the system. Sources for such materials include:

- Manufacturer – If a hoist/trolley (or some other type of equipment) is used in the system, then the manufacturer should provide materials for the operation of the hoist/trolley (or other equipment).
- CMAA – The Crane Manufacturer's Association of America (CMAA) publishes a Crane Operator's Manual. Contact the CMAA at (704) 676-1190 or www.mhia.org/cmaa.
- HMI – The Hoist Manufacturer's Institute (HMI) publishes a Hoist Operator's Manual. Contact the HMI at (704) 676-1190 or www.mhia.org/hmi.
- ASME – The American Society of Mechanical Engineers publishes safety standards pertaining to the type of equipment that could be used in a system with the HPC500 end trucks. Examples are listed below. Contact the ASME at (800) 843-2763 or www.asme.org.
 - ASME B30.11, "Monorails and Underhung Cranes"
 - ASME B30.16, "Overhead Hoists (Underhung)"
 - ASME B30.17, "Overhead and Gantry Cranes (Top Running Bridge, Single Girder, Underhung Hoist)"
- Labels – Labels attached to equipment used in systems provide information important to the safe operation of the equipment.

⚠ WARNING Operators should be trained to be aware of potential malfunctions of the equipment that require adjustment or repair, and to be instructed to stop operation if such malfunctions occur, and to immediately advise their supervisor so corrective action can be taken.

⚠ WARNING Operators should have normal depth perception, field of vision, reaction time, manual dexterity, and coordination.

⚠ WARNING Operators should not have a history of, or be prone to seizures, loss of physical control, physical defects, or emotional instability that could result in actions of the operator being a hazard to the operator or others.

⚠ WARNING Operators should not operate equipment when under the influence of alcohol, drugs, or medication.

⚠ WARNING Improper operation of systems using the HPC500 end trucks can create a potentially hazardous situation which, if not avoided, could result in death or serious injury, and substantial property damage. To avoid such a potentially hazardous situation the operator shall be familiar with, and shall obey, the operating requirements and guidelines for the system.

5.0 Inspection

5.1 General

5.1.1 The inspection instructions herein are limited to the HPC500 Series End Trucks and Harrington-designed HPC500 Cranes, and are based on the use of these products for overhead cranes and monorails as defined by the following standards.

- **ANSI/ASME B30.11** **Monorails and Underhung Cranes**
- **ANSI/ASME B30.16** **Overhead Hoists (Underhung)**
- **ANSI/ASME B30.17** **Overhead and Gantry Cranes (Top Running Bridge, Single Girder, Underhung Hoist)**

NOTICE For systems that are not addressed by these standards, the appropriate inspection should be determined and overseen by a Qualified Person (see definition below).

5.1.2 The following definitions are from the standards listed in Section 5.1.1 above:

- **Designated Person** - a person selected or assigned as being competent to perform the specific duties to which he/she is assigned.
- **Qualified Person** - a person who, by possession of a recognized degree or certificate of professional standing, or who, by extensive knowledge, training, and experience, has successfully demonstrated the ability to solve or resolve problems relating to the subject matter and work.
- **Normal Service** - service which involves operating at less than a certain percentage of rated load and less than a specified frequency. Refer to the applicable ANSI/ASME B30 standards for the specific definition for your application.
- **Heavy Service** - that service which involves operation within the rated load limit which exceeds normal service.
- **Severe Service** - that service which involves normal or heavy service with abnormal operating conditions.

5.2 Inspection Classification

5.2.1 Initial Inspection – Prior to initial use, a Designated Person shall inspect the equipment to verify compliance with the applicable provisions of this manual.

5.2.2 Inspection Intervals – Inspections are divided into two general classifications based upon the intervals at which inspection should be performed. The intervals in turn are dependent upon the nature of the critical components and the degree of their exposure to wear, deterioration, or malfunction. The two general classifications are designated as **FREQUENT** and **PERIODIC**, with respective intervals between inspections as defined below.

5.2.3 **FREQUENT** Inspection – Visual examinations by the operator or other Designated Person with intervals per the following criteria:

- Normal service - monthly
- Heavy service - weekly to monthly
- Severe service - daily to weekly
- Special or Infrequent Service – as recommended by a Qualified Person

5.2.4 **PERIODIC** Inspection – Visual inspection by a Designated Person with intervals per the following criteria:

- Normal service - yearly
- Heavy service - semiannually

- Severe service - quarterly
- Special or Infrequent Service – as recommended by a Qualified Person

5.3 Frequent Inspection

5.3.1 Use the following as guidance for inspections to be made on a **FREQUENT** basis.

- Inspect all functional operating mechanisms for:
 - Proper Operation
 - Proper Adjustment
 - Unusual Sounds
- If a hoist/trolley is included in the system, perform inspection in accordance with the manufacturer's recommendations for **FREQUENT** inspection.
- Continually observe during operation. Any defects or damage must be reported and shall be evaluated and resolved by a Designated Person such that the equipment is maintained in safe working condition.

5.4 Periodic Inspection

5.4.1 Use the following as guidance for inspections to be made on a **PERIODIC** basis.

- Inspect in accordance with Table 5-1.
- Results of **PERIODIC** inspections must be reported and shall be evaluated and resolved by a Designated Person such that the equipment is maintained in safe working condition.

Table 5-1 Periodic Inspection
Requirements of frequent inspection.
Deformed, cracked or corroded members
Loose or missing bolts, nuts, pins or rivets.
Worn, cracked, or distorted parts such as pins, bearings, wheels, shafts, gears, rollers, locking and clamping devices, bumpers, stops, and wheel running surfaces (rail or flange).
Function, instruction, and warning labels for legibility and replacement.
If a hoist/trolley is included in the system, perform inspection in accordance with the manufacturer's recommendations for PERIODIC inspection.

5.5 Occasionally Used End Trucks and Cranes

- 5.5.1 End Trucks and cranes that are used infrequently shall be inspected as follows prior to placing in service:
- Idle More Than 1 Month, Less Than 1 Year: Inspect per **FREQUENT** Inspection criteria of Section 5.3 above.
 - Idle More Than 1 Year: Inspect per **PERIODIC** Inspection criteria of Section 5.4 above.

5.6 Inspection Records

Dated inspection reports and records should be maintained for **PERIODIC** inspections. These records should be stored where they are available to personnel involved with the inspection, maintenance, or operation of the equipment.

5.7 Inspection Methods and Criteria

- 5.7.1 This section covers the inspection of specific items. In accordance with the standards listed in paragraph 5.1 above, these inspections are not intended to involve disassembly. Rather, disassembly for further inspection would be required if **FREQUENT** or **PERIODIC** inspection results so indicate. Only a Qualified Person trained in the disassembly and re-assembly of the equipment should perform such disassembly and further inspection.
- 5.7.2 Table 5-2 below gives Methods, Criteria, and Corrective Action for the inspection of components of HPC500 End Trucks and Cranes.

Table 5-2 Inspections Methods and Criteria

Component	Item	Method	Criteria	Corrective Action
Runway	Fasteners	Check tightness Measure torque	Fasteners must be sufficiently tight. Refer to torque values listed in Section 3.	Tighten
	Wheel Running Surfaces	Visual	The surfaces on which the end truck wheels run must be free of oil, grease or paint.	Clean/remove contaminants
	Wheel Running Surfaces	Visual	The surfaces on which the end truck wheels run must not be worn excessively.	Replace.
	Dimensions	Measure	The span, straightness, elevation must be within allowed tolerances as specified by CMAA Spec. 74.	Adjust/repair
Bridge Beam	Bridge Beam	Visual Measure	The beam must not be deformed or damaged.	Repair or replace
	Welded parts	Visual NDT	Welds to be in accordance with weld specifications of CMAA Spec. 74.	Repair
	Lower Flange	Visual	The travel surface must not be worn excessively.	Replace
	Fasteners	Check tightness Measure torque	Fasteners must be sufficiently tight. Refer to torque values listed in Section 3.	Tighten
	Deflection	Measure	Deflection at mid-span under rated load must be less than 1/600 of the span.	Repair , replace, or down-rate
	Capacity Label(s)	Visual	Label(s) must be legible and securely attached.	Repair or replace
End Truck	Wheel Tread	Measure	Wheel diameter must not be less than the "Min. Value for Replacement" listed in Table 5-3.	Replace
	Wheel Flange	Visual	Wheel flange must not be worn excessively.	Replace
	Fasteners	Check tightness Measure torque	Fasteners must be sufficiently tight. Refer to torque values listed in Section 3.	Tighten

Table 5-3 Wheel Tread Diameter

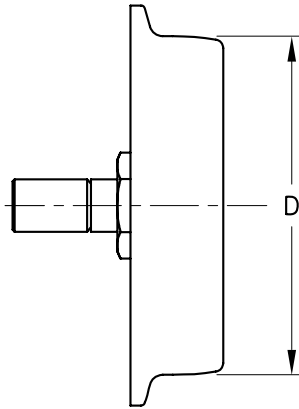

End Truck Code	Standard Value (in)	Min. Value for Replacement (in)
HPC505	3.12	2.97
HPC510	4.00	3.81
HPC520	4.88	4.66

6.0 Lubrication

6.1 HPC500 End Trucks

6.1.1 There are no lubrication requirements for the HPC500 Series End Trucks for the following reasons.

- The wheel bearings are sealed and permanently lubricated.
- There are no other components that are lubricated or which require lubrication.

6.2 Other Equipment

6.2.1 If a hoist/trolley (or some other type of equipment) is used in the system, then perform lubrication of the hoist/trolley (or other equipment) in accordance with the manufacturer's requirements and recommendations.

7.0 Maintenance and Handling

7.1 General

7.1.1 The HPC500 Series End Truck is designed to be ***MAINTENANCE-FREE***.

If a hoist/trolley (or some other type of equipment) is used in the system, then perform maintenance and handling of the hoist/trolley (or other equipment) in accordance with the manufacturer's requirements and recommendations.

7.2 Storage

7.2.1 Whenever the end trucks are to be placed into storage, place extra grease onto all exposed unpainted parts such as the wheels and fasteners. Make certain that no debris or moisture is allowed to accumulate on the end truck.

7.2.2 The storage location should be clean and dry.

7.3 Outdoor Installations

For outdoor installations the HPC500 Series End Trucks should be protected from the weather when not in use.

8.0 Troubleshooting

Use Table 8-1, “Troubleshooting Guide” below to troubleshoot any problems you may encounter with the HPC500 Series End Truck or Crane.

Table 8-1 Troubleshooting Guide		
Trouble	Cause	Remedy
End Trucks do not move smoothly along the runway	Runway system is out of tolerance	<p>Make sure the span of the runway system is within the allowable tolerance of CMAA Spec 74.</p> <p>Make sure the straightness of each runway is within the allowable tolerance of CMAA Spec 74.</p> <p>Make sure the elevation of each runway is within the allowable tolerance of CMAA Spec 74.</p> <p>Make sure that each runway is at the same elevation within the allowable tolerance of CMAA Spec 74.</p>
	Span of the crane does not match the span of the runway system	Adjust to make the spans match.
	The crane is not square	Adjust to make the crane square – see Section 3.3.
	Damaged end truck wheel(s)	Replace damage wheel(s).
End Trucks’ bumpers do not contact the runway end stops simultaneously	The crane is not square	Adjust to make the crane square – see Section 3.3.
	The end stops are not located correctly on the runways.	Relocate the end stops on the runway to their correct locations.

9.0 Warranty

Warranty explanation and terms.

All products sold by Harrington Hoists, Inc. are warranted to be free from defects in material and workmanship from date of shipment by Harrington for the following periods:

Manual Hoists & Trolleys - 2 years

Air and Electric Powered Hoists, Trolleys, and Crane Components - 1 year

Spare / Replacement Parts - 1 year

The product must be used in accordance with manufacturer's recommendations and must not have been subject to abuse, lack of maintenance, misuse, negligence, or unauthorized repairs or alterations.

Should any defect in material or workmanship occur during the above time period in any product, as determined by Harrington Hoist's inspection of the product, Harrington Hoists, Inc. agrees, at its discretion, either to replace (not including installation) or repair the part or product free of charge and deliver said item F.O.B. Harrington Hoists, Inc. place of business to customer.

Customer must obtain a Return Goods Authorization as directed by Harrington or Harrington's published repair center prior to shipping product for warranty evaluation. An explanation of the complaint must accompany the product. Product must be returned freight prepaid. Upon repair, the product will be covered for the remainder of the original warranty period. If it is determined there is no defect, or that the defect resulted from causes not within the scope of Harrington's warranty, the customer will be responsible for the costs of returning the product.

Harrington Hoists, Inc. disclaims any and all other warranties of any kind expressed or implied as to the product's merchantability or fitness for a particular application. Harrington will not be liable for death, injuries to persons or property or for incidental, contingent, special or consequential damages, loss or expense arising in connection with the use or inability whatever, regardless of whether damage, loss or expense results from any act or failure to act by Harrington, whether negligent or willful, or from any other reason.

10.0 Parts List

When ordering Parts, please provide the Code number located on the end truck nameplate (see Figure 10-1 below).

Reminder: Per Sections 1.1 and 3.4.1, to aid in ordering Parts and Product Support, record the end trucks' Code and Serial No. in the space provided on the cover of this manual.

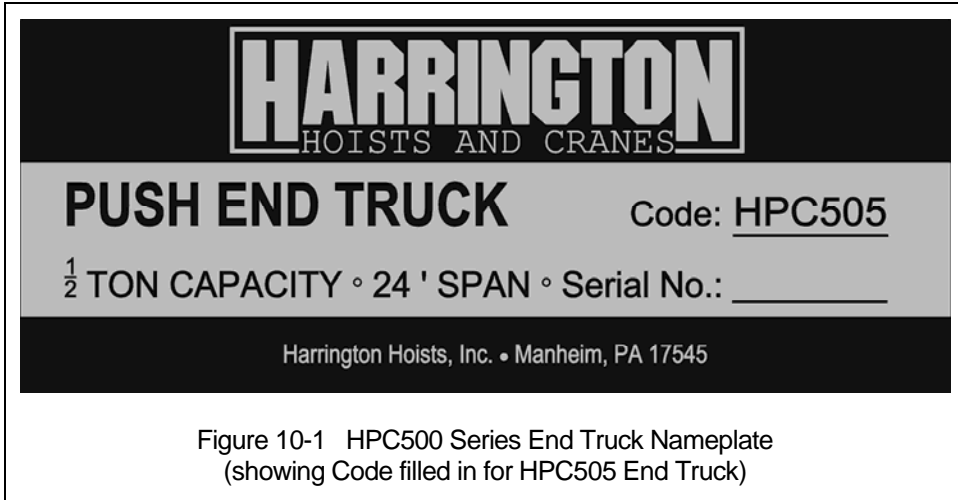

Figure 10-1 HPC500 Series End Truck Nameplate
(showing Code filled in for HPC505 End Truck)

Table 10-1 Parts List for HPC500 Series End Trucks

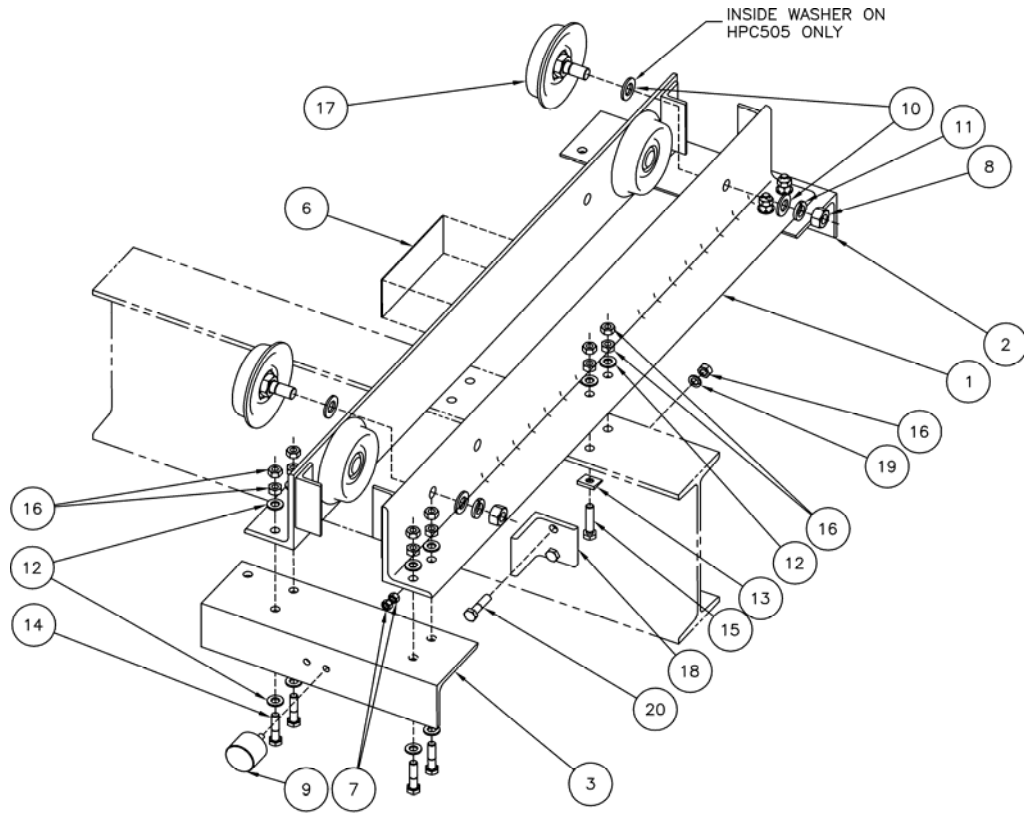

Figure Number	Qty/Pr	HPC505	HPC510	HPC520	PART NAME
1	4	52391	52390	62674	Frame Assembly
2	2		62675		End Bracket A – Standard Flange Range
			62678		End Bracket A – Extended Flange Range
3	2		62676		End Bracket B – Standard Flange Range
			62679		End Bracket B – Extended Flange Range
6	2	80065	80066	80067	Name Plate
7	8		9003903		Nut
8	8	9003905		9003908	Nut
9	4		9004603		Bumper
10	16	9005209			Flat Washer
	8			9005212	
11	8	9005313		9005317	Lock Washer
12	40		9012515		Flat Washer
13	8		9043514		Tapered Washer
14	16		9093374		Bolt
15	8		9093376		Bolt
16	52		9093433		Nut
17	8	9200011	9200012	9200013	Wheel Assembly
18	4		6245909		End Stop
19	4		9012713		Spring Washer
20	4		9093146		Bolt

NOTES

NOTES



www.harringtonhoists.com

Harrington Hoists, Inc.
401 West End Avenue
Manheim, PA 17545
Phone: 717-665-2000
Toll Free: 800-233-3010
Fax: 717-665-2861

Harrington Hoists - Western Division
2341 Pomona Rd. #103
Corona, CA 92880-6973
Phone: 951-279-7100
Toll Free: 800-317-7111
Fax: 951-279-7500

HPC500OM