

# Explosion Proof Cable Reels Series 1500

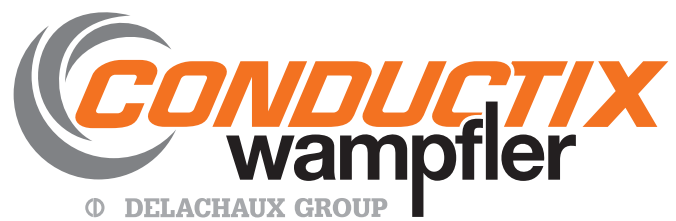
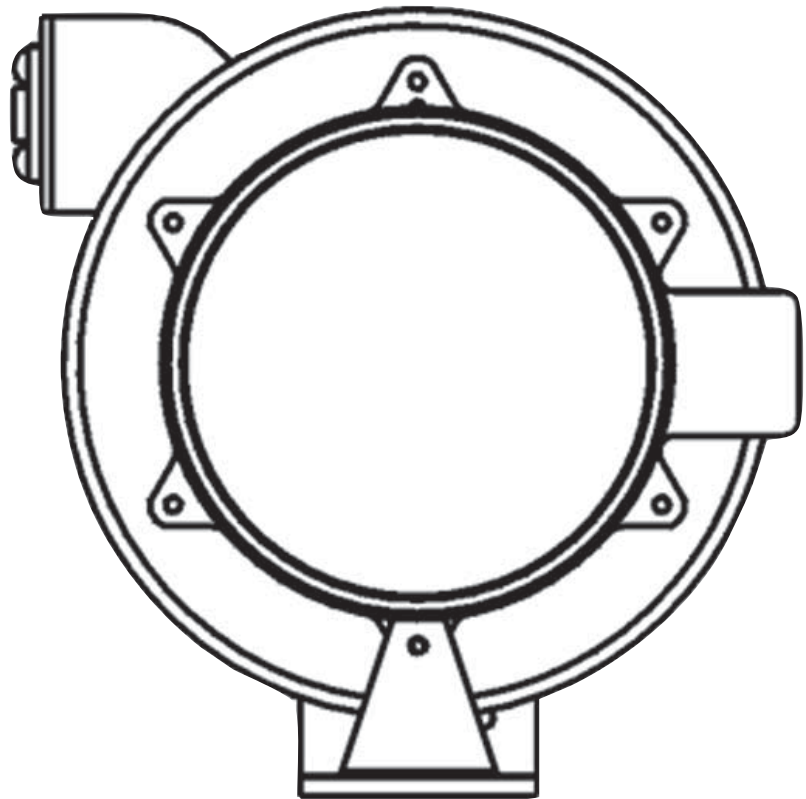

# Conductix Incorporated

The technical data and images which appear in this manual are for informational purposes only. **NO WARRANTIES, EXPRESS OR IMPLIED, INCLUDING WARRANTIES OF MERCHANTABILITY OR FITNESS FOR A PARTICULAR PURPOSE, ARE CREATED BY THE DESCRIPTIONS AND DEPICTIONS OF THE PRODUCTS SHOWN IN THIS MANUAL.** Conductix makes no warranty (and assumes no liability) as to function of equipment or operation of systems built according to customer design or of the ability of any of its products to interface, operate or function with any portions of customer systems not provided by Conductix.

Seller agrees to repair or exchange the goods sold hereunder necessitated by reason of defective workmanship and material discovered and reported to Seller within one year after shipment of such goods to Buyer.

Except where the nature of the defect is such that it is appropriate, in Seller's judgment, to effect repairs on site, Seller's obligation hereunder to remedy defects shall be limited to repairing or replacing (at Seller's option) FOB point of original shipment by Seller, any part returned to Seller at the risk and cost of Buyer. Defective parts replaced by Seller shall become the property of Seller.

Seller shall only be obligated to make such repair or replacement if the goods have been used by Buyer only in service recommended by Seller and altered only as authorized by Seller. Seller is not responsible for defects which arise from improper installation, neglect, or improper use or from normal wear and tear.

Additionally, Seller's obligation shall be limited by the manufacturer's warranty (and is not further warranted by Seller) for all parts procured from others according to published data, specifications or performance information not designed by or for Seller.

Seller further agrees to replace or at Seller's option to provide a refund of the sales price of any goods that do not conform to applicable specifications or which differ from that agreed to be supplied which non-conformity is discovered and forthwith reported to Seller within thirty (30) days after shipment to the Buyer. Seller's obligation to replace or refund the purchase price for non-conforming goods shall arise once Buyer returns such goods FOB point of original shipment by Seller at the risk and cost of Buyer. Goods replaced by Seller shall become the property of Seller.

There is no guarantee or warranty as to anything made or sold by Seller, or any services performed, except as to title and freedom from encumbrances and, except as herein expressly stated and particularly, and without limiting the foregoing, **there is no guarantee or warranty, express or implied, of merchantability or of fitness for any particular purpose or against claim of infringement or the like.**

Seller makes no warranty (and assumes no liability) as to function of equipment or operation of systems built to Buyer's design or of the ability of any goods to interface, operate or function with any portions of Buyer's system not provided by Seller.

Seller's liability on any claim, whether in contract, tort (including negligence), or otherwise, for any loss or damage arising out of, connected with, or resulting from the manufacture, sale, delivery, resale, repair, replacement or use of any products or services shall in no case exceed the price paid for the product or services or any part thereof which give rise to the claim. In no event shall Seller be liable for consequential, special, incidental or other damages, nor shall Seller be liable in respect of personal injury or damage to property not the subject matter hereof unless attributable to gross misconduct of Seller, which shall mean an act or omission by Seller demonstrating reckless disregard of the foreseeable consequences thereof.

Seller is not responsible for incorrect choice of models or where products are used in excess of their rated and recommended capacities and design functions or under abnormal conditions. Seller assumes no liability for loss of time, damage or injuries to property or persons resulting from the use of Seller's products. Buyer shall hold Seller harmless from all liability, claims, suits and expenses in connection with loss or damage resulting from operation of products or utilization of services, respectively, of Seller and shall defend any suit or action which might arise there from in Buyer's name - provided that Seller shall have the right to elect to defend any such suit or action for the account of Buyer. The foregoing shall be the exclusive remedies of the Buyer and all persons and entitles claiming through the Buyer.

## 1.0 Safety Instructions

- 1.1 Electrical Warnings
- 1.2 Operational Warnings
- 1.3 Maintenance Warnings
- 1.4 Electrical Ratings
- 1.5 Labels and Markings

## 2.0 Installation

- 2.1 Application Types
- 2.2 Mounting (w/ or w/o pivot base)
- 2.3 Roller Guide
- 2.4 Ratchet
- 2.5 Cable Installation
- 2.6 Spring Tension Adjustment
- 2.7 Power Connections

## 3.0 Operation

## 4.0 Maintenance

- 4.1 Maintenance Warning
- 4.2 Lubrication
- 4.3 Inspections
- 4.4 Slip Ring Replacement
- 4.5 Cable Replacement
- 4.6 Spring Motor Replacement

## 5.0 Troubleshooting

## 6.0 Replacement Parts

### RECORD

The catalog number of the reel and the serial number of the reel are required when ordering replacement parts or discussing the reel with the factory. Please record this information now in the spaces provided below.

CATALOG NO. OF REEL \_\_\_\_\_

DESCRIPTION NO. OF REEL \_\_\_\_\_

SERIAL NO. \_\_\_\_\_

DATE INSTALLED \_\_\_\_\_

# 1.0 Safety

## 1.1 Electrical Warnings

- 1.1.1 Properly ground equipment before use in accordance with both the National Electric Code and local electrical codes and ordinances.
- 1.1.2 Disconnect electrical power from the cable reel before any service functions are performed.
- 1.1.3 Do not use this cable reel for loads greater than the current rating listed on the label and voltage greater than 600V. The ampacity (current) rating of the cable must be in accordance with the National Electric Code.
- 1.1.4 Electrical wiring on the reel must be done by a qualified electrician.

## 1.2 Operational Warnings

- 1.2.1 Exercise care when handling the cable reel during normal operation. This cable reel has a rotating spool powered by springs under tension.
- 1.2.3 **Do not disassemble the spring motor for any reason.** Serious personal injury could result. This cable reel is equipped with springs under tension. Contact the factory for assistance:

**In the U.S. call: 1-800-521-4888**

**In Canada call: 1-800-667-2487**

## 1.3 Maintenance Warnings

- 1.3.1 Do not use cable different from that for which the reel is intended. Changes in diameter, weight per foot, length of cable or flexibility will affect the operation of the reel.
- 1.3.2 Mounting hardware and fasteners should be installed to maintain tightness under vibration and checked periodically to assure tightness.
- 1.3.3 Overhead installation mountings should be such that the reel is not suspended by bolts in tension. A safety chain or cable is strongly recommended to minimize damage and/or possible injury in the event of mounting failure.
- 1.3.4 **WARNING:** Modification of this equipment may cause excessive wear and will void the warranty. Contact the manufacturer regarding changes or modifications of equipment which could affect reliability or safety.

# 1.0 Safety

## 1.4 Electrical Rating

### 1.4.1 All Reels equipped with cable

1.4.2 Reels equipped with cable are rated based on the installed cable.

SOW-A (90oC) or SOOW-A (105oC)			
Cable: AWG / # of Cond.	Ampacity	Cable: AWG / # of Cond.	Ampacity
16/2	10.0	12/2	20.0
16/3	10.0	12/3	20.0
16/4	8.0	12/4	16.0
16/5	8.0	12/5	16.0
16/6	8.0	12/6	16.0
16/7	7.0	12/7	14.0
16/8	7.0	12/8	14.0
16/10	5.0	10/2	25.0
16/12	5.0	10/3	25.0
14/2	15.0	10/4	20.0
14/3	15.0	10/5	20.0
14/4	12.0	10/6	20.0
14/5	12.0	6/1	75
14/6	12.0	4/1	150
14/7	10.5	2/1	225
14/8	10.5	1/1	300
14/10	7.5	1/0/1	350
14/12	7.5	--	--

## 1.5 Labels & Markings



**LISTED  
REEL  
6 7 N 6**

1.5.1 Every cable reel is marked with a label on the entrance ring which includes the Conductix-Wampfler name and logo, the product catalog number, the individual product serial number.

1.5.2 All 1500 Series PowerReel products are built to UL specifications. Reels that are UL/cUL Listed as Hazardous Location cable reels are certified to meet and comply to requirements for Class 1 - Division 1 - Groups C & D - Zones 0, 1 & 2 and Class 2 - Division 1 - Groups E, F & G as defined in Article 500 of the National Electric Code. Reels Conform to NEMA 4 Standards for applications in wet and dry locations are indicated in the catalog.



1.5.3 The two requirements that follow for UL/cUL listed PowerReel products:

1.5.3.1 Listed cable reels are intended for commercial/industrial use and are provided with permanent mounting means. They must be wired by a qualified electrician. These cable reels are provided with a 6' feeder cord.

1.5.3.2 UL listed type SOW-A or SOOW-A,600V, rated 90°C or 105°C must be used for the supply cable (if flexible cable is used) and for the load end cable (active cable).

1.5.4 The maximum amperage and voltage rating for every cable reel is stamped on the Conductix-Wampfler identification label.

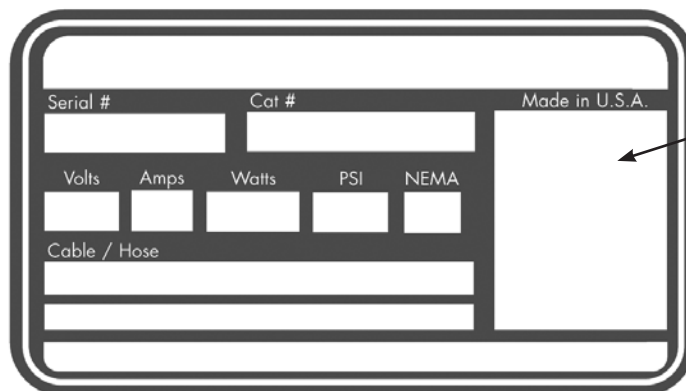

UL label if applicable

## 2.0 Installation

### 2.1 Application Types

#### 2.1.1 Stretch Applications

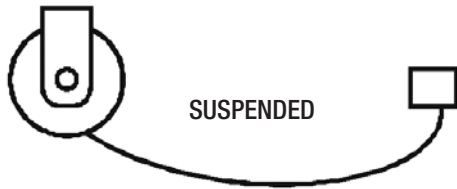

2.1.1.1 The cable is suspended without any intermediate support. Stretch reels generally require a line pull equal to two times the weight of the cable, which allows approximately 10% sag at full extension. On long applications where sag cannot be tolerated, it is sometimes desirable to put supports at intervals of 5 to 10 feet.



#### 2.1.2 Lift Applications

2.1.2.1 The cable is lifted vertically in lift applications. The reel is normally designed to handle only the total weight of the cable. Some lift applications may require a ball stop and ratchet to control the length of cable to be retracted. All 1200 Series reels sold with cable have a ball stop installed on the reel.

#### 2.1.3 Drag Applications

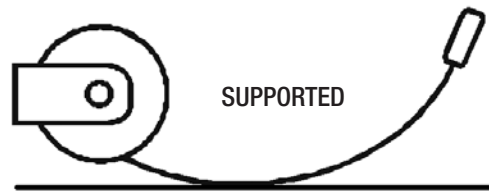

2.1.3.1 The reel is mounted on a stationary object and is required to drag the cable over the surface to the reel. The cable is supported by the ground or some type of cable tray. A ball stop may be required. All 1200 Series reels sold with cable have a ball stop installed on the reel.

#### 2.1.4 Retrieve Applications

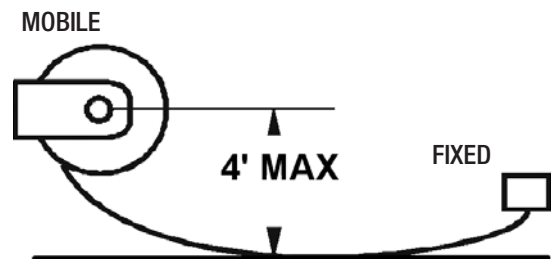

2.1.4.1 The reel is mounted on the moving object and winds up or pays out the cable as the machine approaches or moves away from the fixed end. Retrieve applications can be elevated 4 feet from the cable support surface.

### 2.2 Mounting

#### 2.2.1 Standard Mounting

2.2.1.1 The reel may be mounted by bolting the base to any flat surface which is structurally sound enough to support it and the forces of winding and unwinding the cable.

2.2.1.2 The spool drum must rotate on a level horizontal axis.

2.2.1.3 Position the guide arm so that cable payout is perpendicular to the face of cable roller guide. The total cable deflection should not exceed 15P to either side of the centerline of the spool.

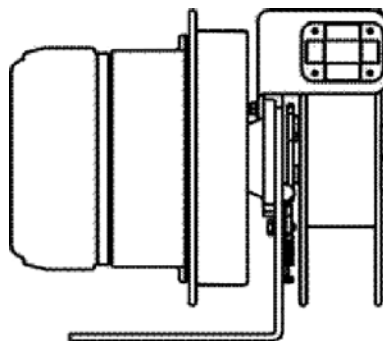

Fig. 2.2 Cable Deflection with Roller

2.2.1.4 If deflection is constant to either side of the reel and operation is impaired, re-mount the reel.

2.2.1.5 If the angle of deflection exceeds  $30^\circ$  a Pivot Base should be used, otherwise excessive cable wear and unreliable operation will result.

2.2.1.6 A safety chain is recommended for all overhead installations. Attach the safety chain using the 0.39 hole provided in the base. (See diagram for Section 2.3.)

## 2.0 Installation

### 2.2.2 Pivot Base Mounting

2.2.2.1 All 1500 Series Cable Reels can be furnished with a spark proof pivot base to allow the reel to rotate and keep the extended cable perpendicular to the application.

2.2.2.2 The XPVB Pivot Base has the ability to rotate up to 340°. This Pivot Base is not suitable for applications requiring continuous rotation.

2.2.2.3 A pivot base is required in carousel or loop-track applications.

2.2.2.4 When a pivot base is used, the reel must be mounted horizontally ("ceiling" or "floor" mounted).

2.2.2.5 The Roller Guide should be mounted so the cable will travel perpendicular to the axis of rotation. This will guard against the cable twisting and ensure effective swivel action from the pivot base.

2.2.2.6 Selection of mounting holes should be such that the spool center is in line with the center point of the pivot base.

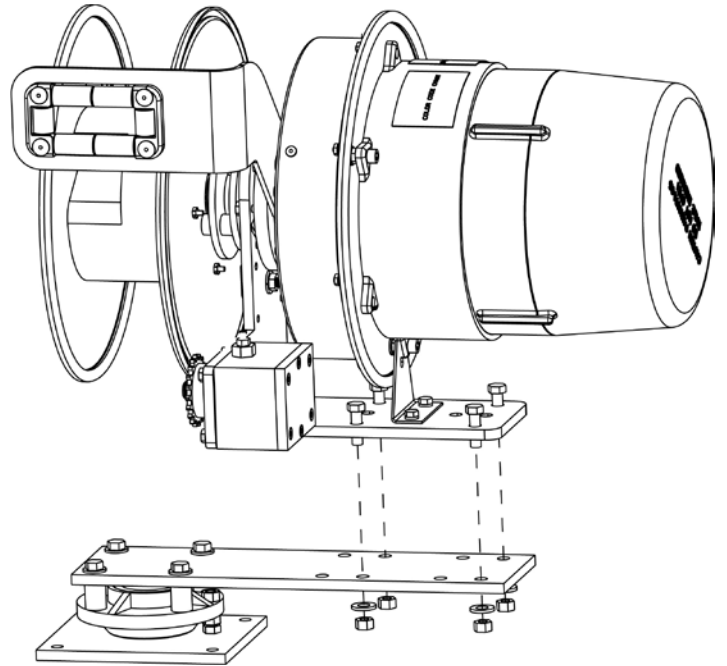

### 2.3 Roller Guide

2.3.1 All 1500 Series units are equipped with a roller guide. The function of the guide is to center the cable on the spool and to help the reel wrap cable more evenly.

2.3.2 The cable should not bear against either end of the spool during winding as this will tend to inhibit level winding of the cable.

2.3.3 The guide should be secured at the best of twelve possible positions so that a minimum change of direction occurs at the guide; otherwise, cable life will be reduced.

2.3.4 The guide is shipped installed on the reel. The guide must be aligned per application and secured prior to making any electrical connections.

2.3.4.1 Mount the roller guide to the reel over the entrance coupling on the frame. Secure using the provided 3/8-16 hex head cap screw, including the spring-type lock washer. Torque this screw to 15 ft-lbs.

**Roller Guide Locations**  
(4 of 12 possible positions shown)

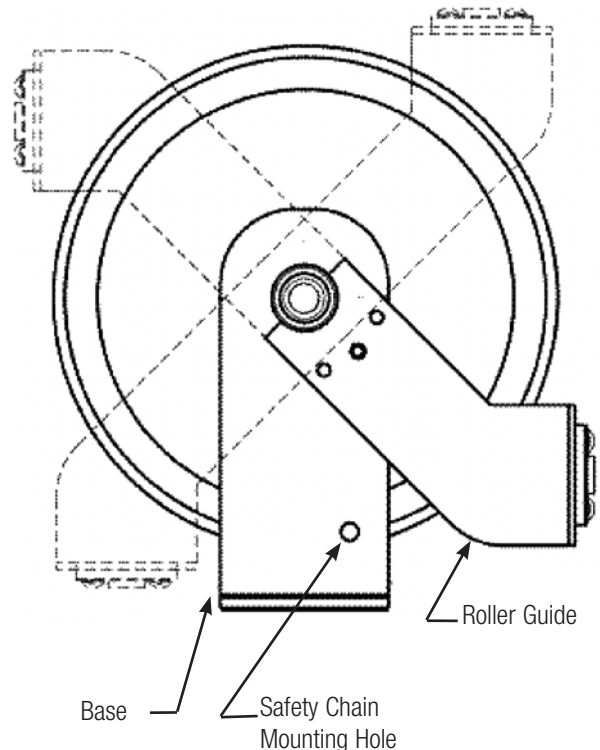

## 2.0 Installation

### 2.4 Ratchet

#### 2.4.1 Ratchet Lock

2.4.1.1 The ratchet lock can be activated or deactivated, depending upon the application.

#### 2.4.2 Operation with Ratchet

2.4.2.1 The ratchet on the 1500 Series Cable Reel is spring loaded. It is designed to function in all acceptable mounting configurations.

#### 2.4.3 Operation without Ratchet

2.4.3.1 Deactivate the ratchet by pivoting the lock-out bar to the lower position. This will remove the ratchet pawl from the path of the ratchet plate. Locate the dimple on the lock out bar in the hole provided.

2.4.3.2 **WARNING:** Do not activate the ratchet abruptly. Sudden activation may cause excessive shock loads to the ratchet pawl which may cause lock-up and/or breakage.

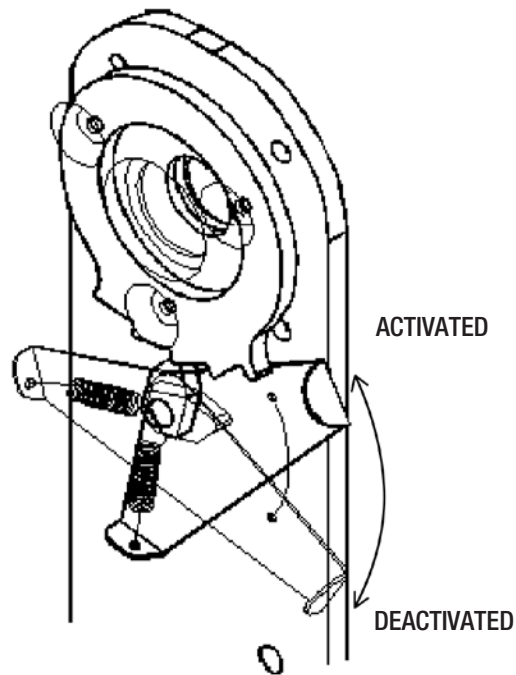

### 2.5 Cable Installation

Cable is factory installed and sealed. Consult factory for changes.

Color Code Chart					
Cond. No.	Base Color	Tracer Color	Cond. No.	Base Color	Tracer Color
1	Green	--	7	White	Black
2	Black	--	8	Red	Black
3	White	--	9	Green	Black
4	Red	--	10	Orange	Black
5	Orange	--	11	Blue	Black
6	Blue	--	12	Black	White

## 2.0 Installation

### 2.6 Spring Tension Adjustment

**2.6.1 WARNING:** Do not allow cable to retract without restraining the retraction speed. Walk the cable back to the reel during the spring tension adjusting process. Always maintain two full cable wraps on drum at maximum cable extension, size cable accordingly.

2.6.2 1500 Series reels come with pre-tension from the factory. Some adjustment may be required to meet specific application requirements.

2.6.3 To assure that the cable will retract properly and operate under the correct tension for intended application; the reel should be tested. Securely mount reel before testing with cable installed on drum and end of spool cable not connected, proceed with steps in section 2.6.4

2.6.4 Pull the cable out the intended travel distance and allow it to rewind. This procedure should be repeated five (5) to ten (10) times in order to set the spring. Walk the cable back to the reel during the spring tension adjusting process.

Rotate Spool While Holding Cable to Test the Spring Tension

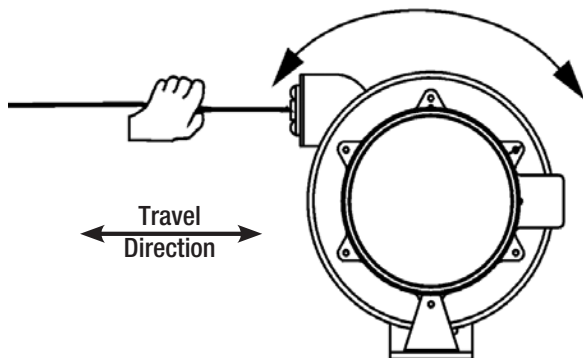

2.6.5 With all the cable wound on the reel, grasp the end of the cable and rotate the drum and cable together in the direction of pay out in order to pre-tension the spring. The number of pre-tension turns is determined by cable size and footage. Usually, four to sixteen turns is sufficient, but additional turns may be used if testing indicates that the cable will not fully retract as desired with just four turns (*See Note 2.6.6*).

Adding Spring Tension

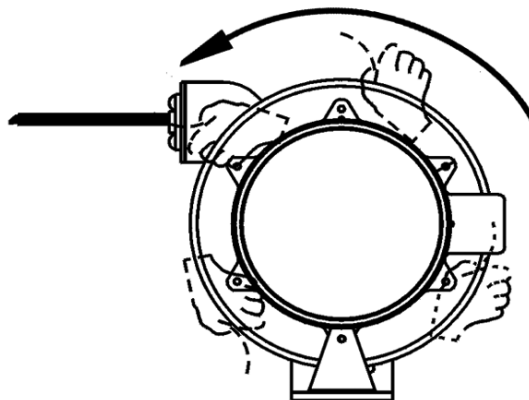

**2.6.6** Feed the end of the cable through the cable guide and pull the cable out the required length. **Note:** Total number of spool revolutions including the pre-tension turns, must not exceed the limits in the following table:

Spring model designation stated in reel description on ID tag invoice and packing slip.					
Models w/#	Available Turns	Set up	Models w/#	Available Turns	Set up
J	23	4	K	29	8
JP	23	4	KP	29	8
JS	46	8	KS	58	16
Consult factory with any questions.					

**2.6.7** Repeat step 2.6.3 to 2.6.5, if necessary, to add tension. To decrease tension, rotate drum and cable counter-clockwise.

Adding Spring Tension

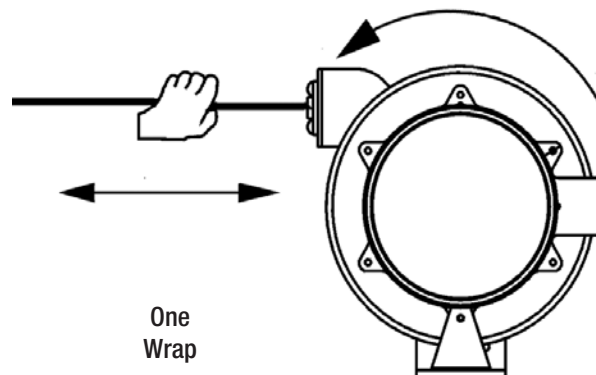

## 2.0 Installation

### 2.7 Power Connections

2.7.1 Provide power source with over-current protection to prevent overheating of the reel and cable.

2.7.2 Reels are supplied with 6 foot feeder cords. Those cords are the same cable as is supplied on the spool. They are factory sealed with explosion proof potting compound and supplied with a watertight strain relief. If a conduit connection is required the strain relief must be removed and conduit connections made.

## 3.0 Operation

3.1 Do not exceed the voltage or amperage rating of the cable. Overheating, fire, damage to equipment or personal injury could result.

3.2 **Do not allow cable to retract without restraining the retraction speed.**

3.3 Operate the reel within the cable size and length and spring tensioning limits for which it was intended.

3.3.1 Keep two wraps of cable on the reel at maximum extension to avoid excessive tension on the cable and to prevent pullout of cable from entrance watertight.

## 4.0 Maintenance

**4.1 WARNING: Be sure all power is off for all maintenance.**

### 4.2 Lubrication

4.2.1 All components requiring lubrication are lubricated for life at the factory. Additional lubrication is not be required.

4.2.2 Do not apply any lubricants or solvent cleaning agents to slip ring, brush or insulator surfaces.

### 4.3 Inspections

4.3.1 Periodically check the reel for any loose or missing fasteners. Tighten or replace as necessary.

4.3.2 The slip ring assembly should be checked periodically as follows:

4.3.2.1 Clean to remove dust and dirt from the slip ring housing area and all slip ring assembly and brush surfaces.

4.3.2.2 Brushes should be centered on slip rings and brush springs should be seated in terminal post grooves. Terminal screw connections should be tight. Check for excessive brush wear. Replace brushes as necessary.

4.3.3 Inspect cable for damage or wear which would make it unsafe to use.

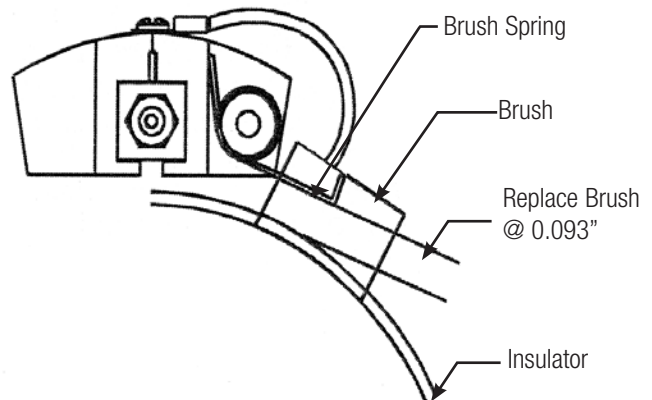

## 4.0 Maintenance

### 4.4 Slip Ring Replacement

4.4.1 **NOTE:** The slip ring assembly should be replaced, not rebuilt, if it becomes damaged.

4.4.2 Due to factory sealing of explosion proof unit, slip ring replacement should only be done by the factory.

### 4.5 Cable Replacement

4.5.1 Cable replacement should only be attempted by the factory. (Possible complete reel replacement)

### 4.6 Spring Motor Replacement

4.6.1 **CAUTION:** Do not open the spring motor or personal injury may result.

4.6.2 Due to spool cable being sealed in the shaft, spring motors can only be factory rebuilt, and replaced.

## 5.0 Troubleshooting

PROBLEM	POSSIBLE CAUSE	SOLUTION
Reel will not retract cable but has some tension.	<ol style="list-style-type: none"> <li>1) Improper pretension.</li> <li>2) Incorrect reel for application (lift vs. stretch).</li> <li>3) Cable guide adjustment</li> </ol>	<ol style="list-style-type: none"> <li>1) See Sec 2.6 Spring Tension Adjustment</li> <li>2) Quantify application vs. reel selection.</li> <li>3) Check guide alignment (see Sec 2.2 and 2.3)</li> </ol>
Reel does not have any spring tension.	<ol style="list-style-type: none"> <li>1) Broken spring. "Quantify application to prevent recurrence.</li> </ol>	<ol style="list-style-type: none"> <li>1) Factory rebuild (See Sec 4.6)</li> </ol>
Ratchet will not activate.	<ol style="list-style-type: none"> <li>1) Broken ratchet pawl spring.</li> <li>2) Lock-out option arm deactivated.</li> </ol>	<ol style="list-style-type: none"> <li>1) Replace ratchet pawl spring.</li> <li>2) Activate lock-out arm (See Sec 2.4)</li> </ol>
Ratchet will not deactivate	<ol style="list-style-type: none"> <li>1) Over-extension of reel.</li> </ol>	<ol style="list-style-type: none"> <li>1) Manually rotate reel spool to deactivate ratchet. Do not over-extend. (Guide adjustment may prevent lock-up when over-extended.)</li> </ol>
Cable wraps improperly (uneven wrapping, wraps above or jumps flange).	<ol style="list-style-type: none"> <li>1) Reel mounting no level.</li> <li>2) Cable retraction rate too high.</li> <li>3) Cable guide out of adjustment.</li> </ol>	<ol style="list-style-type: none"> <li>1) Mount reel on level surface</li> <li>2) Maintain steady retraction rate.</li> <li>3) Properly adjust cable guide (see Sec. 2.2 and 2.3).</li> </ol>
Cable twisting and knotting.	<ol style="list-style-type: none"> <li>1) Improperly installed cable</li> <li>2) Cable rubbing on or bending around fixed object.</li> <li>3) Excessive spring tension</li> <li>4) Inadequate anchoring of cable.</li> </ol>	<ol style="list-style-type: none"> <li>1) See Sec 2.5 Cable Installation.</li> <li>2) Check roller guide for function and cable payout path (see Sec 2.3).</li> <li>3) Quantify application vs. reel selection. Also check pretension.</li> <li>4) Adjust anchoring method i.e. and strain relief</li> </ol>
Open or intermittent circuit.	<ol style="list-style-type: none"> <li>1) Inadequate connection.</li> <li>2) Loss of brush contact to slip ring.</li> <li>3) Cable defective.</li> </ol>	<ol style="list-style-type: none"> <li>1) Check all termination points.</li> <li>2) Check brush wear, spring tension &amp; alignment.</li> <li>3) Perform continuity check on cable termination points.</li> </ol>
Circuit trips and/or Pitted burned rings or brushes.	<ol style="list-style-type: none"> <li>1) Inadequate amp rating of reel selection.</li> </ol>	<ol style="list-style-type: none"> <li>1) Quantify application requirements vs. reel and cable rating (see Sec. 1.5)</li> </ol>
Circuit arcing	<ol style="list-style-type: none"> <li>1) Amp or voltage above rating of reel.</li> <li>2) Excessive carbon dust accumulation</li> <li>3) Loss of brush to ring contact.</li> </ol>	<ol style="list-style-type: none"> <li>1) Quantify application requirements vs. reel and cable rating (see Sec 1.5).</li> <li>2) Clean dust from inside slip ring.</li> <li>3) Replace brush and/or brush spring.</li> </ol>

## 6.0 Replacement Parts

### SLIP RINGS

Part No.	Volts	Amps	Conductors
RA-D03-PR	600	35	3
RA-D04-PR	600	35	4
RA-C05-PR	250	35	5
RA-C06-PR	250	35	6
RA-C07-PR	250	35	7
RA-C08-PR	250	35	8
RA-C010-PR	250	35	10
RA-C012-PR	250	35	12

### COMPONENTS

Part No.	Description
X967A	Slip Ring Cover (8.5-M)
42824	Guide Arm for 3.0" wide drum
42825	Guide Arm for 4.5" wide drum
42826	Guide Arm for 6.0" wide drum
42714	Outer Flange
PR91	Ratchet pawl & pin

## Notes

## Notes

## Notes

[www.conductix.com](http://www.conductix.com)

**Conductix-Wampfler**

10102 F Street  
Omaha, NE 68127  
USA

Customer Support  
Phone: 800 521 4888  
Fax: 800 780 8329

Phone: 402 339 9300  
Fax: 402 339 9627

[info.us@conductix.com](mailto:info.us@conductix.com)  
[www.conductix.com](http://www.conductix.com)

