

Slip Rings V Series



CONDUCTIX INCORPORATED

The technical data and images which appear in this manual are for informational purposes only. **NO WARRANTIES, EXPRESS OR IMPLIED, INCLUDING WARRANTIES OF MERCHANTABILITY OR FITNESS FOR A PARTICULAR PURPOSE, ARE CREATED BY THE DESCRIPTIONS AND DEPICTIONS OF THE PRODUCTS SHOWN IN THIS MANUAL.** Conductix makes no warranty (and assumes no liability) as to function of equipment or operation of systems built according to customer design or of the ability of any of its products to interface, operate or function with any portions of customer systems not provided by Conductix.

Seller agrees to repair or exchange the goods sold hereunder necessitated by reason of defective workmanship and material discovered and reported to Seller within one year after shipment of such goods to Buyer.

Except where the nature of the defect is such that it is appropriate, in Seller's judgment, to effect repairs on site, Seller's obligation hereunder to remedy defects shall be limited to repairing or replacing (at Seller's option) FOB point of original shipment by Seller, any part returned to Seller at the risk and cost of Buyer. Defective parts replaced by Seller shall become the property of Seller.

Seller shall only be obligated to make such repair or replacement if the goods have been used by Buyer only in service recommended by Seller and altered only as authorized by Seller. Seller is not responsible for defects which arise from improper installation, neglect, or improper use or from normal wear and tear.

Additionally, Seller's obligation shall be limited by the manufacturer's warranty (and is not further warranted by Seller) for all parts procured from others according to published data, specifications or performance information not designed by or for Seller.

Seller further agrees to replace or at Seller's option to provide a refund of the sales price of any goods that do not conform to applicable specifications or which differ from that agreed to be supplied which non-conformity is discovered and forthwith reported to Seller within thirty (30) days after shipment to the Buyer. Seller's obligation to replace or refund the purchase price for non-conforming goods shall arise once Buyer returns such goods FOB point of original shipment by Seller at the risk and cost of Buyer. Goods replaced by Seller shall become the property of Seller.

There is no guarantee or warranty as to anything made or sold by Seller, or any services performed, except as to title and freedom from encumbrances and, except as herein expressly stated and particularly, and without limiting the foregoing, **there is no guarantee or warranty, express or implied, of merchantability or of fitness for any particular purpose or against claim of infringement or the like.**

Seller makes no warranty (and assumes no liability) as to function of equipment or operation of systems built to Buyer's design or of the ability of any goods to interface, operate or function with any portions of Buyer's system not provided by Seller.

Seller's liability on any claim, whether in contract, tort (including negligence), or otherwise, for any loss or damage arising out of, connected with, or resulting from the manufacture, sale, delivery, resale, repair, replacement or use of any products or services shall in no case exceed the price paid for the product or services or any part thereof which give rise to the claim. In no event shall Seller be liable for consequential, special, incidental or other damages, nor shall Seller be liable in respect of personal injury or damage to property not the subject matter hereof unless attributable to gross misconduct of Seller, which shall mean an act or omission by Seller demonstrating reckless disregard of the foreseeable consequences thereof.

Seller is not responsible for incorrect choice of models or where products are used in excess of their rated and recommended capacities and design functions or under abnormal conditions. Seller assumes no liability for loss of time, damage or injuries to property or persons resulting from the use of Seller's products. Buyer shall hold Seller harmless from all liability, claims, suits and expenses in connection with loss or damage resulting from operation of products or utilization of services, respectively, of Seller and shall defend any suit or action which might arise there from in Buyer's name - provided that Seller shall have the right to elect to defend any such suit or action for the account of Buyer. The foregoing shall be the exclusive remedies of the Buyer and all persons and entitles claiming through the Buyer.

1.0 SAFETY

- 1.1 Electrical Warnings
- 1.2 Operational Warnings
- 1.3 Maintenance Warnings
- 1.4 Specifications & Listings
- 1.5 Temperature & Ampere / Voltage Ratings
- 1.6 Markings

2.0 INSTALLATION

- 2.1 Mounting
 - 2.1.1 Mounting the slip ring to a shaft
 - 2.1.2 Driving the slip ring
- 2.2 Wiring & Connections
- 2.3 Handling

3.0 MAINTENANCE

- 3.1 Lubrication
- 3.2 Inspections
 - 3.2.3 Brushes
 - 3.2.4 Brush Springs
 - 3.2.5 Brush Fit Inspection
 - 3.2.6 Brush Spring Installation
 - 3.2.7 Ring Inspection
 - 3.2.8 Electrical Connections
 - 3.2.9 Brush Rigging
 - 3.2.10 Enclosure Inspection

4.0 STORAGE

5.0 SERIAL NUMBER RECORD

6.0 TROUBLESHOOTING

7.0 REPLACEMENT PARTS

1.0 SAFETY

1.0.1 **ATTENTION:** Read this entire booklet prior to attempting any installation and/or maintenance.

1.1 Electrical Warnings

1.1.1 Install and ground the slip ring and the entire unit in accordance with the National Electric Code and local codes and/or ordinances.

1.1.2 **DANGER:** Hazard of electrical shock or burn. Always disconnect the power from the collector ring before attempting to perform any service function. Follow lock-out/tag-out procedures as outlined in OSHA section 1910.147 where appropriate.

1.1.3 Do not use this slip ring with electrical loads greater than the rated current and voltage.

1.1.4 Information regarding the current and voltage rating of each slip ring is recorded on a tag permanently fastened to the ring assembly.

1.2 Operational Warnings

1.2.1 Slip rings must be enclosed and protected from any contact by personnel. Means for the provision of this protection is the responsibility of the user. Various enclosure styles are available from Conductix.

1.2.2 **WARNING:** Modification of this equipment may cause excessive wear or failure and will void the warranty.

1.2.3 **WARNING:** Modification may cause safety and fire hazards. Contact the manufacturer regarding any modifications which could affect safety or reliability.

1.3 Maintenance Warnings

1.3.1 Exercise care while servicing, adjusting, and operating the slip ring.

1.3.2 Periodically check all fasteners and hardware to assure tightness.

1.3.3 Install all mounting fasteners and hardware to maintain tightness under vibration.

1.3.4 If you have any questions about the use or the installation of V-Series Slip Rings that are not answered in this document contact the factory for assistance.

In the U.S. call: 1-800-521-4888

In Canada call: 1-800-667-2487

1.4 Specifications & Listings

1.4.1 V-Series Slip Ring products are built to N.E.C. guidelines and complies to U.L. 508 specifications, and are not generally certified or listed by any independent certifying or regulatory body.

1.4.2 The following specifications apply to all V-Series Slip Rings:

1.4.2.1 V-Series Slip Rings are intended for industrial use and require a permanent mounting means.

1.4.2.2 Maximum RPM is 125.

1.5 Temperature & Ampere/Voltage Ratings

1.5.1 V-Series Slip Rings withstand a maximum ambient temperature of 220° F.

1.5.2 The actual ampacity may be affected by the type and size of the core lead wire (refer to NEC Table 310-16,17,18, 19 and applicable notes).

1.6 Markings

1.6.1 Every slip ring is marked with a label on the outboard bearing (or enclosure) which includes the Conductix name and logo, the product catalog number and the individual product serial number.

1.6.2 The marking on slip rings includes the maximum rated amperage and voltage.

2.0 INSTALLATION

2.1 Handling

2.1.1 Carry the assembly by the enclosure, the core attachment (example: shaft), or by the core for either vertical or horizontal support.

NOTE: NEVER SUPPORT OR CARRY UNIT BY CORE LEADS.

2.2 Application Types

2.2.1 Slip ring assemblies can be purchased with or without an enclosure.

Such enclosures are:

- Wrap around shroud
- Revolving enclosure with shaft flange
- Stationary enclosure with rotating elbow

Note: User must enclose the slip ring appropriately to meet safety codes and to protect the ring.

2.3 Mounting

2.3.1 Warning: During installation of the slip ring, proper air gap must be maintained between conductive items, and all terminal connections. Refer to U.L. 508 standards.

2.3.1.1 Slip ring assemblies are to be mounted on the center axis of the application.

2.3.1.2 Unenclosed slip ring assemblies are made up of two basic components, the brush carriage and the core. The brush carriage is made up of the brush posts, brushes, brush holders, and outboard bearings. The core is made up of the rings, insulators, drive collar, ball or friction type bearings, and leads extending from the end on the outside of the through bore.

2.3.1.3 The slip ring assembly is a through bore design and is to be mounted onto a shaft using the set screws in the drive collar.

2.3.1.4 The slip ring assembly can be operated with either the brush carriage or the slip ring core rotating and the other stationary. One of these elements must be stationary in relationship to the other for proper operation. This is called "driving" the ring.

Note: The term "driving" is referring to holding stationary or rotating either the brush carriage or the core.

2.3.1.5 The brush carriage on a standard slip ring assembly has drive holes in the outboard bearings (see figure 1).

2.3.1.6 Unenclosed slip ring assemblies and assemblies with wrap around cover(s) can be installed with either the brush carriage or core rotating. One of these items is to be held stationary in relationship to the other for proper operation.

2.3.1.7 On enclosed slip ring assemblies, the brush carriage is driven by the enclosure and the core is driven by the shaft. One of these items must be held stationary in relationship to the other for proper operation.

2.3.1.8 Due to some types of applications and/or the size of the slip ring assembly, the brush carriage maybe required to be driven from both ends. Driving the brush carriages from both ends will prevent the brush carriage from racking or twisting. Special slip ring assemblies may have a special drive arm type device(s) for driving the brush carriage.

2.3.1.9 When driving and to avoid putting strain on the slip ring assembly, the brush carriage or core **MUST be driven by a "loose link" or "floating" type drive connection or mechanism.** Meaning that there is to be "play" between one of the slip ring driven items, which is either the brush carriage or core, and the device that is driving it. There should be "play" between this slip ring and the item that is driving it.

2.3.1.10 **Note:** The loose link or floating type drive connection or mechanism is required due to run-out and or deflection that may occur during operation. If this is not followed, premature wear or failure of the slip ring assembly will occur.

2.3.2 Installation

2.3.2.1 For an unenclosed slip ring, locate a torque arm, pin, bolt, or suitable member to the available holes in the outboard bearing on the drive collar end. To avoid putting strain on the assembly, the drive connection must be a "loose link" or "floating" type connection. There should be "play" between the slip ring and the item that is driving it

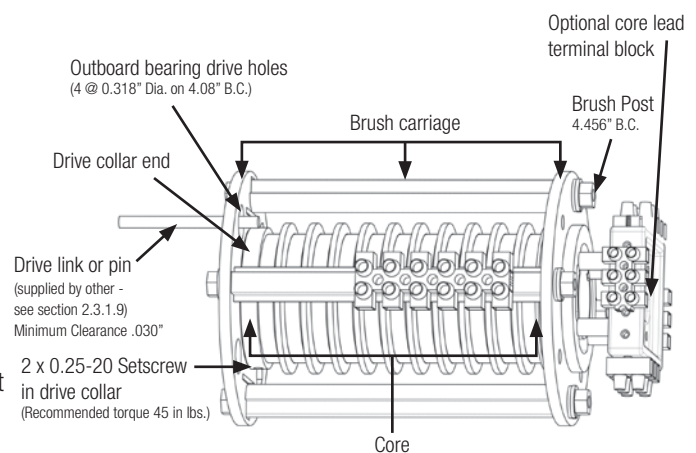

Figure 1

Warning: During installation of the slip ring, proper air gap must be maintained between conductive items, and all terminal connections. Refer to U.L. 508 standards.

2.0 INSTALLATION

2.3.2.2 For an enclosed slip ring assembly that has a factory installed mounting shaft, the assembly is to be driven by either the enclosure or at the end of the supplied shaft. The slip ring assembly is to be driven by a torque arm, pipe or other suitable member. Again, to avoid putting strain on the assembly, the drive connection must be a “loose link” or “floating” type connection. There should be “play” between the slip ring and the item that is driving it.

2.3.2.3 For an enclosed slip ring assembly supplied without a shaft and mounting flange, the assembly is to be mounted onto a shaft as described in the mounting section 2.3. On a flat based style enclosed assembly with a bolted top hat style cover, access to the two 0.25-20 drive collar set screws can be gained by removing the bolted cover from the flat base of the assembly. On the two piece style enclosure without a flat base, access to the two 0.25-20 drive collar set screws can be gained by removing the plug on the side of the bolted base cover of the assembly. The factory supplied thrust washer/seal kit are to be installed onto the mounting shaft before installation (see figure 2). The seal is to be installed first with the outer lip facing the thrust washer and the thrust washer is to be installed second. After the shaft is installed, the thrust washer is to be placed up against the outside of the enclosure cover and the seal up against the washer.

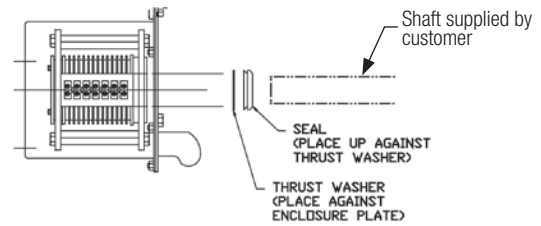

Figure 2

2.3.2.3 **Note:** If voltage exceeds 250V, the shaft should not extend past the drive collar into the slip ring core unless special insulating modifications are made at the factory. Contact factory for details.

2.3.2.4 It is not recommended to drive the unit from the core lead end. (See Figure 1) Also, do not drive the core or the brush carriage by the wire leads.

2.3.2.5 The assembly should turn easily when the center core is rotated. Some friction is expected inside the brush assembly, but it should be evenly distributed with no tight spots.

2.2 Wiring & Connections

2.2.1 Perform all wiring according to National Electrical Code guidelines and any applicable local codes.

2.2.2 Make electrical connections to the 15, 35, and 75 amp brushes through the barrel connectors in the provided terminal strips. See Figure 3 illustration.

2.2.3 The barrel connectors in the terminal blocks require 5/16 inch of stripped insulation.

2.2.4 The optional core lead terminal block provides connections to the rings. Use the appropriate crimp connectors if the terminal block is not supplied. See Section 2 (Figure 1) for cable lead terminal block illustration.

2.2.5 Screws used in the electrical connections must be tightened to achieve the designed electrical rating.

2.2.6 Make connections with stranded wire whenever possible.

2.2.7 Brush lead connections are numbered to the corresponding core lead connections. Wire connections accordingly.

2.2.8 For wiring the optional heater with thermostat: from the power source, connect one lead to the power and the other lead to the neutral or negative (power in and power out). Note: If the thermostat is supplied separate from the heater, the thermostat is to be wired in series with the power lead.

2.3 Handling

2.3.1 Carry the assembly by the enclosure, the core attachment (example: shaft), or by the core for either vertical or horizontal support.

2.3.2 **NOTE: NEVER SUPPORT OR CARRY UNIT BY CORE LEADS.**

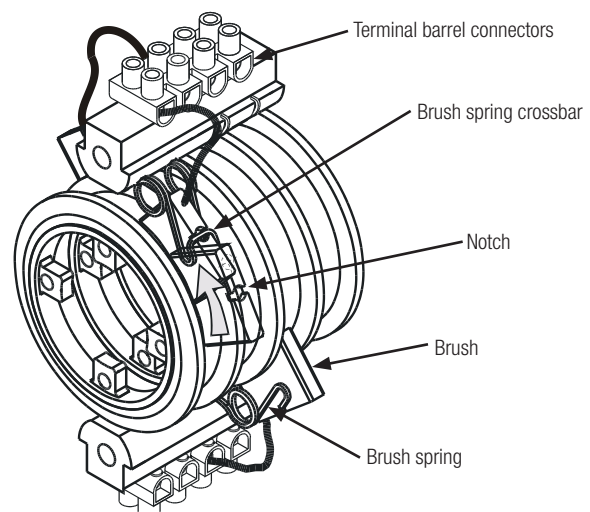

Figure 3

3.0 MAINTENANCE

3.1 Lubrication

3.1.1 All bearings are lubricated for life of the assembly at the factory.

3.2 Inspections

3.2.1 Before performing inspections and maintenance procedures, insure all power is disconnected and all safety procedures (lock-out / tag-out) are followed.

3.2.2 Make the first inspection shortly after installation and/or before operation to insure all electrical connections are tight and all mechanical items are properly adjusted. Make continuing preventive maintenance inspections on a regular basis after every 200-400 hours of operation under normal conditions. The need for periodic preventive maintenance inspections can be tailored and/or varied depending on the application requirements.

3.2.3 Brushes

3.2.3.1 Inspect for wear. If the distance from the top of the insulator to the lower part of the brush spring is 0.093" or less, replace the brush.

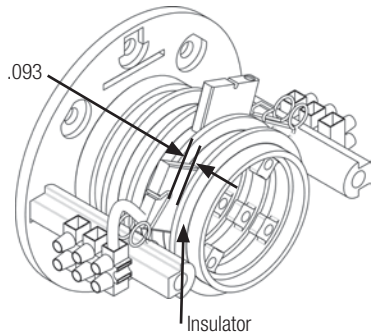

3.2.3.2 Inspect brush contact surface by removing the brush. Remove surface dirt, oxidation, pitting, or other contaminants with a brass or poly brush or cleaner kit (see section 7.0.)

3.2.3.3 Replace springs when brushes require replacement to assure proper spring pressure.

3.2.4 Brush Springs

3.2.4.1 Inspect and test brush springs to assure uniform brush pressure. Replace if brush springs fall below recommended pressure. The spring tension, as measured at the top center of the brush, should be as follows:

15 amp	1.5 lb. min
35 amp	2.0 lb. min

3.2.5 Brush Fit Inspection

3.2.5.1 Brushes must run at $90^\circ \pm 3^\circ$ square on the rings. If brush is not square, adjust to vertical by moving the coil of the spring.

3.2.5.2 Brushes need not run on the center of the rings, but there should be no forceful friction against the insulators.

3.2.5.3 Spring hooks must seat securely on brushposts.

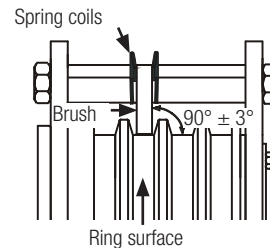

3.2.6 Brush Spring Installation

3.2.6.1 Brush installation consists of attaching the springs to the brush post and centering them over the circuit, locating the brushes, and connecting the wires.

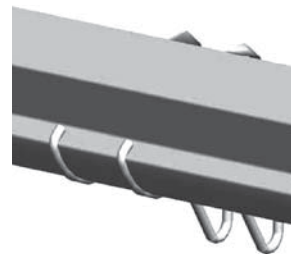

3.2.6.2 Snap both rear legs of the spring on the brush posts (see Sec. 3.2.5 illustration) and center the spring. Lift the spring at the crossbar and start the brush under it. Position the brush so the notch fits under the brush spring crossbar.

3.2.6.3 Remove brushes by lifting the spring crossbar and rotating the brush free of the spring.

3.2.6.4 Brush lead terminal barrel connectors require 5/16 of stripped wire. Insert the stripped lead into the barrel connector and tighten the screw.

3.2.6.5 CAUTION: Do not lift the spring crossbar more than 1/8" inch above the top of the brush. Keep the brush flat on the ring at all times. Over-extension of the brush spring will cause a reduction in spring pressure.

3.0 MAINTENANCE

3.2.7 Ring Inspection

3.2.7.1 Do not apply any lubricants, solvents, or spray cleaning agents to any part of the slip ring. Use only clean, dry air to clean the slip ring assembly.

3.2.7.2 Inspect the ring surface for dirt, oxidation, or other contaminants. A properly operating ring will have a film that appears burnished in color with a darker surrounding color where the brushes track. If the ring requires cleaning, order Slip Ring Polishing Kit #41286.

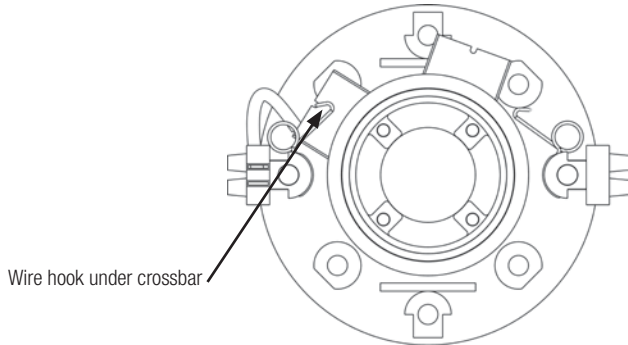

CAUTION: Do not lift more than 1/8" or spring pressure will be affected

3.2.8 Electrical Connections

3.2.8.1 Inspect all electrical connections for corrosion and tightness. Clean corroded parts with a wire brush and/or muriatic acid. Loose and/or corroded terminations will cause a concentration of excessive heat.

3.2.9 Brush Rigging

3.2.9.1 Brush posts are supported between two out board bearings. The brush posts extend to the outboard bearings and are secured by a notch in the outboard bearing. The notch prevents rotation of the brush post.

3.2.9.2 Spacing between the outboard bearings is critical to assure the free rotation of the brush rigging. The brush posts are cut to an exact length in order to provide the proper spacing. Locate the outboard bearings against the insulator and have a 0.20" clearance without deformation of the material.

CAUTION: Do not over-tighten the outboard brush post jam nuts. Make a final check to assure there is no binding of the outboard brush rigging or binding of brushes with insulator barriers.

3.2.10 Enclosure Inspection

3.2.10.1 Moisture is a major cause of slip ring deterioration. Water will corrode parts and breakdown insulation. Dust and dirt present within the enclosure will effect the proper operation of the assembly. Most dusts cause excessive brush and slip ring wear, and conductive dust, if allowed to accumulate, will form a path for short circuiting.

3.2.10.2 A properly designed NEMA 4 enclosure will be dust tight and water tight. However, NEMA 4 enclosures do not eliminate internal condensation. Condensation can be eliminated with the addition of a breather, drain, and a thermostatically controlled heater.

3.2.10.3 Periodically perform an inspection by removing the enclosure and checking for condensation, water and dust collection. If contaminants are found, wipe the enclosure and the assembly with a lint free cloth. If the problem persists, take steps to remedy the leakage or condensation problem.

3.2.11 Cleaning

3.2.11.1 In addition to using the slip ring polishing kit #41286 when cleaning the slip ring assembly, use only clean dry low pressure air or a vacuum cleaner to remove the contaminants from the rings. Do not use any solvents, aerosol sprays, or liquid cleaners on the slip ring assembly.

4.0 STORAGE

4.1 When storing the slip ring, keep it at room temperature in a clean, dry, protective place. Place self-contained or bagged absorbent material in the collector ring enclosure during extended periods of storage. Remove absorbent material before putting collector ring into operation.

5.0 SERIAL NUMBER RECORD

5.1 Make the following information available when ordering replacement parts or discussing the slip ring with the factory by recording the information in the spaces provided here. This information is located on your packing slip, factory invoice, and serial number tag.

Catalog No. Slip Ring: _____

Serial No.: _____

Date of Purchase: _____

6.0 TROUBLESHOOTING

6.1 Some possible problems are addressed in the table here, otherwise, contact the factory at the numbers provided on the back page.

Problem	What to check
Intermittent Signal or Loss of Signal	Verify brush wear per Section 3.2.3
	Check spring pressure per section 3.2.4
	Check contact surface for cleanness (Ring Polishing Kit available. See Replacement Parts below.)
	Visually check for spring fit and function. Adjust or replace as necessary.
	Check core wiring for short circuit.

7.0 REPLACEMENT PARTS

CATALOG NO. _____ SERIAL NO. _____

NOTE: Catalog number is required when ordering spare parts.

QTY	PART NO.	DESCRIPTION
	30088	35 amp Brush
	30088A	35 amp Brush 5.5" shunt lead (Copper Graphite)
	30066A	15 amp Brush (Copper Graphite)
	30066A-LS	15 amp Brush 6.0" shunt lead (Copper Graphite)
	30067A	15 amp Brush (Silver Graphite)
	30067A-LS	15 amp Brush 6.0" shunt lead (Silver Graphite)
	41019	35 amp Spring Holder
	41346	15 amp Spring Holder
	41286	Ring Polishing Kit

NOTE: 75 amp brushes equals or requires a qty of one each of a 30088 and 30088A - Brushes

75 amp springs equals or requires a qty of two of part # 41019 - Spring Holders

NOTES

NOTES

www.conductix.com

Conductix-Wampfler

10102 F Street
Omaha, NE 68127
USA

Customer Support
Phone: 800 521 4888
Fax: 800 780 8329

Phone: 402 339 9300
Fax: 402 339 9627

info.us@conductix.com
www.conductix.com

