

Slip Rings R Series

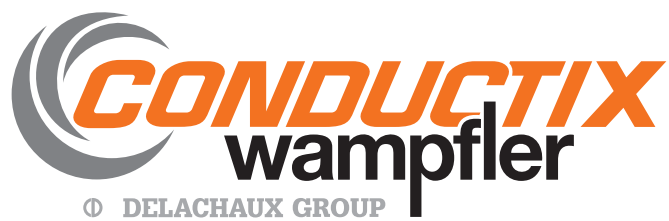
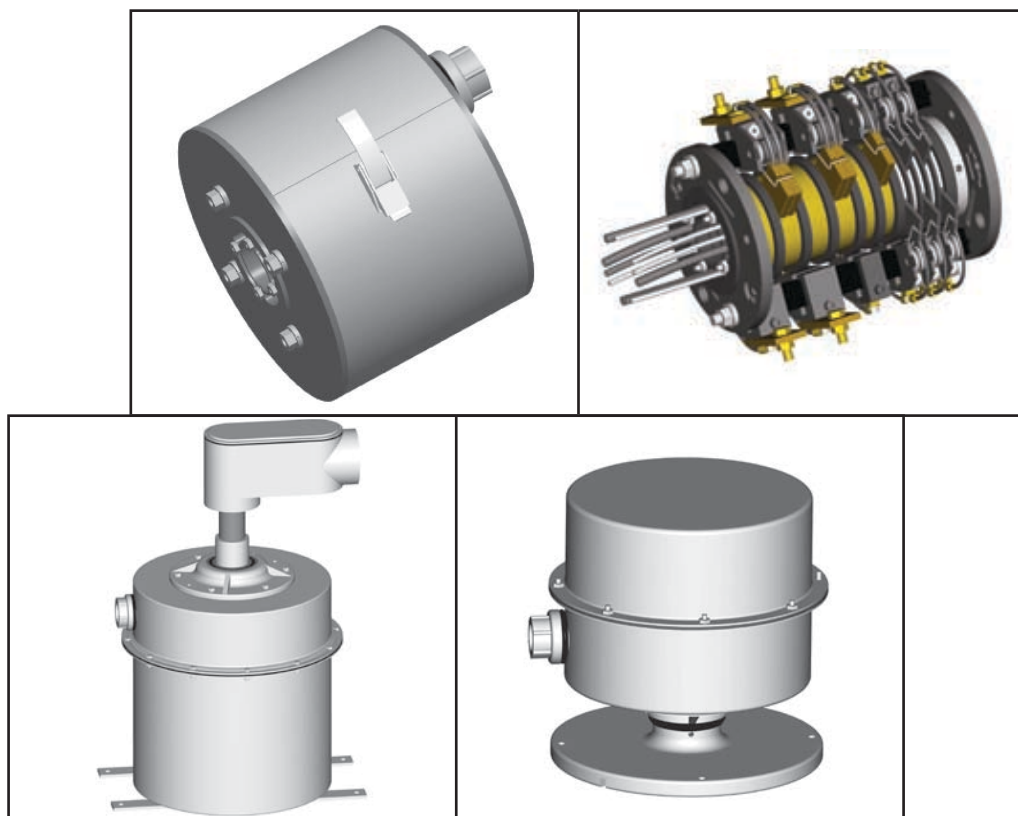

CONDUCTIX INCORPORATED

The technical data and images which appear in this manual are for informational purposes only. **NO WARRANTIES, EXPRESS OR IMPLIED, INCLUDING WARRANTIES OF MERCHANTABILITY OR FITNESS FOR A PARTICULAR PURPOSE, ARE CREATED BY THE DESCRIPTIONS AND DEPICTIONS OF THE PRODUCTS SHOWN IN THIS MANUAL.** Conductix makes no warranty (and assumes no liability) as to function of equipment or operation of systems built according to customer design or of the ability of any of its products to interface, operate or function with any portions of customer systems not provided by Conductix.

Seller agrees to repair or exchange the goods sold hereunder necessitated by reason of defective workmanship and material discovered and reported to Seller within one year after shipment of such goods to Buyer.

Except where the nature of the defect is such that it is appropriate, in Seller's judgment, to effect repairs on site, Seller's obligation hereunder to remedy defects shall be limited to repairing or replacing (at Seller's option) FOB point of original shipment by Seller, any part returned to Seller at the risk and cost of Buyer. Defective parts replaced by Seller shall become the property of Seller.

Seller shall only be obligated to make such repair or replacement if the goods have been used by Buyer only in service recommended by Seller and altered only as authorized by Seller. Seller is not responsible for defects which arise from improper installation, neglect, or improper use or from normal wear and tear.

Additionally, Seller's obligation shall be limited by the manufacturer's warranty (and is not further warranted by Seller) for all parts procured from others according to published data, specifications or performance information not designed by or for Seller.

Seller further agrees to replace or at Seller's option to provide a refund of the sales price of any goods that do not conform to applicable specifications or which differ from that agreed to be supplied which non-conformity is discovered and forthwith reported to Seller within thirty (30) days after shipment to the Buyer. Seller's obligation to replace or refund the purchase price for non-conforming goods shall arise once Buyer returns such goods FOB point of original shipment by Seller at the risk and cost of Buyer. Goods replaced by Seller shall become the property of Seller.

There is no guarantee or warranty as to anything made or sold by Seller, or any services performed, except as to title and freedom from encumbrances and, except as herein expressly stated and particularly, and without limiting the foregoing, **there is no guarantee or warranty, express or implied, of merchantability or of fitness for any particular purpose or against claim of infringement or the like.**

Seller makes no warranty (and assumes no liability) as to function of equipment or operation of systems built to Buyer's design or of the ability of any goods to interface, operate or function with any portions of Buyer's system not provided by Seller.

Seller's liability on any claim, whether in contract, tort (including negligence), or otherwise, for any loss or damage arising out of, connected with, or resulting from the manufacture, sale, delivery, resale, repair, replacement or use of any products or services shall in no case exceed the price paid for the product or services or any part thereof which give rise to the claim. In no event shall Seller be liable for consequential, special, incidental or other damages, nor shall Seller be liable in respect of personal injury or damage to property not the subject matter hereof unless attributable to gross misconduct of Seller, which shall mean an act or omission by Seller demonstrating reckless disregard of the foreseeable consequences thereof.

Seller is not responsible for incorrect choice of models or where products are used in excess of their rated and recommended capacities and design functions or under abnormal conditions. Seller assumes no liability for loss of time, damage or injuries to property or persons resulting from the use of Seller's products. Buyer shall hold Seller harmless from all liability, claims, suits and expenses in connection with loss or damage resulting from operation of products or utilization of services, respectively, of Seller and shall defend any suit or action which might arise there from in Buyer's name - provided that Seller shall have the right to elect to defend any such suit or action for the account of Buyer. The foregoing shall be the exclusive remedies of the Buyer and all persons and entities claiming through the Buyer.

1.0 SAFETY

- 1.1 Electrical Warnings
- 1.2 Operational Warnings
- 1.3 Maintenance Warnings
- 1.4 Specifications & Listings
- 1.5 Temperature & Ampere / Voltage Ratings
- 1.6 Markings

2.0 INSTALLATION

- 2.1 Handling
- 2.2 Application Types
- 2.3 Mounting
 - 2.3.1 General instructions for all assemblies
 - 2.3.2 Un-enclosed assemblies and assemblies with wrap around covers
 - 2.3.3 Revolving Covers (RU)
 - 2.3.4 Swivel Enclosure (SU) (RAQ/RBQ)
 - 2.3.5 Explosion Proof Enclosures (XRU, XSU, and XSU with Optional Air Pass)
- 2.4 Wiring and Connections

3.0 MAINTENANCE

- 3.1 Lubrication
- 3.2 Inspections
- 3.3 Brush Holders
- 3.4 Brushes
- 3.5 Brush Fit Inspection
- 3.6 Brush Springs
- 3.7 Rings
- 3.8 Electrical Connections
- 3.9 Brush Rigging
- 3.10 Enclosure Inspection

4.0 STORAGE

5.0 SERIAL NUMBER RECORD

6.0 TROUBLESHOOTING

7.0 REPLACEMENT PARTS

1.0 SAFETY

1.0.1 ATTENTION: Read this entire booklet prior to attempting any installation and / or maintenance.

1.1 Electrical Warnings

1.1.1 Install and ground the slip ring and the entire unit in accordance with the National Electric Code and local codes and/or ordinances.

1.1.2 **DANGER:** Hazard of electrical shock or burn. Always disconnect the power from the collector ring before attempting to perform any service function. Follow lock out/tag-out procedures as outlined in OSHA section 1910.147 where appropriate.

1.1.3 Do not use this slip ring with electrical loads greater than the rated current and voltage. (See page 8).

1.1.4 Information regarding the current and voltage rating of each slip ring is recorded on a tag permanently fastened to the ring assembly.

1.2 Operational Warnings

1.2.1 Slip rings must be enclosed and protected from any contact by personnel. Means for the provision of this protection is the responsibility of the user. Various enclosure styles are available from Conductix.

1.2.2 **WARNING:** Modification of this equipment may cause excessive wear or failure and will void the warranty.

1.2.3 **WARNING:** Modification may cause safety and fire hazards. Contact the manufacture regarding any modifications which could affect safety or reliability.

1.3 Maintenance Warnings

1.3.1 Exercise care while servicing, adjusting, and operating the slip ring.

1.3.2 Periodically check all fasteners and hardware to assure tightness.

1.3.3 Install all mounting fasteners and hardware so as to maintain tightness under vibration.

1.3.4 If you have any questions about the use or the installation of your R-Series Slip Ring that are not answered in this documentation contact the factory for assistance.

U.S. 1-800-521-4888
Canada: 1-800-667-2487

1.4 Specifications & Listings

1.4.1 R-Series Slip Ring products are built to N.E.C. guidelines and complies to U.L. specifications and are not generally certified or listed by an independent certifying or regulatory body.

1.4.2 The following specifications apply to all R- Series Slip Rings. (Consult factory for in-between sizes)

1.4.2.1 R-Series Slip Rings are intended for industrial use and require a permanent mounting means.

1.4.2.2 Standard RPM ratings depend upon bore size and if the slip ring is equipped with or without ball bearings.

Standard RPM Ratings:

Bore Size	RPM w/o BB	RPM w/ BB
1.5"	125	500
2.5"	75	225
4.0"	35	125
8.0"	25	100

Larger than 10.5" bore size: Consult Factory

1.0 SAFETY (continued)

1.5 Temperature & Ampere / Voltage Ratings

1.5.1 Standard R-Series Slip Ring is rated to withstand a maximum ambient temperature of 220°F., 104°C.

1.5.2 The actual amperage/voltage rating of the Slip Ring assembly is noted on the label. Connections to the assembly must be sized to the ratings of the circuit (*refer to NEC table 310-16, 17, 18, 19 and applicable notes*).

1.6 Markings

1.6.1 Every slip ring is marked with a label on the outboard bearing (or enclosure) which includes the Conductix name and logo, the product catalog number and the individual product serial number.

1.6.2 The marking on slip rings include the maximum amperage and voltage.

2.0 INSTALLATION

2.1 Handling

2.1.1 **NOTE: NEVER SUPPORT UNIT BY CORE AND/OR BRUSH LEADS**

2.1.2 Carry unit by horizontally supporting outboard bearings.

2.2 Application Types

2.2.1 Slip ring assemblies can be purchased with or without an enclosure.

Such Enclosures are:

- wrap around shroud
- revolving enclosure with shaft flange
- stationary enclosure with rotating elbow

Note: User must enclose the slip ring appropriately to meet safety codes and to protect ring.

2.3 Mounting

2.3.1 General Instructions for all Assemblies

2.3.1.1 Slip ring assemblies are to be mounted on the center axis of the application.

2.3.1.2 Unenclosed slip ring assemblies are made up of two basic components, the brush carriage and the core. The brush carriage is made up of the brush posts, brushes, brush holders, and outboard bearings. The core is made up of the rings, insulators, drive collar, ball or friction type bearings, and leads extending from the end on the outside of the through bore. (*See figure 1*)

2.3.1.3 The slip ring assembly is a through bore design and is to be mounted onto a shaft by the set screws in the drive collar.

2.3.1.4 The slip ring assembly can be operated with either the brush carriage or the slip ring core rotating and the other stationary. One of these elements must be stationary in relationship to the other for proper operation. This is called “driving” the ring. **Note: The term “driving” is referring to holding stationary or rotating either the brush carriage or the core.**

2.3.1.5 The brush carriage on a standard slip ring assembly has drive holes in the outboard bearings (*see figure*).

2.3.1.6 Unenclosed slip ring assemblies and assemblies with a wrap around cover(s) can be installed with either the brush carriage or core rotating. One of these items must be held stationary in relationship to the other for proper operation.

2.3.1.7 On enclosed slip ring assemblies, the brush carriage is driven by the enclosure and the core is driven by the shaft. One of these items is to be held stationary in relationship to the other for proper operation.

2.3.1.8 Due to some types of applications and/or the size of the slip ring assembly, the brush carriage maybe required to be driven from both ends. Driving the brush carriages from both ends will prevent the brush carriage from racking or twisting. Special slip ring assemblies may have a special drive arm type device(s) for driving the brush carriage.

2.3.1.9 When driving and to avoid putting strain on the slip ring assembly, the brush carriage and core **MUST be driven by a “loose link” or “floating” type drive connection or mechanism.** Meaning that there is to be “play” between one of the slip ring driven items, which is either the brush carriage or core, and the device that is driving it.

2.3.1.10 **Note: The “loose link” or “floating” type drive connection or mechanism is required due to run-out and or deflection that may occur during operation. If this is not followed, premature wear or failure of the slip ring assembly will occur.**

2.0 INSTALLATION (continued)

2.3.2 Un-enclosed slip ring assemblies and slip ring assemblies with wrap around covers.

2.3.2.1 Install the slip ring assembly on the shaft and lock into place with set screws provided in the drive collar. The mounting shaft must extend at least 80% of the length of the slip ring assembly core. It is recommended to dog point the shaft for the drive collar set screws when mounting the assembly onto the shaft to prevent the core from coming loose. Slip ring assembly can be mounted with either the core or brush carriage rotating.

2.3.2.2 When driving the slip ring assembly, locate the torque arm, bar, pin, bolt, or suitable member to loosely capture the drive holes in the outboard bearings or drive slots along the outside of the brush carriage. To avoid putting strain on the assembly, the drive connection must be a "loose link" or "floating" type drive connection. Because of the run-out and or deflection that may occur during operation, there is to be "play" between the slip ring driven item and the device that is driving it.

2.3.2.3 Make electrical connections at lugs on the brush holders and at the ends of core lead wires, buss bars, or at the core lead terminal shaft. Core leads may be cut to desired length at time of installation. If equipped with wrap around cover, route brush leads through the side of the assembly (NPT hub if provided) and connect brush holders or terminal strips. Be sure electrical connections to the brush holders do not interfere or exert tension on the brush holders and/or carriage assembly. We recommend using flexible wire for brush and core lead terminations. All wire sizes and types must be appropriate to the required amperage and voltage (refer to NEC Table 310-16, 17, 18, 19 and applicable notes).

2.3.2.4 **WARNING: During installation of the slip ring, proper air gap must be maintained between conductive items, all all terminal connections. Refer to U.L. 508 standards.**

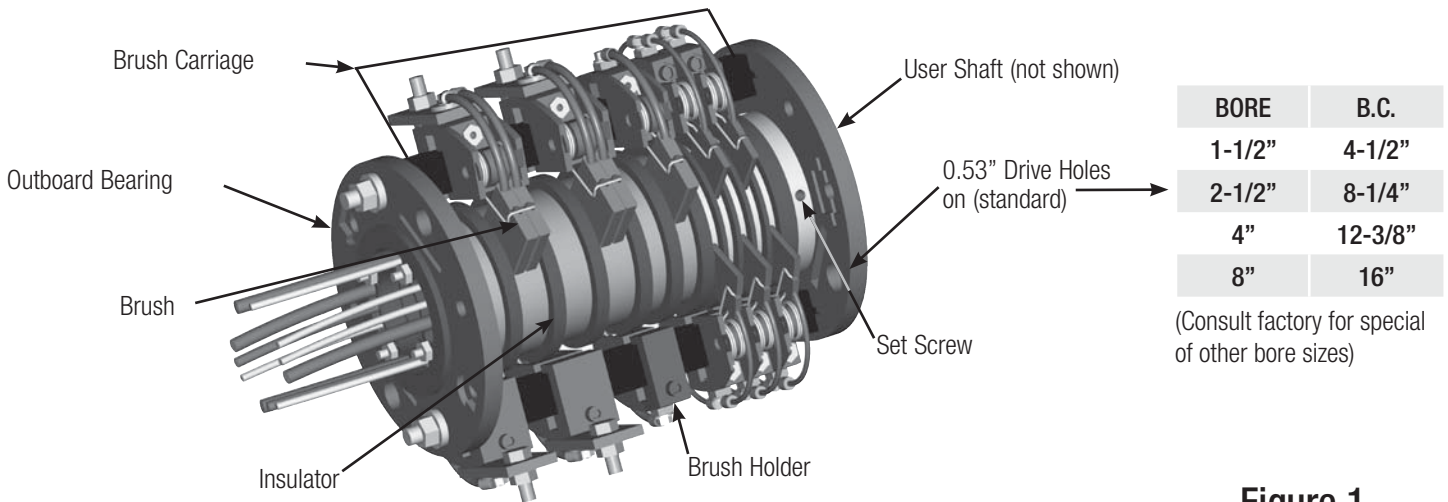

Figure 1

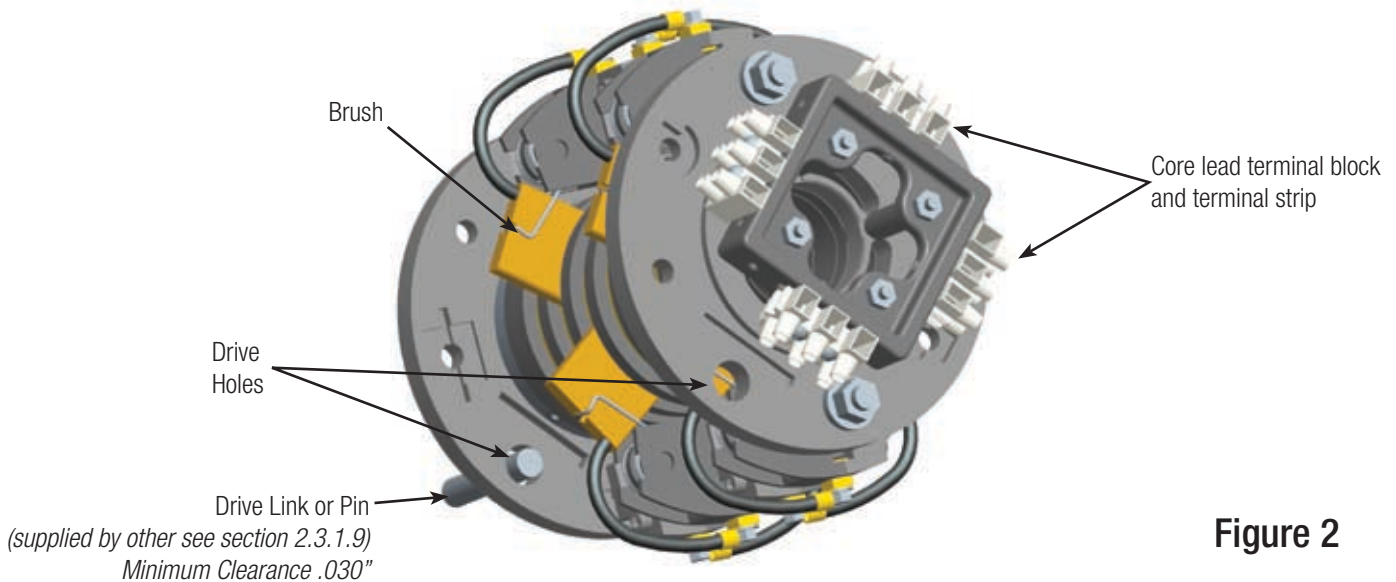

Figure 2

2.0 INSTALLATION (continued)

2.3.3 Slip Ring in Revolving Enclosure (RU)

2.3.3.1 Mount the assembly by either the shaft flange or internal threads at end of shaft to rotating or stationary point. Can be mounted with either the enclosure or shaft/flange rotating.

2.3.3.2 Slip ring is accessed by removal of enclosure side panels or bolted on cover.

2.3.3.3 Electrical leads to brush carriage of slip ring come through the side of enclosure (NPT hub if provided) and connect to screw connectors on brush holders or terminal strips. Electrical lead connections to the

core of the slip ring come through the middle of the shaft and connect to core leads of the slip ring. (see 2.3.2.3)

2.3.3.4 **Note:** Enclosure to be driven, held stationary or rotating, by means of suitable loose link or floating type of connection such as a mechanical drive arm or the conduit connection. This is to avoid putting strain on the assembly due to the run-out and or deflection that may occur during operation. There is to be “play” between the slip ring driven item and the device that is driving it.

2.3.4 Slip Ring in Swivel Enclosure (SU) (RAQ/RBQ)

2.3.4.1 Mount the enclosure using the mounting straps or mounting flange provided. The assembly can be operated with either the enclosure or swivel rotating.

2.3.4.2 Slip ring is accessed by removal of enclosure side panels or bolted on cover.

2.3.4.3 Connect core electrical leads through the swivel elbow provided. Swivel elbow is either held stationary or rotated with a suitable link mechanism such as mechanical or conduit connection.

2.3.4.4 Electrical leads to brush carriage of slip ring come through the side of enclosure (NPT hub if provided) and connect to brush holders or terminal strips. (see 2.3.2.3).

2.3.4.5 **NOTE:** Enclosure to be driven, help stationary or rotating, by means of a suitable loose link or floating type connection such as a mechanical driven arm or the conduit connection. This is to avoid putting strain on the assembly due to the run-out and or deflection that may occur during operation. This is to be “play” between the slip ring driven item and the device that is driving it.

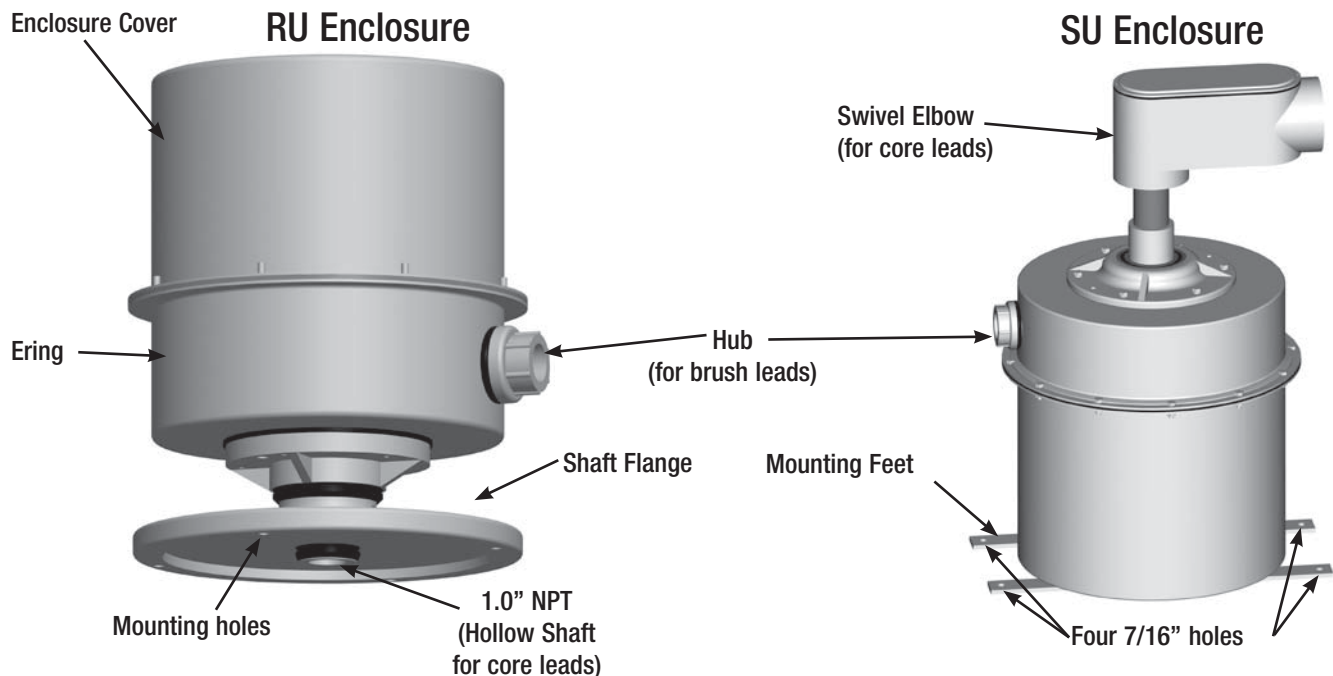

2.0 INSTALLATION (continued)

2.3.5 Explosion Proof Enclosures (XRU, XSU, and XSU with Optional Air Pass)

2.3.5.1 For all explosion proof enclosures, user must seal incoming and outgoing electrical conduit according to the National Electric Code.

2.3.5.2 Slip ring is accessed by removal of enclosure side panels or bolted on cover.

2.3.5.3 For XRU explosion proof assembly mounting and wiring instructions, refer to section 2.3.3: Slip Ring in RU style Revolving Enclosure.

2.3.5.4 For XSU explosion proof assembly mounting and wiring instructions, refer to section 2.3.3: Slip Ring in SU style Revolving Enclosure.

2.3.5.5 **NOTE:** Enclosure to be driven, held stationary or rotating, by means of a suitable loose link or floating type of connection such as a mechanical drive arm or the conduit connection. This is to avoid putting strain on the assembly due to the run-out and or deflection that may occur during operation. The is to be “play” between the slip ring and the device that is driving it.

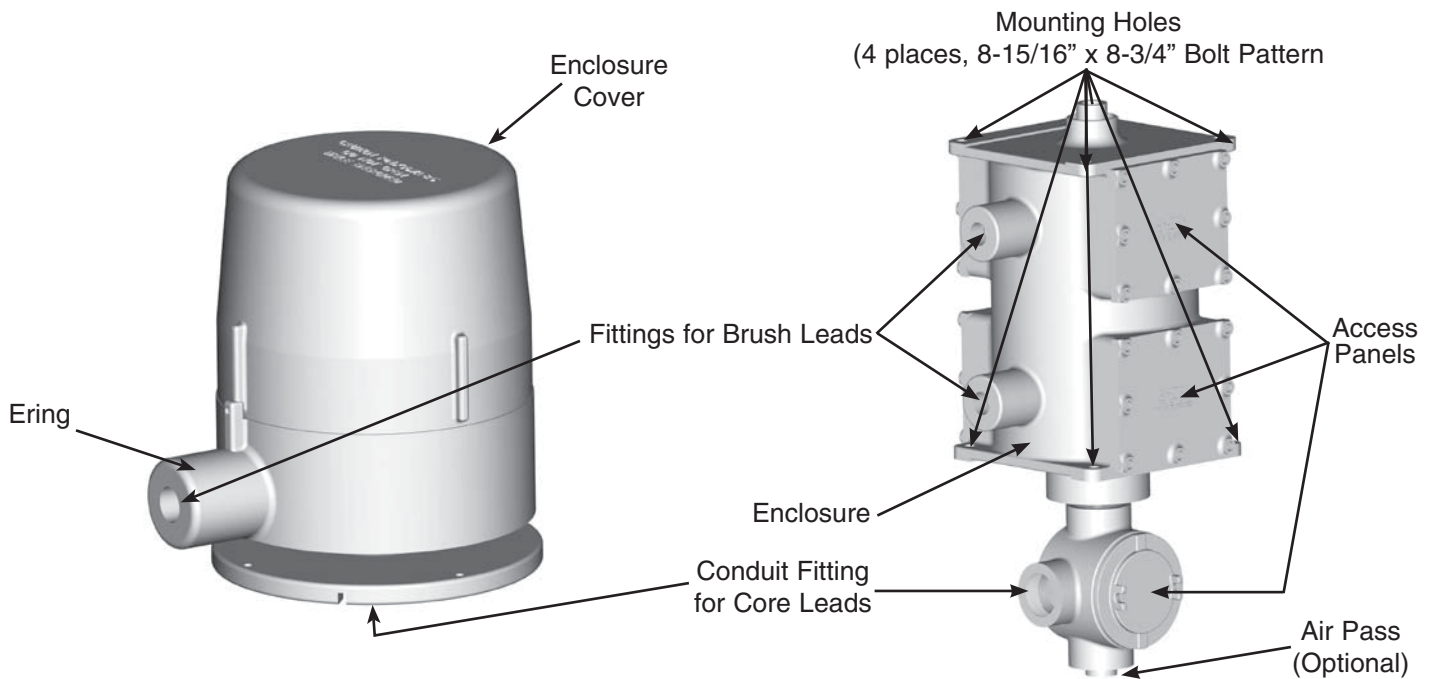

2.4 Wiring and Connections

2.4.1 Perform all wiring according to National Electrical Code guidelines and any applicable local codes.

2.4.2 The connectors in the optional core lead terminal blocks require 5/16" of stripped insulation.

2.4.3 The optional core lead terminal block provides connections to the rings. Use the appropriate crimp connectors if the terminal block is not supplied.

2.4.4 Screws used in the electrical connections must be tightened to achieve the designed electrical rating.

2.4.5 Make connections with stranded wire whenever possible.

2.4.6 Brush lead connections are numbered to corresponding core lead connections. Wire connections accordingly.

2.4.7 For wiring the optional with thermostat: from the power source, connect one lead to the power source, connect one lead to the power and the other lead to the neutral or negative (power in and power out).

NOTE: if the thermostat is supplied separate from the heater, the thermostat is to be wired in series with the power lead.

WARNING: During installation of the slip ring, proper air gap must be maintained between conductive items, and all terminal connections. Refer to U.L. 508 standards

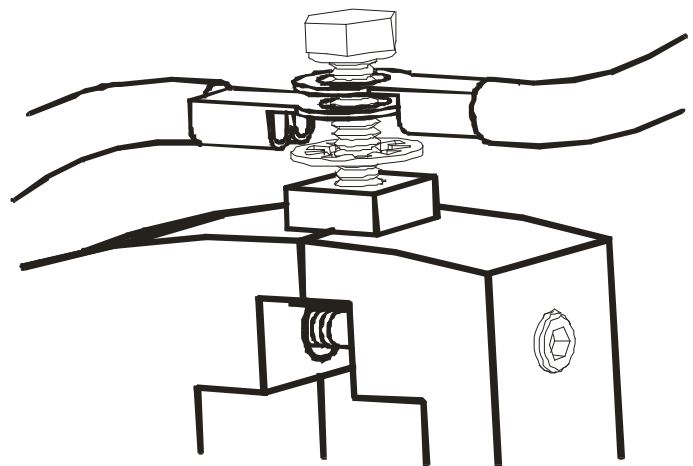

3.0 MAINTENANCE

3.1 Lubrication

3.1.1 All bearings are lubricated for life at the factory. Additional lubrication should not be required.

3.1.2 CAUTION: Do not apply any lubricants or solvent cleaning agents to any part of the slip ring. Use only dry air to clean slip ring assembly.

3.2 Inspections

3.2.1 Before performing inspections and maintenance procedures, insure all power is disconnected and all safety procedures (lock-out / tag-out) are followed.

3.2.2 Make the first inspection shortly after installation and/or operation to insure all electrical connections are tight and all mechanical items are properly adjusted. Make continuing preventative inspections on a regular basis after every 200 - 400 hours of operation under normal conditions. The need for periodic preventative maintenance inspections can be tailored and/or varied depending on the application requirements

3.3 Brush Holders

3.3.1 Inspect brush holders for proper alignment. Locate brush holders so that the entire brush contact surface rides squarely on the ring with the brush moving freely in the brush holder. Position brush holders so the brush makes contact with the middle of the conductor and is not offset.

3.3.2 Check brush holder clamps for tightness. Set clamp bolt at 10 in-lb. max.

3.3.3 Inspect brush terminations at the holder to assure that no external force is imposed on the holder. We recommend flexible or soft wire leads for these terminations. Use external clamps to support the entire weight of the leads.

3.4 Brushes

3.4.1 Inspect for wear. If the distance from the top of the insulator to the lower part of the brush spring is 0.093" or less, replace the brush.

3.4.2 Inspect brush contact surface by removing the brush if required. Remove surface dirt, oxidation, pitting, or other contaminant's by using a brass or poly brush or 320 grit sand paper. Slip ring cleaning kit available (see section 7.0). Care is to be taken not to load-up the brush surface with dust or contaminants.

3.4.3 To remove and replace brush on square post mounted brush holder:

- 1) Remove the brush shunt lead and brush lead wiring from top of brush holder by removing top terminal screw.
- 2) Lift spring slightly with a hook type tool.
- 3) Tilt brush out from under the spring and away from holder for removal.
- 4) To reassemble, replace the brush in the reverse fashion.

3.4.4 To remove and replace brush holder assembly on square post:

- 1) Remove the brush shunt and brush lead wiring from top of brush holder by removing top terminal screw.
- 2) Lift spring slightly with a hook type tool.
- 3) Tilt brush out from under the spring and away from holder for removal.

- 4) Remove Allen screw located on side of holder between top terminal screw and spring.
- 5) Remove holder assembly from post.
- 6) To reassemble, replace the assembly in the reverse fashion. Set clamp bolt at 10 in-lb. max.

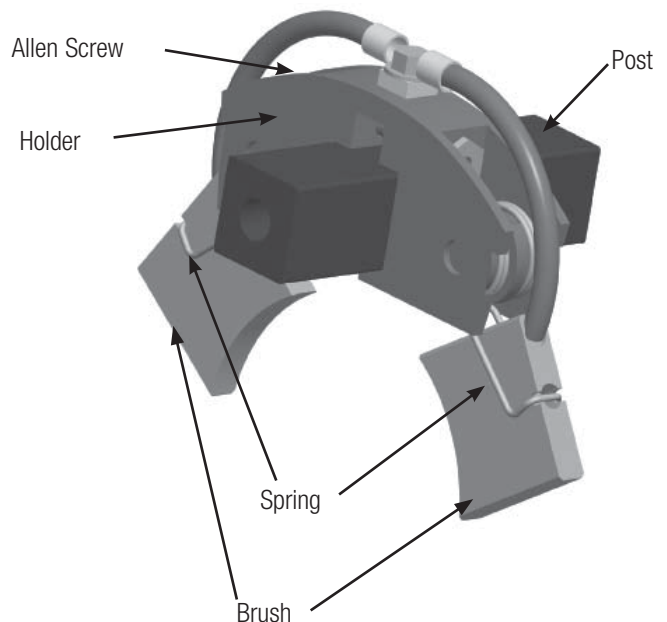

3.0 MAINTENANCE (continued)

3.4.5 To remove and replace metal type DF style brush holder assembly on fiberglass brush post:

- 1) Remove the brush shunt leads and brush lead wiring from top of brush holder by removing cable connection bolts and or lugs.
- 2) Remove top brush holder clamp.
- 3) Slide the remaining brush assembly frame out from under the brush post.
- 4) To reassemble, replace assembly in the reverse fashion. Torque clamp bolts to 96 in lbs.

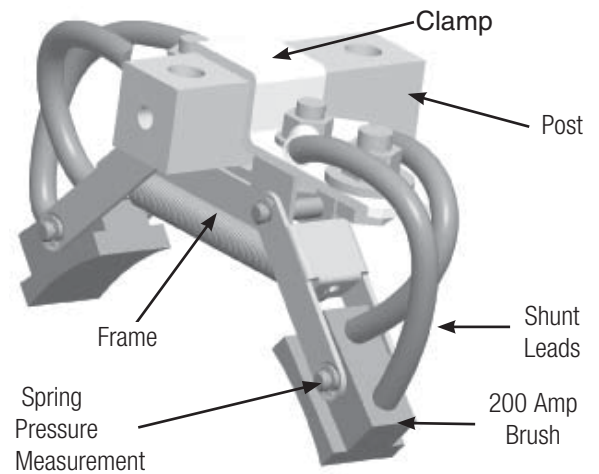

3.5 Brush Fit Inspection

3.5.1 Brushes must run at $90^\circ + 3^\circ$ square on the rings. If brush is not square, adjust position of brush holder on brush post.

3.5.2 Brushes need not run on the center of the rings, but there should be no forceful friction against the insulators.

3.5.3 The brush spring cross-bar must be seated in the brush slot.

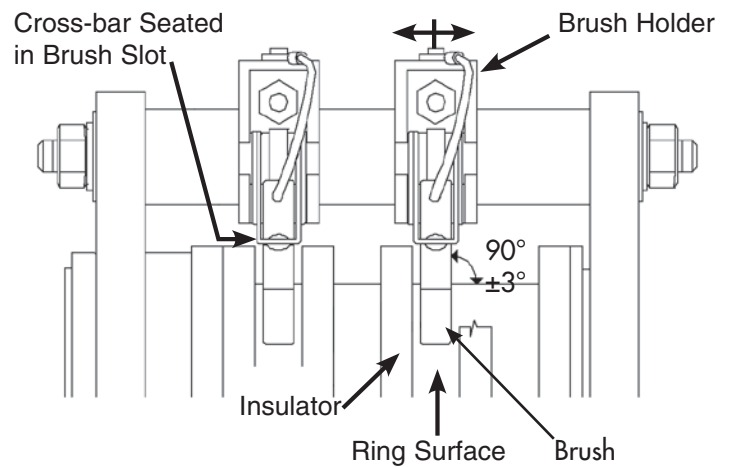

3.6 Brush Springs

3.6.1 Inspect and test brush springs to assure uniform brush pressure. If brush springs fall below recommended pressure, replace entire brush holder.

Table 3.3.3 Brush Spring Tension

Brush	Spring
15	1.0 lb. min
35	1.5 lbs. min
75	3.0 lbs. min
200	2.5 lbs. min

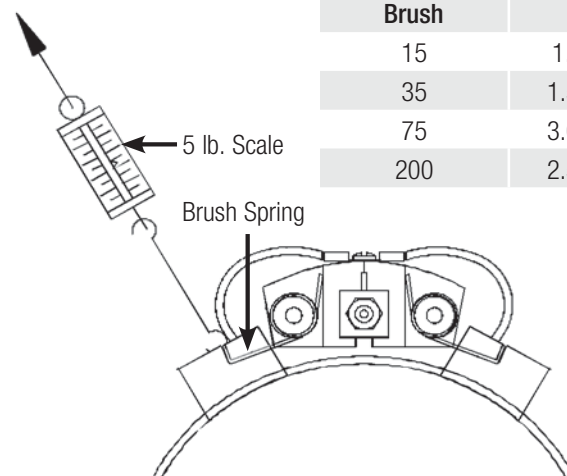

3.7 Rings

3.7.1 Inspect the ring surface for dirt, oxidation, or other contaminant's. A properly operating ring will have a film that appears burnished in color with a darker surrounding color where the brushes track. If the ring requires cleaning, order Slip Ring Polishing Kit Part No. 41286.

3.8 Electrical Connections

3.8.1 Inspect all electrical connections for corrosion and tightness. Loose and/or corroded terminations will cause a concentration of excessive heat.

3.0 MAINTENANCE (continued)

3.9 Brush Rigging

3.9.1 Brush posts are supported between two outboard bearings. The brush posts extend to the outboard bearings and are secured by a notch in the outboard bearing. The notch prevents rotation of the brush post.

3.9.2 Spacing between the outboard bearings is critical to assure the free rotation of the brush carriage rigging. The brush posts are cut to an

exact length in order to provide the proper spacing. Locate the outboard bearings against the insulator and have a 0.20" clearance without deformation of the material.

Caution: Do not overtighten the outboard brush post jam nuts. Make a final check to assure there is no binding of the outboard brush rigging or binding of the brushes with insulator barriers.

3.10 Enclosure Inspection

3.10.1 Moisture is a major cause of slip ring deterioration. Water will corrode parts and breakdown insulation. Dust and dirt present within the enclosure will effect the proper operation of the assembly. Most dusts cause excessive brush and slip ring wear, and conductive dust, if allowed to accumulate will form a path for short circuiting.

3.10.2 A properly designed NEMA 4 enclosure will be dust tight and watertight. However, NEMA 4 enclosures do not eliminate internal condensation. Condensation can be eliminated with the addition of a breather, drain and a thermostatically controlled heater. Consult factory for details.

3.10.3 Periodically perform an inspection by removing the enclosure and checking for condensation, water and dust collection. If contaminant's are found, wipe the enclosure and the assembly with a lint free cloth. If the problem persists, take steps to remedy the leakage or condensation problem.

3.11 Cleaning

3.11.1 In addition to using the slip ring polishing kit #41286 when cleaning the slip ring assembly, use only clean dry low pressure air or a vacuum cleaner to remove the contaminants from the rings. Do not use any solvents, aerosol sprays, or liquid cleaners on the slip ring assembly.

4.0 STORAGE

4.1 When storing the slip ring, keep it at room temperature in a clean, dry protective place. Place selfcontained or bagged absorbent material in the collector ring enclosure during extended periods of storage. Remove absorbent material before putting collector ring into operation.

5.0 SERIAL NUMBER RECORD

5.1 Make the following information available when ordering replacement parts or discussing the slip ring with the factory by recording the information in the spaces provided here. This information is located on your packing slip, factory invoice, and serial number tag.

Catalog No. Slip Ring: _____

Serial No.: _____

Date of Purchase: _____

6.0 TROUBLESHOOTING

6.1 Some possible problems are addressed in the table here, otherwise, contact the factory at the numbers provided on the back page.

Problem	What to Check
Intermittent Signal or Loss of Signal	Verify brush wear per Section 3.2.3
	Check spring pressure per Section 3.2.4
	Check contact surfaces for cleanliness. (Ring Polishing Kit available. See Replacement Parts.)
	Visually check for spring fit and function. Adjust or replace as necessary
	Check core wiring for short circuit

7.0 REPLACEMENT PARTS

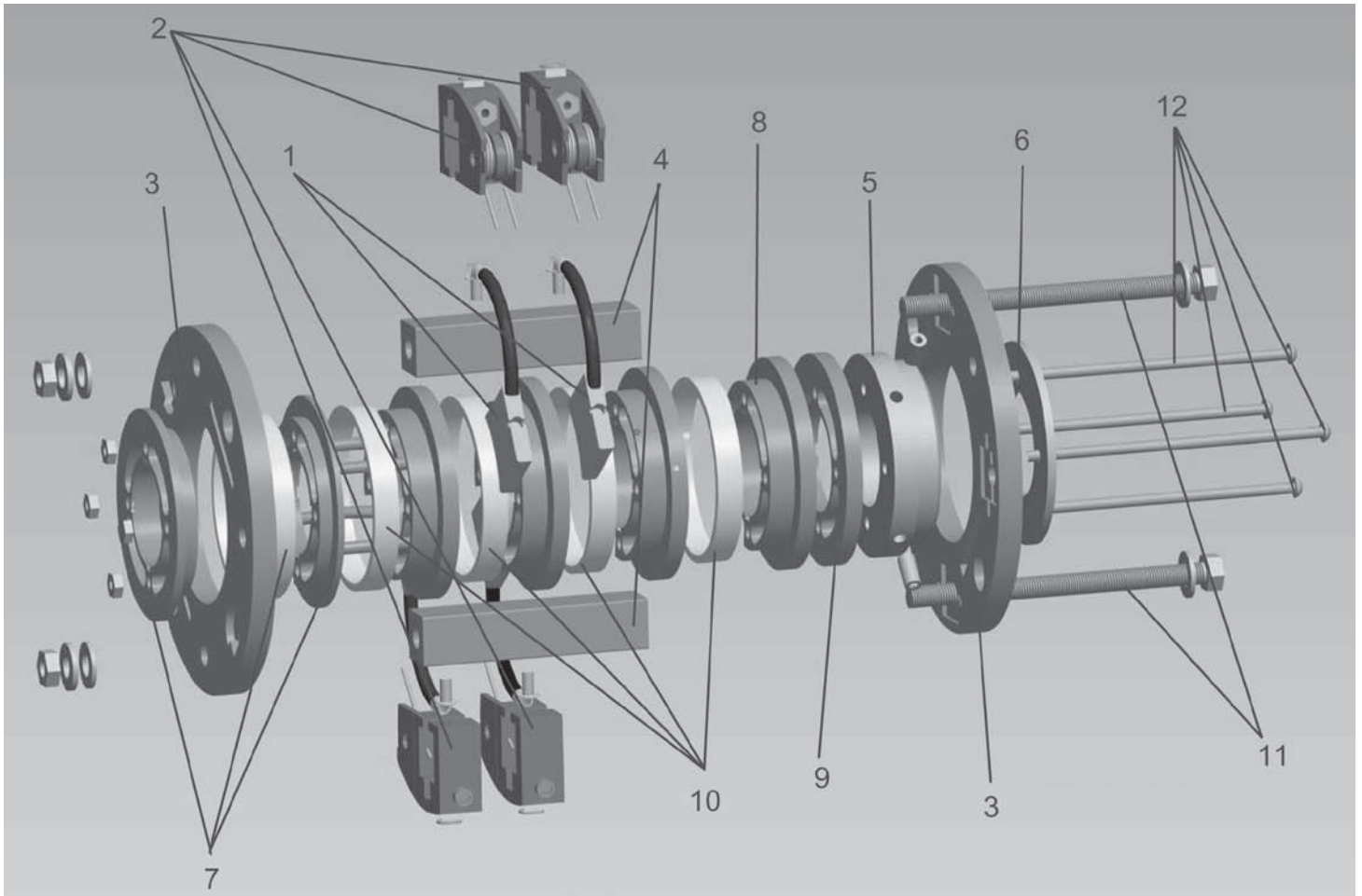

NOTE: Always have Part and or Serial Number when ordering

Slip Ring Cleaning Kit: Part No. 41286

ITEM #1 Brushes

AMPERAGE	Slip Ring Bore Sizes			
	1.5"	2.5", 3.0", 3.5"	4.0", 4.5", 5.0", 6.0" 6.5"	8.0", 10.0", 10.5"
15 Amp Signal Circuits	30067A	30067B	30067C	30067D
15 Amp	30066A	30066B	30066C	30066D
35 Amp	30068A	30068B	30068C	30068D
75 Amp	30069A	30069B	30069C	30069D
110 Amp	02840	02845	02850	02855
150 Amp	02841	02846	02851	02856
200 Amp	N/A	DRA3-20A-2500	DRA3-20A-4000	DRA3-20A-8000
225 Amp	N/A	02847	02852	02857
300 Amp	N/A	02848	02853	02858
400 Amp	N/A	DRA3-20A-2500x2	DRA3-20A-4000x2	DRA3-20A-8000x2
600 Amp	N/A	DRA3-20A-2500x3	DRA3-20A-4000x3	DRA3-20A-8000x3

7.0 REPLACEMENT PARTS (continued)

ITEM #2 Brush Holders		
AMPERAGE	Single	Double
15 Amp	02800	02807
35 Amp	02801	02808
75 Amp	02802	02809
110 Amp	02803	02810
150 Amp	02804	02811
225 Amp	02805	02805(x2)
300 Amp	02806	02806(x2)
200 Amp		
400 Amp		
600 Amp		

Brushes and holders are sold as a single unit
in these amp ranges

	ITEM #3	ITEM #4	ITEM #5	ITEM #6	ITEM #7
Bore Diameter	Out Board Bearing (C/F)	Brush Post Material	Drive Collars	Retaining Ring	Bearing Ring w/insulator (C/F)
1.5"	30061	100505 *To be cut to length at time of assembly	30121	30015Z	41188
2.5"	30079Z		R60A-K	N/A	100200
3.0"	30079Z		R60A3-DK	N/A	100203
3.5"	30079Z		R60A3.5-DK	N/A	R498/R392-8A-35
4.0"	30073		R515-DTK	N/A	R559/R469-8A
4.5"	30073		R515-DTK-4.5	N/A	R559/R469-8A-45
5.0"	30073		R515-DTK-5.0	N/A	R559/R469-8A-50
6.0"	41353		R515-DTK-6	N/A	R559/R469-8A-6
8.0"	30076		R1345	N/A	100210
10.0"	30076		R1345-10000M	N/A	100186

Special bore sizes: Consult Factory

C/F= Consult factory is assembly is equipped with ball bearings

7.0 REPLACEMENT PARTS (continued)

ITEM #8 *(see also SPACERS for circuits rated 110AMPS and above)

Amps/Voltage	Slip Ring Bore Size				
	1.5"	2.5"	3.0"	3.5"	4.0"
15A/250V Silver	R983	R392-B-2500	R392-4A-3000-M	R392-B-3500	R469-B-4000
15A/250V	R983	R392-B-2500	R392-4A-3000-M	R392-B-3500	R469-B-4000
35A/250V	R27-4D	R392-4A	R392-4A-3000-M	R392-4A-3500	R469-4A
35A/600V	R27-4E	R392-4A	R392-4A-3000-M	R392-4A-3500	R469-4A
75A/600V	R27-8C	R392-8A	R392-8A-3000-M	R392-8A-3500	R469-8A
110A/600V	R27-4E	R392-4A	R392-4A-3000-M	R392-4A-3500	R469-4A
150A/600V	N/A	R392-8A	R392-8A-3000-M	R392-8A-3500	R469-4A
200A/600V	N/A	R392-8A	R392-8A-3000-M	R392-8A-3500	R469-8A
225A/600V	N/A	R392-8A	R392-8A-3000-M	R392-8A-3500	R469-8A
300A/600V	N/A	R392-8A	R392-8A-3000-M	R392-8A-3500	R469-8A
400A/600V	N/A	R392-8A	R392-8A-3000-M	R392-8A-3500	R469-8A
600A/600V	N/A	R392-8A	R392-8A-3000-M	R392-8A-3500	R469-8A
	Slip Ring Bore Size				
	4.5"	5.0"	6.0"	8.0"	10.0"
15A/250V Silver	R469-B-4.5	R469-B-5000	R469-B-6000	R1191-4	R1191-4-10000
15A/250V	R469-B-4.5	R469-B-5000	R469-B-6000	R1191-4	R1191-4-10000
35A/250V	R469-4A-4.5	R469-4A-5000	R469-4A-6000	R1191-4	R1191-4-10000
35A/600V	R469-4A-4.5	R469-4A-5000	R469-4A-6000	R1191-4	R1191-4-10000
75A/600V	R469-8A-4.5	R469-8A-5000	R469-8A-6000	R1191-8	R1191-8-10000
110A/600V	R469-4A-4.5	R469-4A-5000	R469-4A-6000	R1191-4	R1191-4-10000
150A/600V	R469-4A-4.5	R469-4A-5000	R469-4A-6000	R1191-8	R1191-8-10000
200A/600V	R469-8A-4.5	R469-8A-5000	R469-8A-6000	R1191-8	R1191-8-10000
225A/600V	R469-8A-4.5	R469-8A-5000	R469-8A-6000	R1191-8	R1191-8-10000
300A/600V	R469-8A-4.5	R469-8A-5000	R469-8A-6000	R1191-8	R1191-8-10000
400A/600V	R469-8A-4.5	R469-8A-5000	R469-8A-6000	R1191-8	R1191-8-10000
600A/600V	R469-8A-4.5	R469-8A-5000	R469-8A-6000	R1191-8	R1191-8-10000

7.0 REPLACEMENT PARTS (continued)

SPACERS (not shown in exploded diagram)

Amps/Voltage	Slip Ring Bore Size				
	1.5"	2.5"	3.0"	3.5"	4.0"
15A/250V Silver					
15A/250V					
35A/250V					
35A/600V					
75A/600V					
110A/600V	R27-8M	R392-8M	R392-8M-3000-M	R392-8M-3500	R469-8M
150A/600V	R27-8M	R392-8M	R392-8M-3000-M	R392-8M-3500	R469-8M
200A/600V	N/A	R392-8M	R392-8M-3000-M	R392-8M-3500	R469-8M
225A/600V	N/A	R392-8M	R392-8M-3000-M	R392-8M-3500	R469-8M
300A/600V	N/A	R392-8M	R392-8M-3000-M	R392-8M-3500	R469-8M
400A/600V	N/A	R392-8M	R392-8M-3000-M	R392-8M-3500	R469-8M
600A/600V	N/A	R392-8M	R392-8M-3000-M	R392-8M-3500	R469-8M
	Slip Ring Bore Size				
	4.5"	5.0"	6.0"	8.0"	10.0"

*Spacers are required in conjunction with insulators (Item #8) on circuits rated 110 Amps and above.

*Spacers are required in conjunction with insulators (Item #8) on circuits rated 110 Amps and above. R469-8M-4500

15A/250V Silver					
15A/250V					
35A/250V					
35A/600V					
75A/600V					
110A/600V	R469-8M-4500	R469-8M-5000	R469-8M-6000	R1191-8M	R1191-8M-10000
150A/600V	R469-8M-4500	R469-8M-5000	R469-8M-6000	R1191-8M	R1191-8M-10000
200A/600V	R469-8M-4500	R469-8M-5000	R469-8M-6000	R1191-8M	R1191-8M-10000
225A/600V	R469-8M-4500	R469-8M-5000	R469-8M-6000	R1191-8M	R1191-8M-10000
300A/600V	R469-8M-4500	R469-8M-5000	R469-8M-6000	R1191-8M	R1191-8M-10000
400A/600V	R469-8M-4500	R469-8M-5000	R469-8M-6000	R1191-8M	R1191-8M-10000
600A/600V	R469-8M-4500	R469-8M-5000	R469-8M-6000	R1191-8M	R1191-8M-10000

ITEM #9 Barrier

Only 1.5" bore slip rings have barriers next to the outboard bearings

Barrier Part Number R27-B

ITEM #10 Z-Ring

Consult Factory for individual replacement rings

ITEM #11 Brush Post Bolts

Consult Factory for replacement brush holder bolts

ITEM #12 Core Bolts

Consult Factory for replacement core bolts

www.conductix.com

Conductix-Wampfler

10102 F Street
Omaha, NE 68127
USA

Customer Support
Phone: 800 521 4888
Fax: 800 780 8329

Phone: 402 339 9300
Fax: 402 339 9627

info.us@conductix.com
www.conductix.com

