

Hazardous Duty Cable Reels 2500 Series

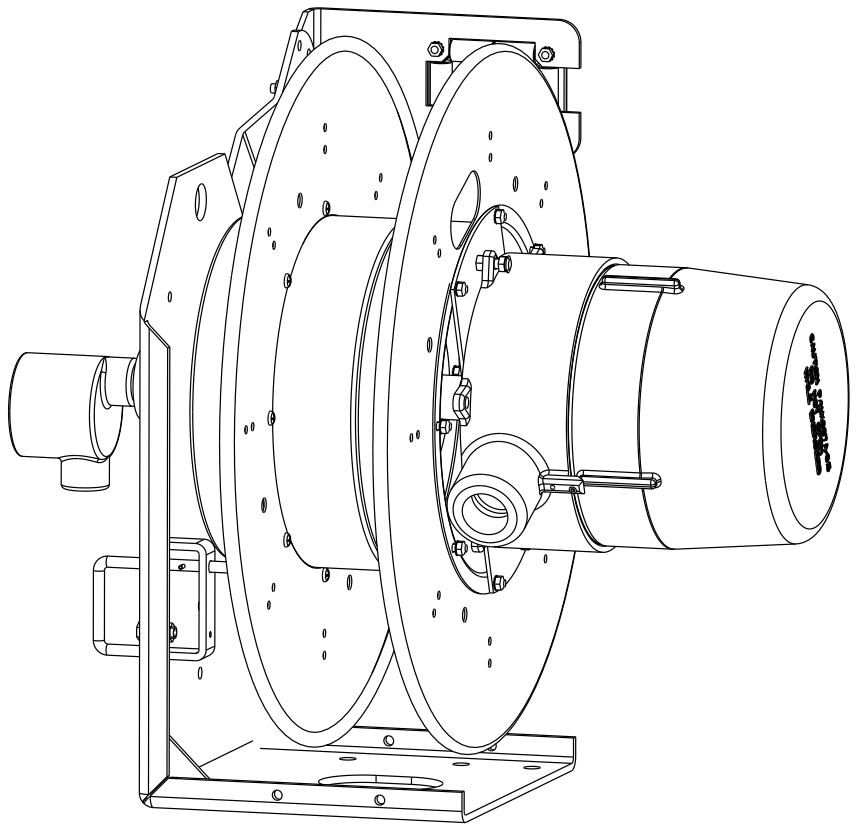

Conductix Incorporated

The technical data and images which appear in this manual are for informational purposes only. **NO WARRANTIES, EXPRESS OR IMPLIED, INCLUDING WARRANTIES OF MERCHANTABILITY OR FITNESS FOR A PARTICULAR PURPOSE, ARE CREATED BY THE DESCRIPTIONS AND DEPICTIONS OF THE PRODUCTS SHOWN IN THIS MANUAL.** Conductix makes no warranty (and assumes no liability) as to function of equipment or operation of systems built according to customer design or of the ability of any of its products to interface, operate or function with any portions of customer systems not provided by Conductix.

Seller agrees to repair or exchange the goods sold hereunder necessitated by reason of defective workmanship and material discovered and reported to Seller within one year after shipment of such goods to Buyer.

Except where the nature of the defect is such that it is appropriate, in Seller's judgment, to effect repairs on site, Seller's obligation hereunder to remedy defects shall be limited to repairing or replacing (at Seller's option) FOB point of original shipment by Seller, any part returned to Seller at the risk and cost of Buyer. Defective parts replaced by Seller shall become the property of Seller.

Seller shall only be obligated to make such repair or replacement if the goods have been used by Buyer only in service recommended by Seller and altered only as authorized by Seller. Seller is not responsible for defects which arise from improper installation, neglect, or improper use or from normal wear and tear.

Additionally, Seller's obligation shall be limited by the manufacturer's warranty (and is not further warranted by Seller) for all parts procured from others according to published data, specifications or performance information not designed by or for Seller.

Seller further agrees to replace or at Seller's option to provide a refund of the sales price of any goods that do not conform to applicable specifications or which differ from that agreed to be supplied which non-conformity is discovered and forthwith reported to Seller within thirty (30) days after shipment to the Buyer. Seller's obligation to replace or refund the purchase price for non-conforming goods shall arise once Buyer returns such goods FOB point of original shipment by Seller at the risk and cost of Buyer. Goods replaced by Seller shall become the property of Seller.

There is no guarantee or warranty as to anything made or sold by Seller, or any services performed, except as to title and freedom from encumbrances and, except as herein expressly stated and particularly, and without limiting the foregoing, **there is no guarantee or warranty, express or implied, of merchantability or of fitness for any particular purpose or against claim of infringement or the like.**

Seller makes no warranty (and assumes no liability) as to function of equipment or operation of systems built to Buyer's design or of the ability of any goods to interface, operate or function with any portions of Buyer's system not provided by Seller.

Seller's liability on any claim, whether in contract, tort (including negligence), or otherwise, for any loss or damage arising out of, connected with, or resulting from the manufacture, sale, delivery, resale, repair, replacement or use of any products or services shall in no case exceed the price paid for the product or services or any part thereof which give rise to the claim. In no event shall Seller be liable for consequential, special, incidental or other damages, nor shall Seller be liable in respect of personal injury or damage to property not the subject matter hereof unless attributable to gross misconduct of Seller, which shall mean an act or omission by Seller demonstrating reckless disregard of the foreseeable consequences thereof.

Seller is not responsible for incorrect choice of models or where products are used in excess of their rated and recommended capacities and design functions or under abnormal conditions. Seller assumes no liability for loss of time, damage or injuries to property or persons resulting from the use of Seller's products. Buyer shall hold Seller harmless from all liability, claims, suits and expenses in connection with loss or damage resulting from operation of products or utilization of services, respectively, of Seller and shall defend any suit or action which might arise there from in Buyer's name - provided that Seller shall have the right to elect to defend any such suit or action for the account of Buyer. The foregoing shall be the exclusive remedies of the Buyer and all persons and entitles claiming through the Buyer.

1.0 Safety

- 1.1 Electrical Warnings
- 1.2 Operational Warnings
- 1.3 Maintenance Warnings
- 1.4 Specifications and Listings
- 1.5 Electrical Rating
- 1.6 Labels and Marking

2.0 Installation

- 2.1 Application Types
- 2.2 Mounting
- 2.3 Guide Rails
- 2.4 Roller Guides
- 2.5 Ratchet
- 2.6 Spool Lock
- 2.7 Spring Tension Adjustment

3.0 Operation

4.0 Maintenance

- 4.1 Maintenance Warnings
- 4.2 Lubrication
- 4.3 Inspections

5.0 Replacement Parts

- 5.1 Slip Ring Part Descriptions
- 5.2 Reel Part Descriptions

6.0 Troubleshooting

RECORD

The catalog number of the reel and the serial number of the reel are required when ordering replacement parts or discussing the reel with the factory. Please record this information now in the spaces provided below.

CATALOG NO. OF REEL _____

SERIAL NO. _____

DATE INSTALLED _____

Basic Component Identification

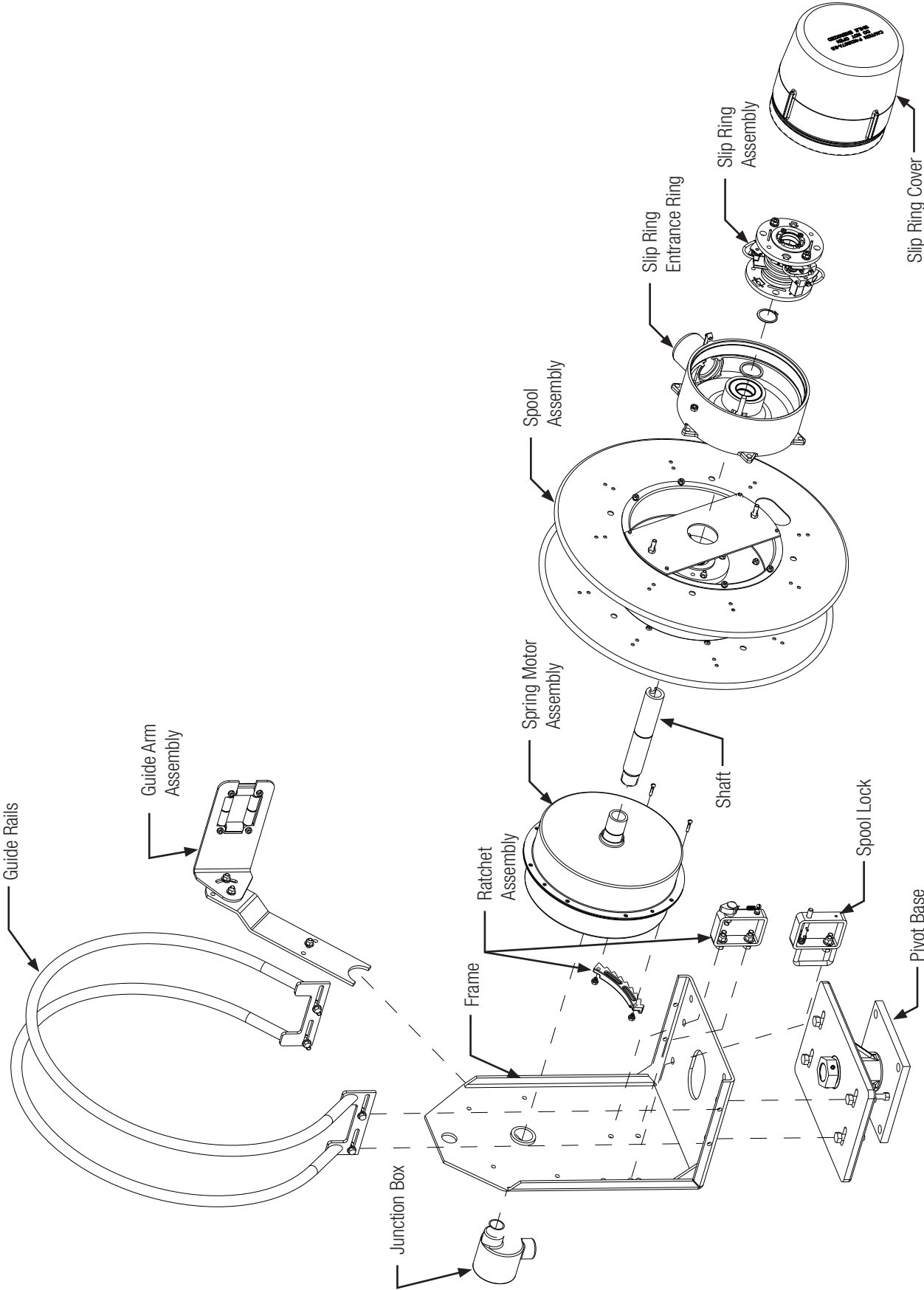

1.0 Safety

1.1 Electrical Warnings

- 1.1.1 This equipment should be properly grounded before use, in accordance with both the National Electric Code and local codes and ordinances.
- 1.1.2 The electrical power should be disconnected from the cable reel before any service functions are performed.
- 1.1.3 This cable reel must not be used for loads greater than the voltage and current rating of the cable. The ampacity rating of the cable reel shall be in accordance with the National Electric Code.

1.2 Operational Warnings

- 1.2.1 Exercise care when handling the cable reel during normal operation. This cable reel has a rotating spool powered by springs under tension.
- 1.2.3 Do not use cable different from that for which the reel is intended. Changes in diameter, weight per foot, length of cable or flexibility will affect the operation of the reel.
- 1.2.4 Mounting hardware and fasteners should be installed to maintain tightness under vibration and checked periodically to assure tightness.
- 1.2.5 Overhead installation mountings should be such that the reel is not supported by bolts in tension. A safety chain or cable is strongly recommended to minimize damage and/or possible injury in the event of mounting failure.

1.3 Maintenance Warnings

- 1.3.1 **WARNING:** Modification of this equipment may cause excessive wear and will void the warranty. Contact the manufacturer regarding changes or modifications of equipment which could affect reliability or safety.
- 1.3.2 **DO NOT DISASSEMBLE THE SPRING MOTOR FOR ANY REASON.** Serious personal injury could result. This cable reel is equipped with springs under tension. Contact the factory for assistance.

In the US call: 1 800-521-4888

In the Canada call: 1 800-667-2487

1.4 Specifications & Listings

1.4.1 The following specifications apply to standard 2500 Series Cable PowerReels:

- 1.4.2 2500 Series Cable Reels are intended for commercial / industrial use and are provided with a permanent mounting base.
- 1.4.3 2500 Series Cable Reels are built to NEMA 4 specifications and are suitable for indoor/outdoor use.
- 1.4.4 Spring Motors for the 2500 Series are sealed for safety and weather-tight for long-life.
- 1.4.5 Ampere capacity of the 2500 Series Reels range from 10 to 150 Amperes and 600 Volts maximum. Reels are available in 3 to 30 conductor configurations.
- 1.4.6 2500 Series Cable Reels are available with optional features which increase safety, enhance performance, and improve serviceability. Options include: ratchet, pivot base, spool lock, junction box, and guide rails.
- 1.4.7 Custom power and signal circuit slip rings using silver plated slip rings and silver graphite brushes are available on request.

1.0 Safety

1.5 Electrical Rating

1.5.1 All 2500 series reels are equipped with cable:

These reels equipped with flexible cable should not be used at voltages and/or amperages above the rating of the reel or the cable.

1.6 Labels & Marking

1.6.1 Every cable reel is marked with a label on the frame which includes the Conductix name and logo, the product catalog number and the individual product serial number.

1.6.2 The marking on reels equipped with a flexible cable shall include the current and voltage ratings.

1.6.2.1 The maximum amperage and voltage rating for the cable reel is on the Conductix Identification label. Actual rating is determined by the installed cable, wire size and number of conductors, and is not to exceed the indicated maximum rating of the slip ring.

1.6.2.2 The cable reel is designed to handle cable with a temperature rating of up to 90° C, which is marked on the cable.

Table 1.6
Allowable Ampacities for Flexible Cord & Cable

Type W (90°C)	
Cable	Ampacity
W 8/2	50
W 8/3	50
W 8/4	45
W 6/2	65
W 6/3	65
W 6/4	55
W 4/2	90
W 4/3	85
W 4/4	75
W 2/2	120
W 2/3	115
W 2/4	100
W 1/2	140

Type G-GC(90°C)	
Cable	Ampacity
8/3 G-GC	50
6/3 G-GC	65
4/3 G-GC	85
2/3 G-GC	115

Type SOW-A, SOOW-A (90° C)			
Cable	Ampacity	Cable	Ampacity
16/2	13	12/2	20
16/3	10	12/3	20
16/4	8	12/4	16
16/5	8	12/5	16
16/6	8	12/6	16
16/7	7	12/7	14
16/8	7	12/8	14
16/10	7	12/10	14
16/12	7	12/12	14
16/14	7	12/14	14
16/16	7	12/16	14
16/20	7	12/20	14
16/24	6	12/24	14
16/30	6	12/30	12
14/2	15	10/2	25
14/3	15	10/3	25
14/4	12	10/4	20
14/5	12	10/5	20
14/6	12	10/6	20
14/7	10.5	10/7	17.5
14/8	10.5	10/8	17.5
14/10	10.5	10/10	17.5
14/12	10.5	10/12	17.5
14/14	10.5	10/14	17.5
14/16	10.5	10/16	17.5
14/20	10.5	10/20	17.5
14/24	10.5	-	-
14/30	9	-	-

G-GC Cable Color Code Chart		
Cond. No.	Base Color	Tracer Color
1	Green	-
2	Green	-
3	Yellow	-
4	Black	-
5	White	-
6	Red	-

Color Code Chart		
Cond. No.	Base Color	Tracer Color
1	Green	-
2	Black	-
3	White	-
4	Red	-
5	Orange	-
6	Blue	-
7	White	Black
8	Red	Black
9	Green	Black
10	Orange	Black
11	Blue Black	Black
12	Black	White
13	Red	White
14	Green	White
15	Blue	White
16	Black	Red
17	White	Red
18	Orange	Red
19	Blue	Red
20	Red	Green
21	Orange	Green
22	Black	-
23	White	-
24	Red	-
25	Green	-
26	Orange	-
27	Blue	-
28	White	Black
29	Red	Black
30	Green	Black

2.0 Installation

2.1 Application Types

2.1.1 Stretch Applications



2.1.1.1 The cable is suspended without any intermediate support. Stretch reels generally require a line pull equal to two times the weight of the cable, which allows approximately 6% sag. On long applications where sag cannot be tolerated, it is sometimes desirable to put supports at intervals of 5 to 10 feet.

2.1.3 Drag Applications

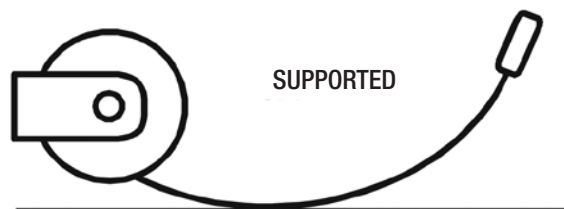

2.1.3.1 The reel is mounted on a stationary object and is required to drag the cable over the surface to the reel. A ratchet and/or ball stop may be desired.



2.1.2 Lift Applications

2.1.2.1 The cable is lifted vertically. The reel is normally designed to handle only the total weight of the cable. Some lift applications may require a ratchet and/or ball stop to control the retracted length of cable.

2.1.4 Retrieve Applications

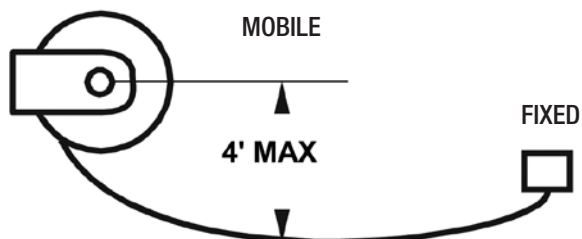

2.1.4.1 The reel is mounted on the moving object and winds up or pays out the cable as the machine approaches or moves away from the power source. Vertical Retrieve applications are possible.

2.2 Mounting

2.2.1 Standard Mounting

2.2.1.1 Mount the base of the reel to any flat surface which is structurally sound enough to support the reel and the forces of winding and unwinding the cable.

2.2.1.2 The spool drum must be mounted horizontally.

2.2.1.3 The cable should extend perpendicular to the rotation of the spool. The total cable deflection should not exceed 15° to either side of the centerline of the spool.

2.2.1.4 If deflection is constant to either side of the reel and operation is impaired, re-mount the reel.

2.2.1.5 If the angle of deflection exceeds 30°, a Pivot Base or two way payout guide should be used, otherwise excessive cable wear and unreliable operation will result.

2.2.1.6 A safety chain is recommended for all overhead installations. Attach the safety chain using the 0.39" hole provided in the base.

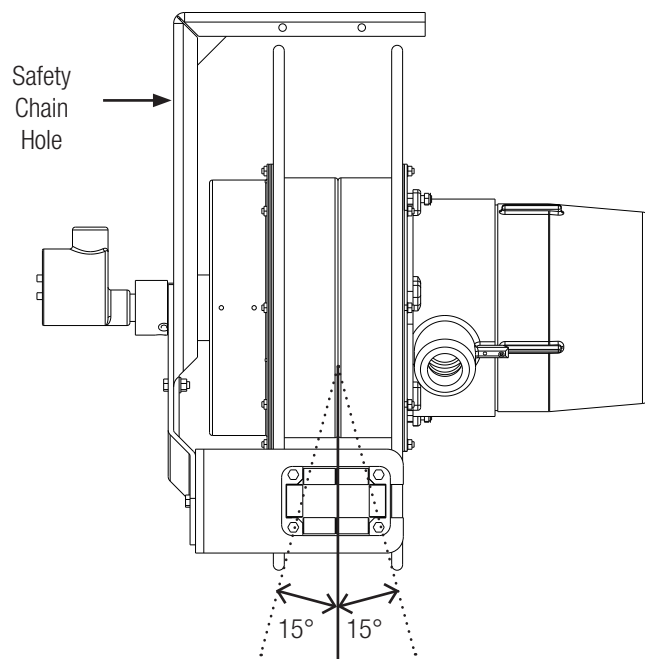

2.0 Installation

2.2.2 Pivot Base Mounting

- 2.2.2.1 All 2500 Series Cable Reels can be furnished with a pivot base to allow the reel to rotate and keep the extended cable perpendicular to the application.
- 2.2.2.2 Pivot Bases rotate up to 345°. If 360° rotation is required contact the factory.
- 2.2.2.3 A pivot base is required in carousel or loop-track applications.
- 2.2.2.4 When a pivot base is used the reel must be mounted horizontally ("ceiling" or "floor" mounted).
- 2.2.2.5 The Roller Guide should be mounted to require the cable to travel perpendicular to the axis of pivot base rotation. This will guard against cable twisting and ensure effective swivel action from the pivot base.
- 2.2.2.6 Mount Pivot Base in the position that best centers the spool over the pivot axis.

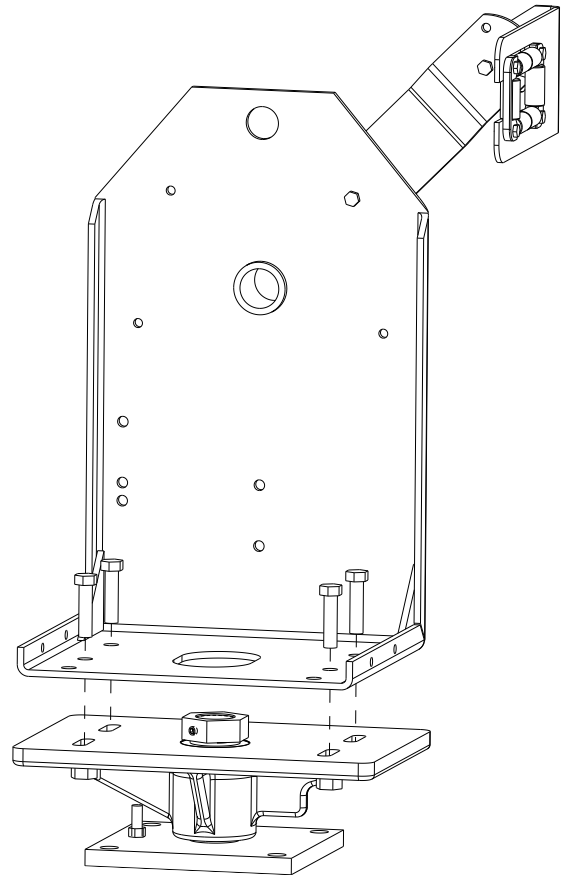

Part Number: 40274X

2.3 Guide Rails

- 2.3.1 The optional guide rails can be installed on any of the 2500 Series Cable Reels.
- 2.3.2 Guide Rails provide a barrier between the cable and the rotating spool flange rim. They also act as a safety barrier for installations where human contact with the rotating spool flange is likely to occur.
- 2.3.3 Guide Rails provide additional assurance that the cable will wrap efficiently on the spool for applications involving rigorous motion.
- 2.3.4 Guide Rails can act as a substitute for the roller guide in applications that require a two-way pay-out.

2.3.5 Guide Rail Installation

- 2.3.5.1 Guide Rails are mounted to the base using the same bolts that mount the reel. **Note: Later versions may have guide rail mounted on sides of base.**
- 2.3.5.2 Mount Rails as shown.

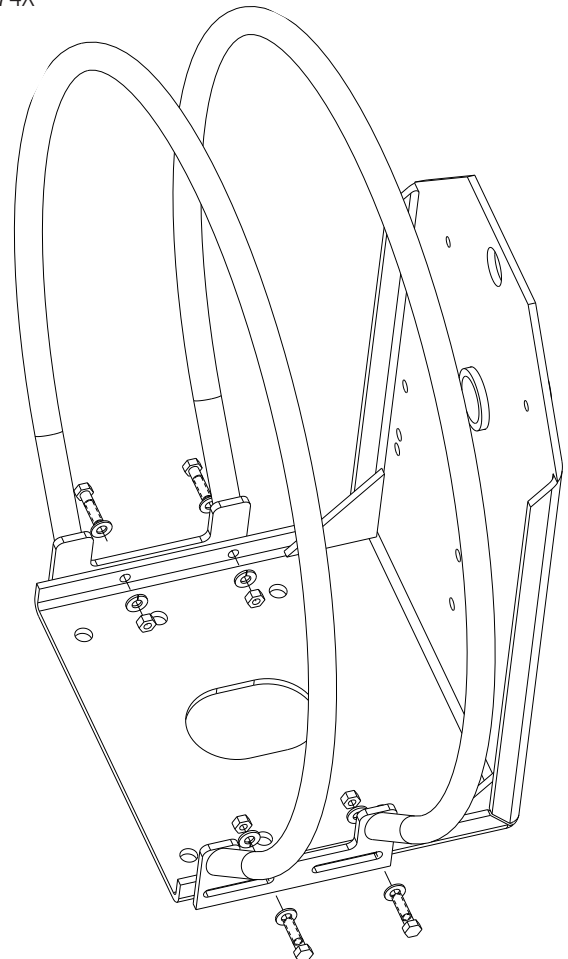

2.0 Installation

2.4 Roller Guides

- 2.4.1 All 2500 Series Cable Reels are equipped with an adjustable Roller Guide. The guide's function is to center the cable on the spool and to help the reel wrap cable more evenly.
- 2.4.2 Level winding is inhibited by the cable bearing against either of the spool flanges during operation. The Roller Guide helps to alleviate this condition.
- 2.4.3 The guide consists of two elements: the guide arm and the guide head. The guide must be adjusted and secured prior to terminating any electrical connections.
- 2.4.4 The guide should be secured at the position that causes the least change of cable direction to occur at the guide; otherwise, cable life will be reduced.
- 2.4.4.1 Mount the guide arm to the base by positioning the open end of the arm against the groove between the shaft coupling and the frame. Secure the guide arm using the provided 5/16-18 hex head cap screw, spring-type lock washer, and 5/16-18 hex nut. There are four holes in the frame and three holes in the arm to provide a total of 12 twelve possible mounting positions.
- 2.4.4.2 The guide head may be adjusted freely through 60° degrees for applications that require precise alignment.
- 2.4.4.3 Attach the guide head to the end of the guide arm using the provided hardware.
- 2.4.5 Cable can be released for maintenance by removing the rollers on the Guide Head without disconnecting the cable.

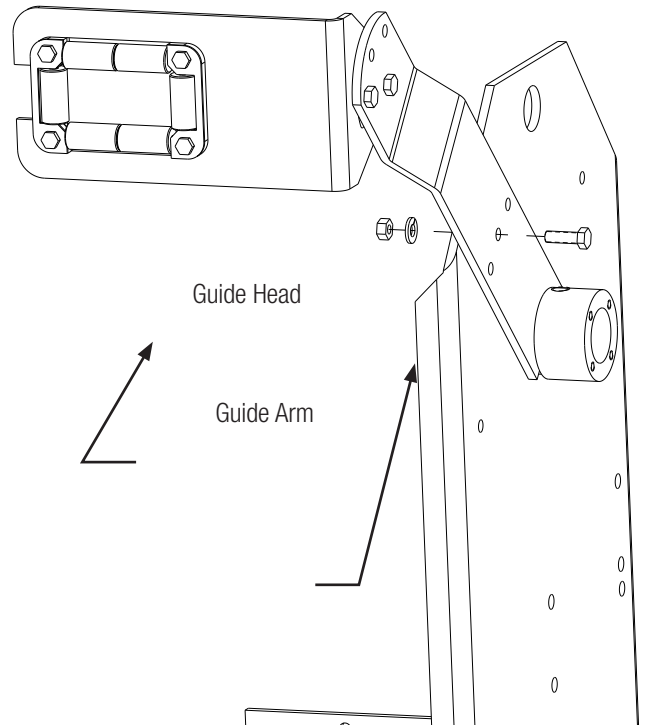

2.5 Ratchet

- 2.5.1 The ratchet option allows the extended cable to be pulled out and held from retraction by spring tension; generally appropriate for operator attended applications.
- 2.5.2 The ratchet for the 2500 Series Cable Reels is spring loaded. It is designed to function in all acceptable mounting configurations.
- 2.5.3 The ratchet option can be installed at the time of purchase or later added to reels that have already been introduced to service.

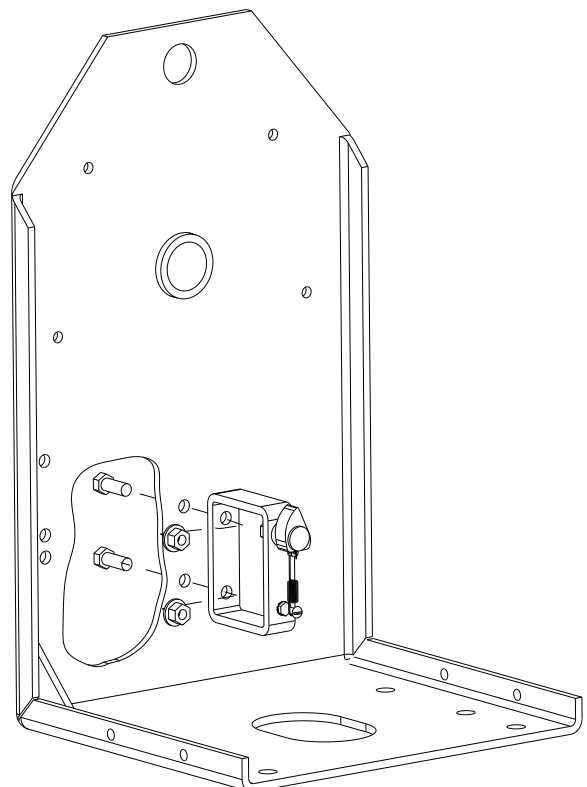

2.0 Installation

2.5.4 Ratchet Option Installation

2.5.4.1 **WARNING:** Power should be disconnected from the reel before beginning any service or maintenance functions. Follow lock-out/tag-out procedures appropriate to the installation.

2.5.4.2 Ratchet Pawl Installation

2.5.4.2.1 The ratchet pawl assembly is attached to the reel frame as a unit. The holes provided for the attachment of The ratchet pawl assembly are located in the lower middle area of the frame.

2.5.4.2.2 Insert the two (2) provided 3/8-16x1" bolts in the frame.

2.5.4.2.3 Position the ratchet pawl assembly over the protruding bolt shafts.

2.5.4.2.4 Secure using the two (2) provided sets of 3/8-16 hex nuts & lockwashers.

2.5.4.3 Ratchet Plate Installation

2.5.4.3.1 The cable must be extended far enough to allow the removal of the two spring-side flange bolts that are aligned with the cable entrance. (See item A below).

2.5.4.3.2 Substitute the provided longer flange bolts and nuts for the removed bolts and nuts.

2.5.4.3.3 Position the ratchet plate over the bolts on the outside of the spring-side flange. When viewed from the frame, the square tooth of the ratchet plate should be to the left-hand side.

2.5.4.3.4 Secure the ratchet plate to the spool by tightening the nuts to approximately 7 (seven) ft-lbs.

2.5.4.3.5 Additional ratchet plates may be installed but will increase the likelihood of spool lock-up at full cable extension.

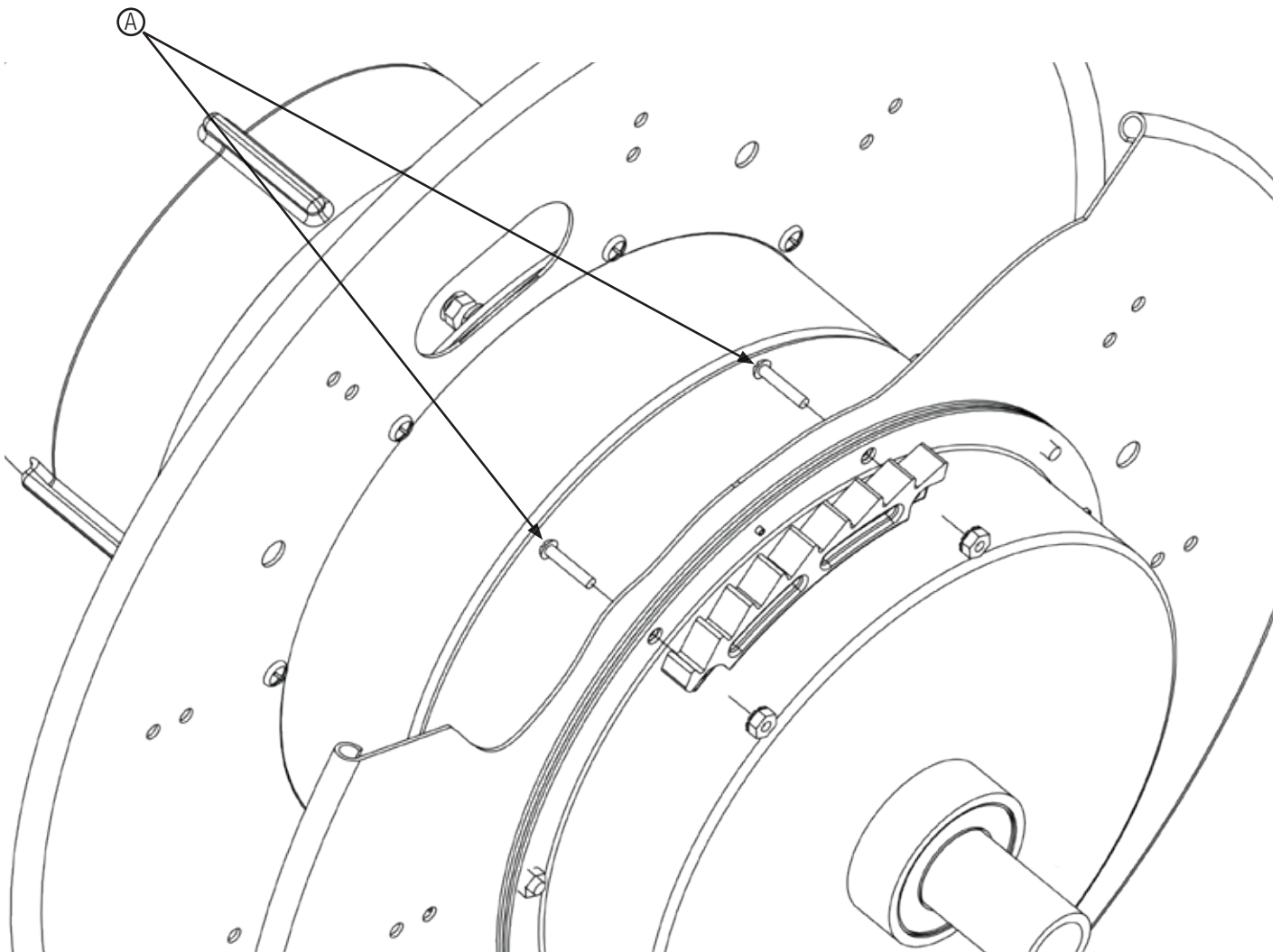

2.0 Installation

2.6 Spool Lock

2.6.1 All 2500 Series Cable Reels can be equipped with an optional Spool Lock.

2.6.2 The Spool Lock allows the power spring tension to be locked out from the cable spool. Applications that often require cable replacement would benefit from the addition of the Spool Lock.

2.6.3 The spring-loaded design of the Spool Lock maintains engagement under conditions of shock & vibration. This is good for applications which require the cable to remain extended and are subject to severe service conditions.

2.6.4 Spool Lock Installation

2.6.4.1 Attach the spool lock riser with (1) 3/8 x 3/4 bolt finger tight.

2.6.4.2 Insert the lock into the hole in the frame and the first riser hole. Place the spring on the lock shaft before it goes through the second riser hole.

2.6.4.3 Hold the spring back and insert a roll pin to keep the spring in position. Use the provided insert tool to center the roll pin through the shaft.

2.6.4.4 Tighten the mounting bolt.

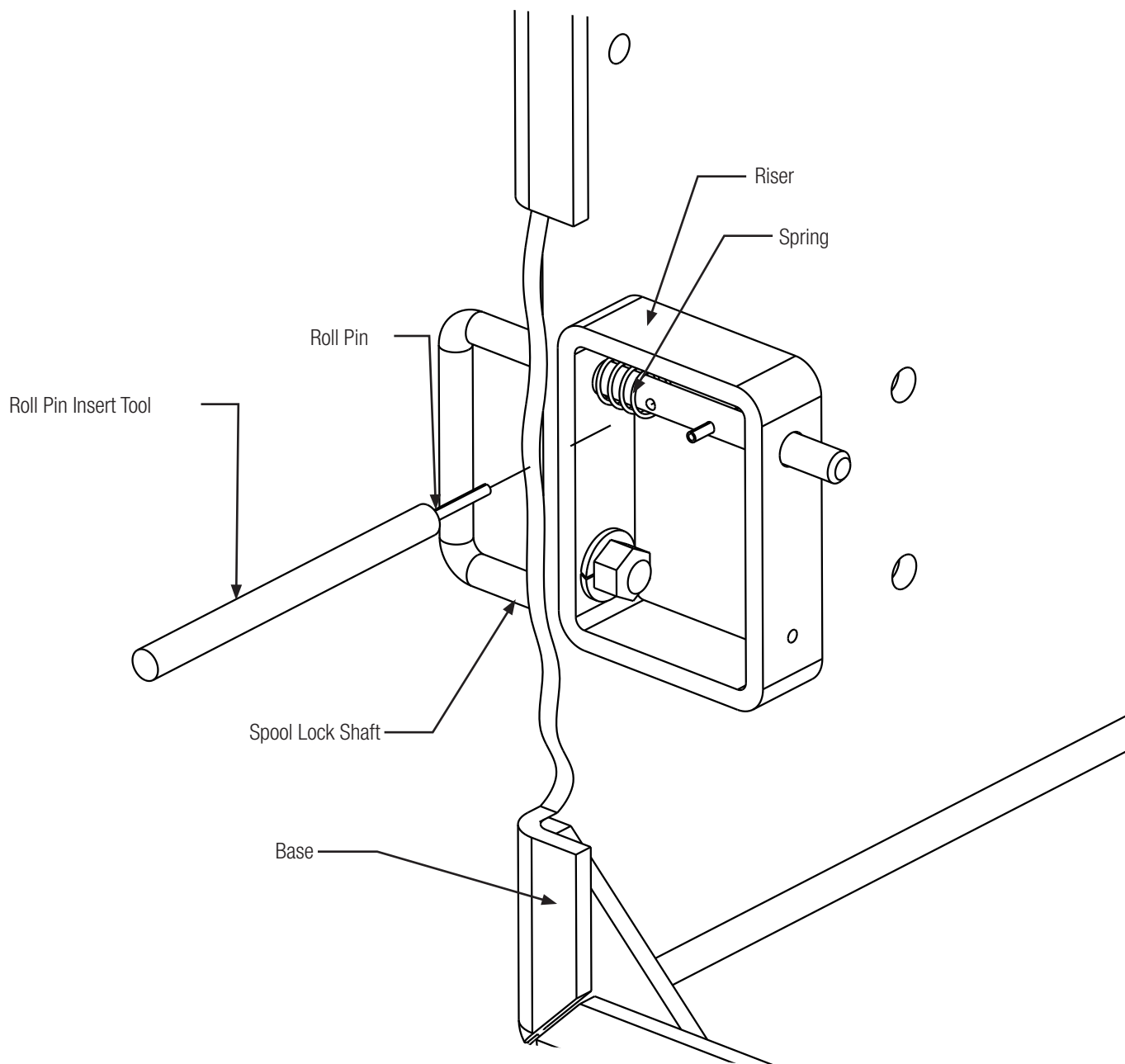

2.0 Installation

2.7 Spring Tension Adjustment

2.7.1 Spring Tension Warnings

2.7.1.1 More demanding applications may require spring tension adjustments for proper cable retraction.

2.7.1.2 **WARNING:** Do not allow cable to retract without restraining the retraction speed. Walk the cable back to the reel. The retraction speed should not exceed 150 ft/min. (approximately 1.7 mi/hr.).

2.7.2 Spring Cycling

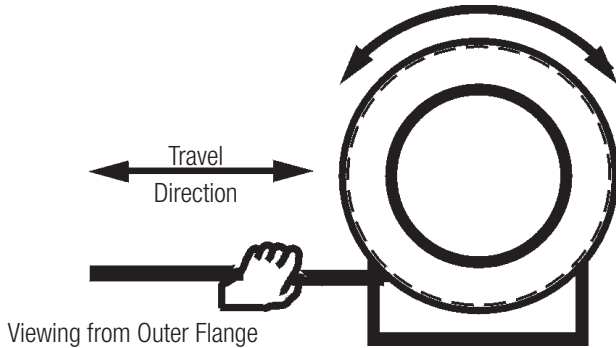

2.7.2.1 The spring should be cycled after mounting but before terminating the free end to assure that the cable will retract properly and operate under the correct tension.

2.7.2.2 This is accomplished by pulling the cable out the required distance and allowing it to rewind. This procedure should be performed five to ten (5-10) times.

2.7.3 Spring Pre-Tensioning



2.7.3.1 The proper pre-tensioning required for effective operation varies by cable diameter and cable weight. Trial and error is the most effective means of setting the proper spring pre-tension. Pre-tensioning is achieved by pre-loading the spring with setup turns (reel revolutions).

2.7.3.2 Relieve the spring of all tension before putting on setup turns. Grasp the end of the cable and the spool and rotate both spool and cable together in the payout direction until the spring engages.

2.7.3.3 Single Spring Motors (L, E, F) and Parallel Spring Motors (LP, EP, FP) require two setup turns. Series Spring Motors (LS, ES, FS) require four (4) setup turns.

2.7.3.4 Next, feed the end of the cable through the roller guide (if present) and test the Spring Tension. Pull the cable out the required distance and allow it to rewind.

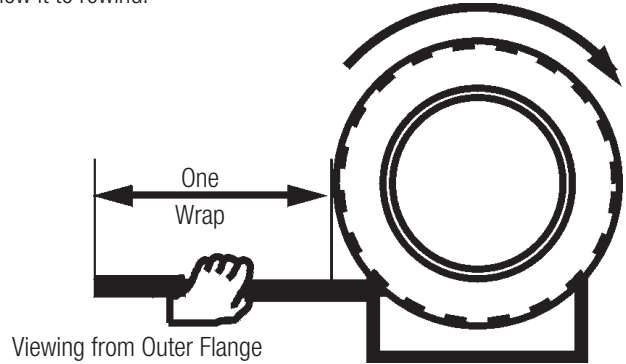

2.7.4 Adjusting Spring Tension

2.7.4.1 One additional setup turn may be added to provide increased tension if the total number of spool revolutions required to fully retract the cable plus the setup turns is less than the maximum number listed in the table below. One (1) setup turn can be removed if the torque is too high.

2.7.4.2 Do not add or remove setup turns on the reel after the cable has been terminated. The resulting twist may kink the cable and shorten cable life.

2.7.4.3 Secure the end of the cable using the appropriate terminals.

MAXIMUM SPRING TURNS	
Spring Motor	# Turns
E, EP, F, FP	15
L, LP	22
ES, FS	30
LS	44

Conductix also provides reels with left hand rotation. These reels payout in the opposite direction of standard reels and must be pre-tensioned the opposite direction as described above.

3.0 Operation

- 3.1 Do not exceed the voltage or ampere rating of the cable. Do not exceed the voltage or ampere rating of the reel. Overheating, fire, damage to equipment or personal injury could result. Do not allow cable to retract without restraining the retraction speed.
- 3.2 Operate the reel within the cable size and length and spring tensioning limits for which it was intended.
 - 3.2.1 Two wraps of cable should remain on the reel at maximum extension to avoid excessive tension on the cable entrance watertight and slip ring terminations.
 - 3.2.2 The spring should not be wound to the last two turns at maximum payout. This prevents over-stressing the spring(s), thus reducing its life or damaging the reel.
- 3.3 Keep the reel and cable clean to avoid excessive wear and damage.
- 3.4 Arrange for maintenance service if damage is found on the cable or reel.
- 3.5 To maximize spring life, cable should be fully retracted when not in use.

4.0 Maintenance

4.1 Maintenance Warnings

- 4.1.1 Be sure the power is off for maintenance.
- 4.1.2 Follow lock-out/tag-out procedures as outlined in OSHA Section 1910.147.

4.2 Lubrication

- 4.2.1 All springs and bearings are lubricated for life at the factory. Additional lubrication should not be required.
- 4.2.2 Do not apply any lubricants or solvent cleaning agents to the slip ring, brush, or insulator surfaces.

4.3 Inspections

- 4.3.1 Periodically check the reel for any loose or missing fasteners. Tighten or replace as necessary.

- 4.3.2 The slip ring assembly should be checked periodically as follows:

- 4.3.2.1 Clean to remove any accumulated dust or dirt from the slip ring housing area.
- 4.3.2.2 Check all brush and ring surfaces in the slip ring assembly and remove any accumulated dust.
- 4.3.2.3 Brushes should be centered on the slip rings and brush springs should be seated in the slot on top of the brush. Terminal screw connections should be tight.

- 4.3.2.4 Replace Brushes when the brush spring is within 0.09" of the ring insulator.

- 4.3.3 Inspect cable for damage or wear which would make it unsafe to use.

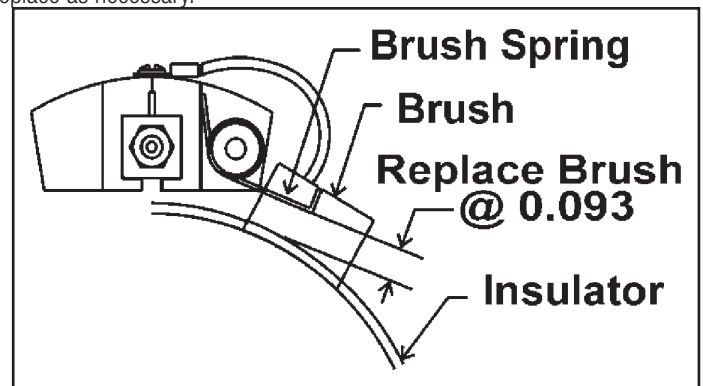

5.0 Replacement Parts

5.1 R-Series Slip Rings for 2500 Series

To identify the slip ring in 2500 Series reels for replacement parts, it is necessary to precede the amperage profile section with the product code "RA-". This code specifies that the Slip Ring is a member of the R-Series Slip Ring family and designates the bore size as 1-1/2 inches.

‡ Multiple Amperage Sections are possible.

* Consult the factory for Custom Application Part Numbers

§ Available for Special Applications

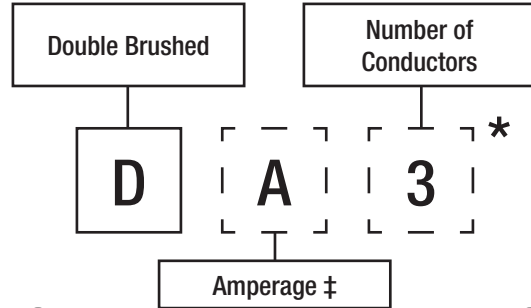

Brushes	Amperage ‡		Brush Holders	
	Single	Double	Single	Double
30068A	D	= 35 AMP / 600 V	02801	02808
30069A	E	= 75 AMP / 600 V	02802	02809
02840	F	= 110 AMP / 600 V	02803	02810
02841	G	= 150 AMP / 600 V	02804	02811
02842	H	= 225 AMP / 600 V	02805	02805
02843	J	= 300 AMP / 600 V	02806	02806

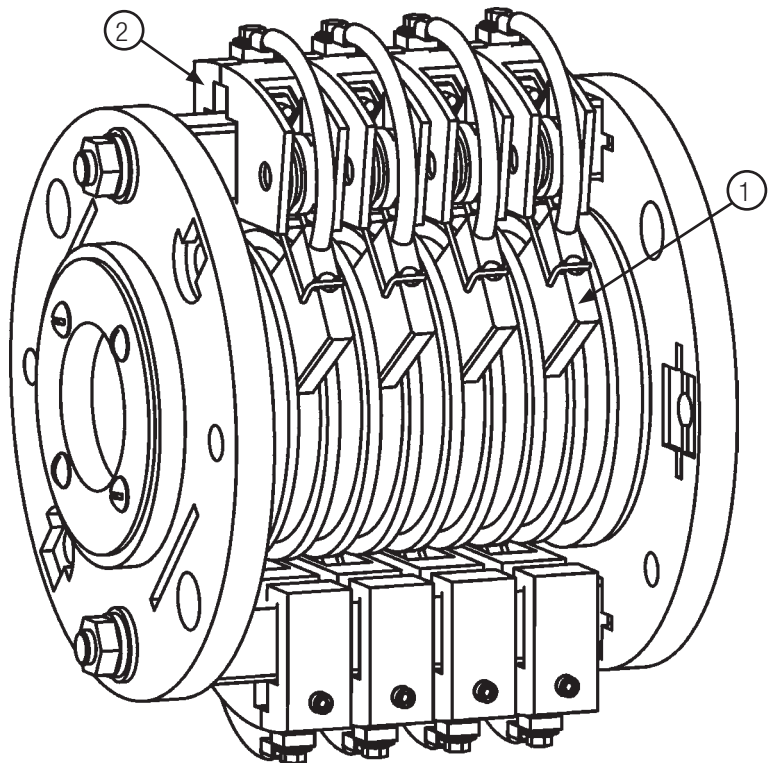
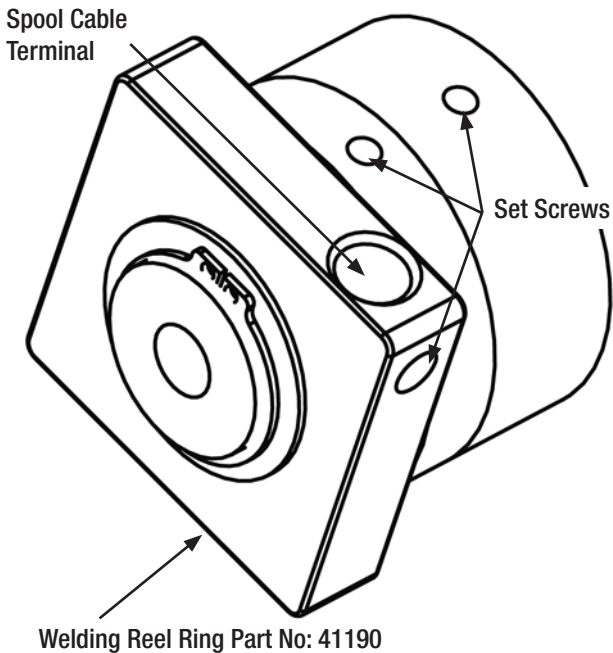

5.0 Replacement Parts

5.2 Reel Part Descriptions

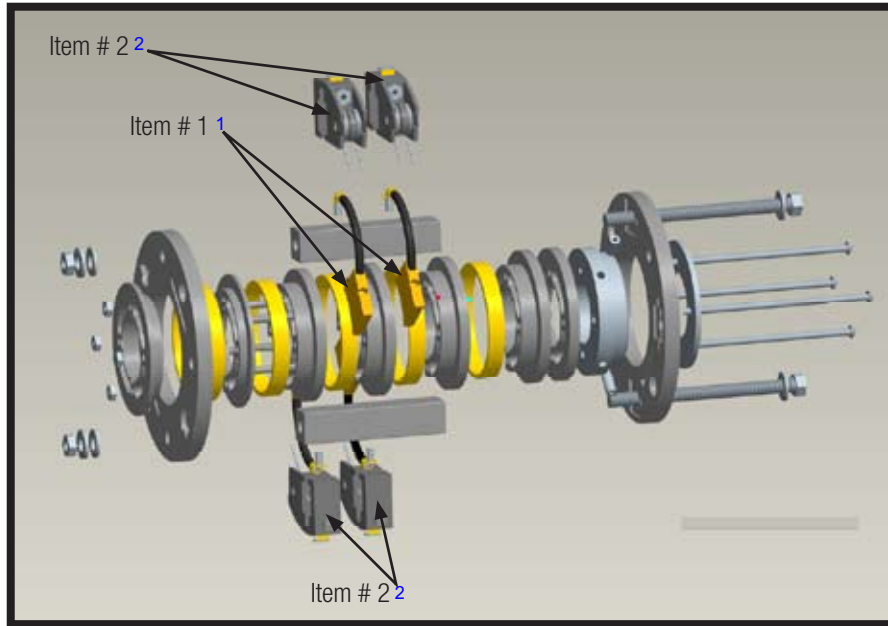

Item # 1 Replacement Brushes		
AMPERAGE	Part Number	
15 AMP Silver Plated	30067A	
15 AMP	30066A	
35 AMP	30068A	
75 AMP	30069A	
110 AMP	02840	
150 AMP	02841	
Item # 2 Replacement Brush Holder		
AMPERAGE	Part Number	Double Brushed Holder
15 AMP Silver Plated	Always Double Brushed	02807
15 AMP	02800	02807
35 AMP	02801	02808
75 AMP	02802	02809
110 AMP	02803	02810
150 AMP	02804	02811

5.0 Replacement Parts

5.2 Reel Part Descriptions

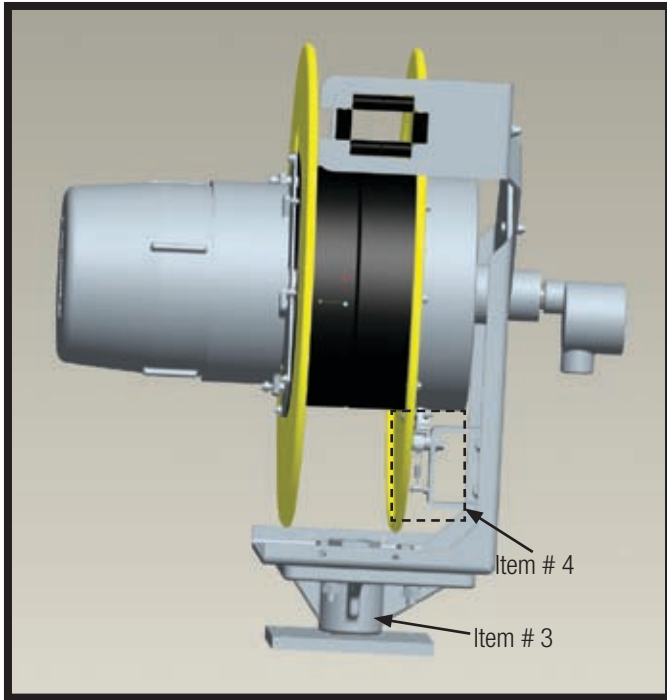

1

Item # 3 Pivot Base	
Pivot Base (330 Degree)	40274X

2

Item # 4 Ratchet Kit	
Ratchet Kit	Spring Size
40251A-K	E&L
4021B-K	F

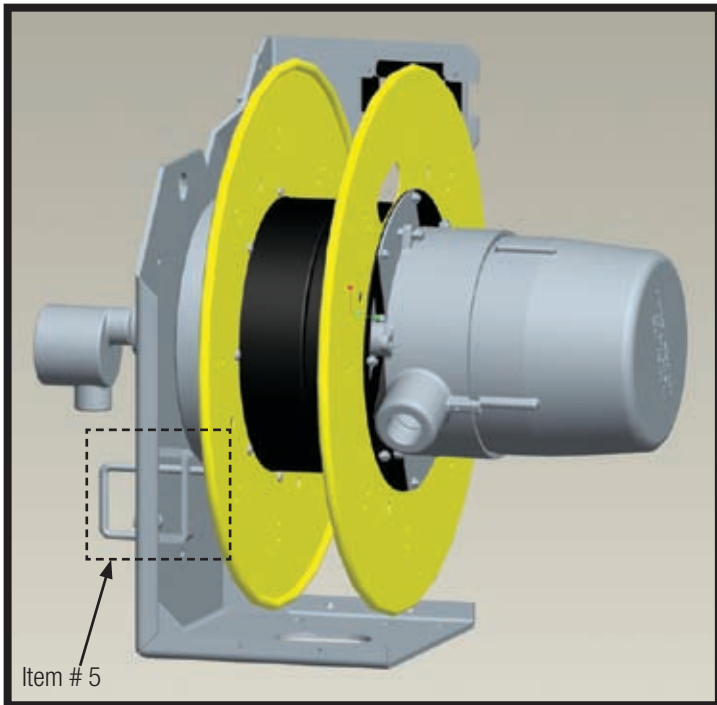

3

Item # 5 Spool Lock Kit	
Spool Lock	Spring Size
40260A-KX	E&L
40260B-KX	F

6.0 Troubleshooting

PROBLEM	POSSIBLE CAUSE	SOLUTION
Reel will not retract cable but has some tension.	<ol style="list-style-type: none"> 1) Improper pretension 2) Incorrect reel for application (lift vs. stretch). 3) Improper cable or cable length installed. 	<ol style="list-style-type: none"> 1) See Tension Adjustment section. 2) Quantify application vs. reel selection. 3) Consult factory.
Reel does not have spring tension.	<ol style="list-style-type: none"> 1) Broken spring. *Quantify application to prevent reoccurrence. 	<ol style="list-style-type: none"> 1) Consult factory.
Ratchet will not engage.	<ol style="list-style-type: none"> 1) Broken ratchet pawl spring. 	<ol style="list-style-type: none"> 1) Replace ratchet pawl spring.
Ratchet will not disengage.	<ol style="list-style-type: none"> 1) Over-extension of reel. 	<ol style="list-style-type: none"> 1) Manually rotate reel spool to disengage ratchet. To prevent lockup, two wraps of cable should remain on spool at all times.
Cable wraps improperly (uneven wrapping, wraps above or jumps flange).	<ol style="list-style-type: none"> 1) Reel mounting not level. 2) Cable retraction rate too high. 3) Cable guide out of adjustment. 	<ol style="list-style-type: none"> 1) Mount reel on level surface. 2) Maintain steady retraction rate. 3) Properly adjust cable guide.
Cable twisting or knotting.	<ol style="list-style-type: none"> 1) Improperly installed cable. 2) Cable rubbing on or bending around fixed object. 3) Excessive spring tension. 4) Inadequate anchoring of cable. 	<ol style="list-style-type: none"> 1) Check roller guide for function and cable pay out path. 2) Quantify application vs. reel selection. Also check pretension. 3) Adjust anchoring method. ie. add strain relief.
Open or intermittent circuit.	<ol style="list-style-type: none"> 1) Inadequate connection. 2) Brush loses contact with slip ring. 3) Cable defective. 	<ol style="list-style-type: none"> 1) Check all termination points. 2) Check brush wear, spring tension & alignment. 3) Perform continuity check on cable.
Circuit trips and/or Pitted burned rings or brushes.	<ol style="list-style-type: none"> 1) Inadequate amp rating of reel. 	<ol style="list-style-type: none"> 1) Quantify application requirements vs. reel & cable rating.
Circuit arcing	<ol style="list-style-type: none"> 1) Amp or voltage above rating of reel. 2) Excessive carbon dust accumulation. 3) Water or moisture in slip ring. 	<ol style="list-style-type: none"> 1) Quantify application requirements vs. reel & cable rating. 2) Clean dust from inside slip ring. 3) Check gasket seal. 4) Replace brush spring.

Notes

Notes

www.conductix.com

Conductix-Wampfler

10102 F Street
Omaha, NE 68127
USA

Customer Support
Phone: 800 521 4888
Fax: 800 780 8329

Phone: 402 339 9300
Fax: 402 339 9627

info.us@conductix.com
www.conductix.com

