

# Cable Reels

## Series 1400

(Including 1400 Series Welding and Grounding Reels)

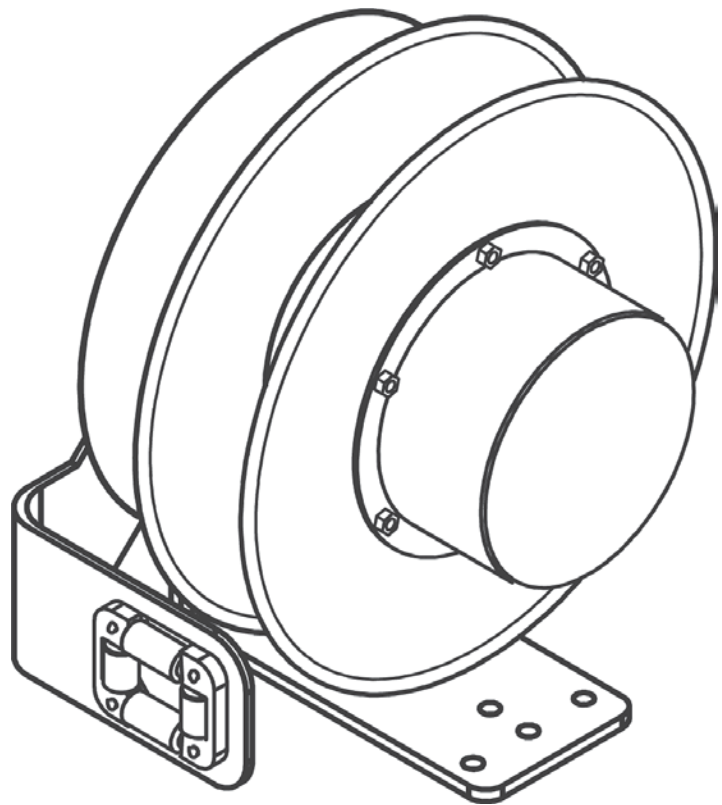

# Conductix Incorporated

The technical data and images which appear in this manual are for informational purposes only. **NO WARRANTIES, EXPRESS OR IMPLIED, INCLUDING WARRANTIES OF MERCHANTABILITY OR FITNESS FOR A PARTICULAR PURPOSE, ARE CREATED BY THE DESCRIPTIONS AND DEPICTIONS OF THE PRODUCTS SHOWN IN THIS MANUAL.** Conductix makes no warranty (and assumes no liability) as to function of equipment or operation of systems built according to customer design or of the ability of any of its products to interface, operate or function with any portions of customer systems not provided by Conductix.

Seller agrees to repair or exchange the goods sold hereunder necessitated by reason of defective workmanship and material discovered and reported to Seller within one year after shipment of such goods to Buyer.

Except where the nature of the defect is such that it is appropriate, in Seller's judgment, to effect repairs on site, Seller's obligation hereunder to remedy defects shall be limited to repairing or replacing (at Seller's option) FOB point of original shipment by Seller, any part returned to Seller at the risk and cost of Buyer. Defective parts replaced by Seller shall become the property of Seller.

Seller shall only be obligated to make such repair or replacement if the goods have been used by Buyer only in service recommended by Seller and altered only as authorized by Seller. Seller is not responsible for defects which arise from improper installation, neglect, or improper use or from normal wear and tear.

Additionally, Seller's obligation shall be limited by the manufacturer's warranty (and is not further warranted by Seller) for all parts procured from others according to published data, specifications or performance information not designed by or for Seller.

Seller further agrees to replace or at Seller's option to provide a refund of the sales price of any goods that do not conform to applicable specifications or which differ from that agreed to be supplied which non-conformity is discovered and forthwith reported to Seller within thirty (30) days after shipment to the Buyer. Seller's obligation to replace or refund the purchase price for non-conforming goods shall arise once Buyer returns such goods FOB point of original shipment by Seller at the risk and cost of Buyer. Goods replaced by Seller shall become the property of Seller.

There is no guarantee or warranty as to anything made or sold by Seller, or any services performed, except as to title and freedom from encumbrances and, except as herein expressly stated and particularly, and without limiting the foregoing, **there is no guarantee or warranty, express or implied, of merchantability or of fitness for any particular purpose or against claim of infringement or the like.**

Seller makes no warranty (and assumes no liability) as to function of equipment or operation of systems built to Buyer's design or of the ability of any goods to interface, operate or function with any portions of Buyer's system not provided by Seller.

Seller's liability on any claim, whether in contract, tort (including negligence), or otherwise, for any loss or damage arising out of, connected with, or resulting from the manufacture, sale, delivery, resale, repair, replacement or use of any products or services shall in no case exceed the price paid for the product or services or any part thereof which give rise to the claim. In no event shall Seller be liable for consequential, special, incidental or other damages, nor shall Seller be liable in respect of personal injury or damage to property not the subject matter hereof unless attributable to gross misconduct of Seller, which shall mean an act or omission by Seller demonstrating reckless disregard of the foreseeable consequences thereof.

Seller is not responsible for incorrect choice of models or where products are used in excess of their rated and recommended capacities and design functions or under abnormal conditions. Seller assumes no liability for loss of time, damage or injuries to property or persons resulting from the use of Seller's products. Buyer shall hold Seller harmless from all liability, claims, suits and expenses in connection with loss or damage resulting from operation of products or utilization of services, respectively, of Seller and shall defend any suit or action which might arise there from in Buyer's name - provided that Seller shall have the right to elect to defend any such suit or action for the account of Buyer. The foregoing shall be the exclusive remedies of the Buyer and all persons and entitles claiming through the Buyer.

## 1.0 Safety Instructions

- 1.1 Electrical Warnings
- 1.2 Operational Warnings
- 1.3 Maintenance Warnings
- 1.4 UL/cUL Rating
- 1.5 Electrical Rating
- 1.6 Labels and Marking

## 2.0 Installation

- 2.1 Application Types
- 2.2 Mounting (w/ or w/o Pivot Base)
- 2.3 Roller Guide (w/ or w/o Flop Over Option)
- 2.4 Ratchet
- 2.5 Cable Installation
- 2.6 Spring Tension Adjustment
- 2.7 Power Connections

## 3.0 Operation

## 4.0 Maintenance

- 4.1 Maintenance Warnings
- 4.2 Lubrication
- 4.3 Inspections
- 4.4 Slip Ring and Feeder Cord Replacement
- 4.5 Cable Replacement
- 4.6 Spring Motor Replacement

## 5.0 Troubleshooting

## 6.0 Replacement Parts

- 6.1 Exploded View
- 6.2 Parts Numbers and Order Form

### RECORD

The catalog number of the reel and the serial number of the reel are required when ordering replacement parts or discussing the reel with the factory. Please record this information now in the spaces provided below.

CATALOG NO. OF REEL \_\_\_\_\_

SERIAL NO. \_\_\_\_\_

DATE INSTALLED \_\_\_\_\_

## 1.1 Electrical Warnings

1.1.1 Properly ground equipment before use in accordance with both the National Electric Code and local electrical codes and ordinances.

1.1.2 Disconnect electrical power from the cable reel before performing any service functions.

1.1.3 Do not use cable reel for loads greater than the current rating listed on the label and voltage greater than 600V. The ampacity (current) rating of the cable must be in accordance with the National Electric Code.

1.1.4 Electrical wiring on the reel must be done by a qualified electrician.

## 1.2 Operational Warnings

1.2.1 Exercise care when handling the cable reel during normal operation. This cable reel has a rotating spool powered by springs under tension.

1.2.2 Do not allow the cable to retract without restraining the retraction speed.

1.2.3 Do not disassemble the spring motor for any reason. Serious personal injury could result. This cable reel is equipped with springs under tension. Contact the factory for assistance:

In the US call: 1-800-521-4888 In Canada call: 1-800-667-2487

## 1.3 Maintenance Warnings

1.3.1 Do not use cable different from that for which the reel is intended. Changes in diameter, weight per foot, length of cable or flexibility will affect the operation of the reel.

1.3.2 Mounting hardware and fasteners should be installed to maintain tightness under vibration and checked periodically to assure tightness.

1.3.3 Overhead installation mountings should be such that the reel is not suspended by bolts in tension. A safety chain or cable is strongly recommended to minimize damage and/or possible injury in the event of mounting failure.

1.3.4 **WARNING:** Modification of this equipment may cause excessive wear and will void the warranty. Contact the manufacturer regarding changes or modifications of equipment which could affect reliability or safety.

## 1.4 UL/cUL Ratings



**LISTED  
REEL  
6 7 N 6**



1.4.1 Reels that are Listed UL/cUL Nema 4X are indicated in the catalog.

1.4.2 The two requirements that follow apply for UL/cUL listed POWEREEL products:

1.4.2.1 Listed cable reels are intended for commercial/industrial use and are provided with permanent mounting means.

They must be wired by a qualified electrician. These cable reels are not provided with a Feeder Cable and connector.

1.4.2.2 UL listed type SOW-A or SOOW-A, 600V, rated 90°C or 105°C must be used for the supply cable (if flexible cable is used) and for the load end cable (active cable).

Serial #		Cat #		Made in U.S.A.	
Volts	Amps	Watts	PSI	NEMA	
Cable / Hose					

# 1.0 Safety

## 1.5 Electrical Ratings

### 1.5.1 Reels Equipped with or without Cable

1.5.1.1 All 1400 Series reels with or without cable are rated and should not be used at voltages and or amperes above the rating on the reel.

Please consult the factory prior to making any changes in volts and amps of cable, as change could affect reliability or safety

(See Section 1.3.4 and 1.6.4)

SOW-A (90°C) or SOOW-A (105°C)			
Cable AWG / # of Cond.	Ampacity	Cable AWG / # of Cond.	Ampacity
16/2	10.0	12/2	20.0
16/3	10.0	12/3	20.0
16/4	8.0	12/4	16.0
16/5	8.0	12/5	16.0
16/6	7.0	12/6	16.0
16/7	7.0	12/7	14.0
16/8	5.0	12/8	14.0
16/10	5.0	10/2	25.0
16/12	5.0	10/3	25.0
14/2	15.0	10/4	20.0
14/3	15.0	10/5	20.0
14/4	12.0	10/6	20.0
14/5	12.0	6/1	95
14/6	12.0	4/1	150
14/7	10.5	2/1	200
14/8	10.5	1/1	250
14/10	7.5	1/0/1	350

**Table 1**

## 1.6 Labels & Markings



**LISTED  
REEL  
6 7 N 6**



1.6.1 Every cable reel is marked with a label on the base which includes the Conductix-Wampfler name and logo, the product catalog number and the individual product serial number, NEMA rating, Amps, Volts, Watts and Cable Footage.

1.6.2 The UL / cUL Listing Mark is applied to reels that comply with the applicable requirements and are identified with the authorizing mark.

1.6.3 The maximum cable footage, amperage and voltage rating for every cable reel supplied without cable is marked on the Conductix Identification Label. The actual cable installed should not differ from what is indicated on the Conductix-Wampfler label. If the cable must be different please consult the factory prior to installing the cable to ensure the change will not affect the reliability of the reel or the safety of the people working with the reel.

## 2.0 Installation

### 2.1 Application Types

#### 2.1.1 Stretch Applications



2.1.1.1 The cable is suspended without any intermediate support. Stretch reels generally require a line pull equal to two times the weight of the cable, which allows approximately 10% sag at full extension. On long applications where sag cannot be tolerated, it is sometimes desirable to put supports at intervals of 5 to 10 feet.



#### 2.1.2 Lift Applications

2.1.2.1 The cable is lifted vertically in lift applications. The reel is normally designed to handle only the total weight of the cable. Some lift applications may require ball stops to control the length of cable to be retracted.

#### 2.1.3 Drag Applications

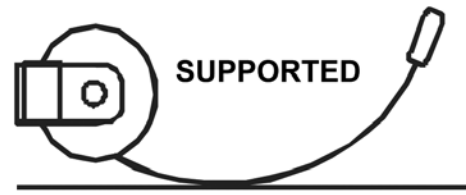

2.1.3.1 The reel is mounted on a stationary object and is required to drag the cable over the surface to the reel. The cable is supported by the ground or some type of cable tray. A ball stop may be required.

#### 2.1.4 Retrieve Applications

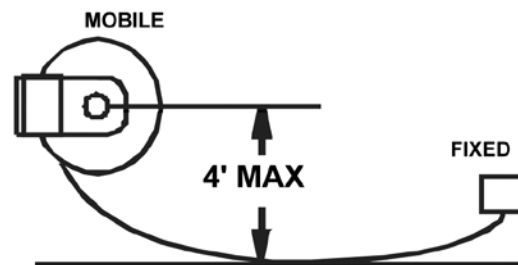

2.1.4.1 The reel is Mounted on the moving object and winds up or pays out the cable as the machine approaches or moves away from the fixed end. Retrieve applications can be elevated up to 4 feet from the cable support surface.

### 2.2 Mounting

#### 2.2.1 Standard Mounting

2.2.1.1 The reel may be mounted by bolting the base to any flat surface which is structurally sound enough to support it and the forces of winding and unwinding the cable.

2.2.1.2 The spool drum must rotate on a level horizontal axis.

2.2.1.3 Position the guide arm so that cable payout is perpendicular to the face of cable roller guide. The total cable deflection should not exceed  $15^\circ$  to either side of the center line of the spool.

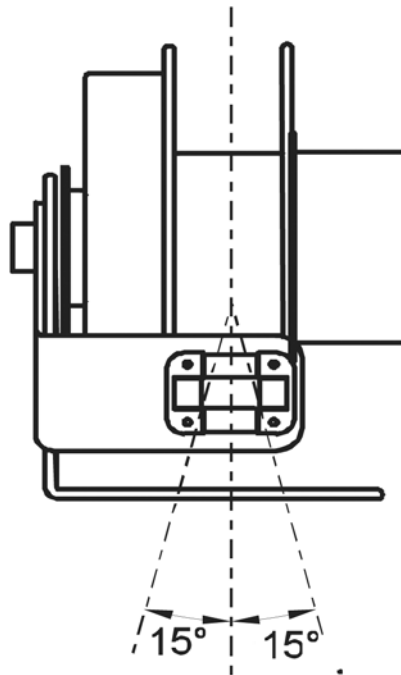

Fig. 2.2 Cable Deflection with Roller

2.2.1.4 If deflection is constant to either side of the reel and operation is impaired re-mount the reel.

2.2.1.5 If the angle of deflection exceeds  $30^\circ$  a Pivot Base should be used, otherwise excessive cable wear and unreliable operation will result.

2.2.1.6 A safety chain or cable is recommended for all overhead installations. Attach the safety chain using the 0.39 hole provided in the base. (See figure 2.3 on Page 6)

## 2.0 Installation

### 2.2.2 Pivot Base Mounting

2.2.2.1 All 1400 Series Cable Reels can be furnished with a pivot base to allow the reel to rotate and keep the extended cable perpendicular to the application.

2.2.2.2 The PVB Pivot Base has the ability to rotate Up to 345°. Travel can be limited to 90°, 180°, or 270° by installing an additional roll pin in the appropriate available hole. This Pivot Base is not suitable for applications requiring continuous rotation.

2.2.2.3 A pivot base is required in carousel or loop-track applications.

2.2.2.4 When a pivot base is used, the reel must be mounted horizontally ("ceiling" or "floor" mounted).

2.2.2.5 The Roller Guide should be mounted so the cable will travel perpendicular to the axis of rotation. This will guard against the cable twisting and ensure effective swivel action from the pivot base.

2.2.2.6 Selection of mounting holes should be such that the spool center is in line with the center point of the pivot base. The description on the Conductix-Wampfler label will show if the reel is PA, PB, or PC

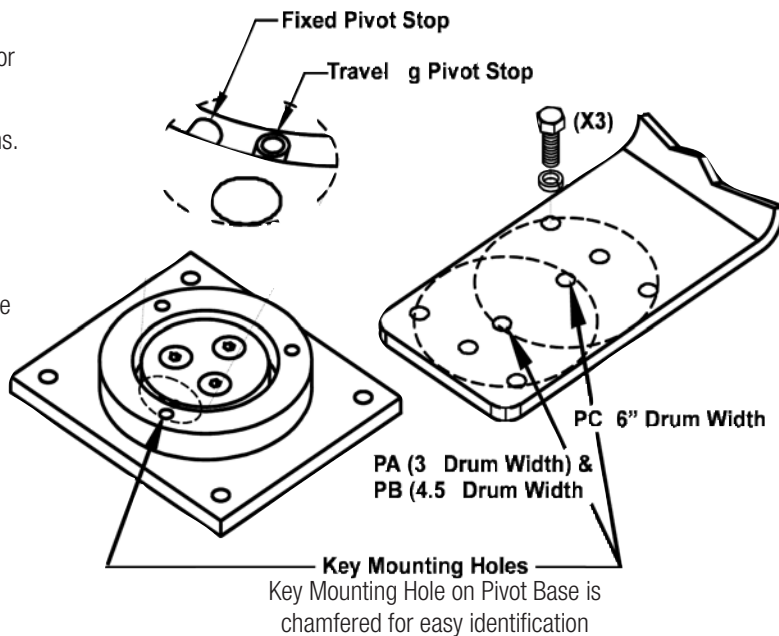

Fig.2.2.2

### 2.3 Roller Guide

2.3.1 All 1400 Series units are equipped with a roller guide (PR87-#). The function of the guide is to center the cable on the spool and to help the reel wrap cable more evenly.

2.3.2 The cable should not bear against either end of the spool during winding as this will tend to inhibit level winding of the cable.

2.3.3 The guide should be secured at the best of twelve possible positions so that a minimum change of direction occurs at the guide; otherwise, cable life will be reduced.

2.3.4 The guide is shipped installed on the reel. The guide must be aligned per application and secured prior to making any electrical connections.

2.3.4.1 Mount the roller guide to the reel over the entrance coupling on the frame. Secure using the provided 5/16-18 hex head cap screw, including the spring-type lock washer. Torque this screw to 15 ft-lbs.

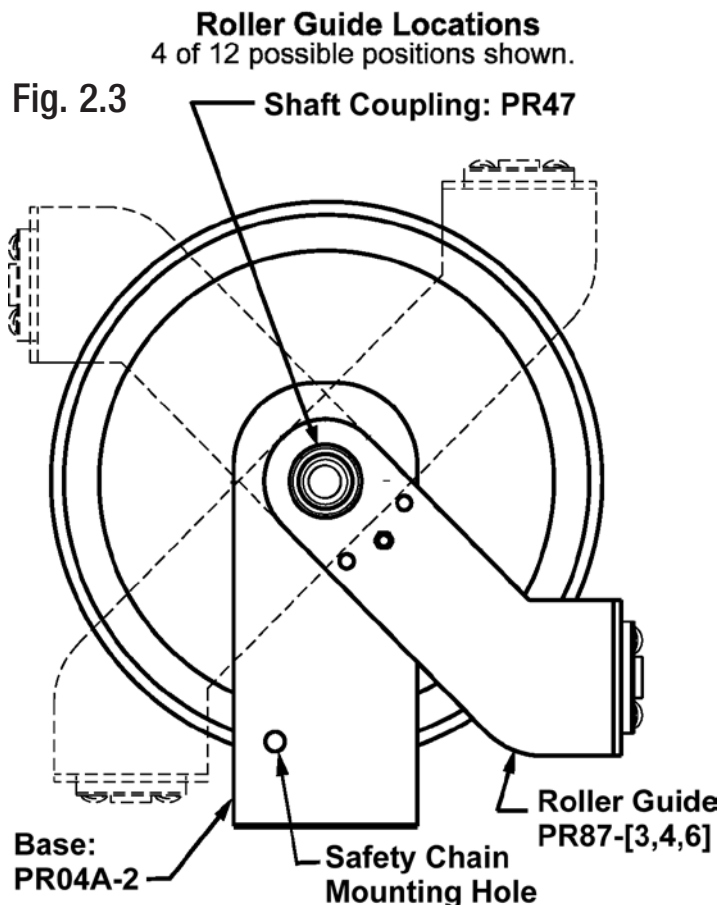

## 2.0 Installation

### 2.3.5 Flop-Over Guide Arm Kit (Part Number FGK)

(Numbers in paragraphs refer to Figure 2.3.5 and to Replacement Parts Order Form.)

2.3.5.1 Note: The Flop-Over Guide Arm Accessory Kit is appropriate for 2-way payout applications requiring a roller guide when a pivot base is not appropriate.

2.3.5.2 Before installing, be sure the power is off.

2.3.5.3 Disconnect the cable that provides power to the reel, if installed.

2.3.5.4 Remove the original shaft coupling (PR47) and replace with the grooved shaft coupling, Item 15. (PR47B)

2.3.5.5 Make sure the grooved side of the shaft coupling is nearest the base, Item 11.

2.3.5.6 Tighten the shaft coupling to 30-40 ft-lbs. torque.

2.3.5.7 Place one thrust washer, Item 16, (05453) on the shaft coupling and locate it flush against the base.

2.3.5.8 Position the guide arm, Item 8 (PR87-X), on the shaft coupling.

2.3.5.9 Slip the radial bearing strip, Item 17, (PR50D-1) between the shaft coupling and the guide arm. Trimming may be required.

2.3.5.10 Locate the second thrust washer, Item 16 (05453), on the shaft coupling.

2.3.5.11 Secure the assembly with the snap ring, Item 18 (5100-150).

2.3.5.12 Re-connect the supply cable.

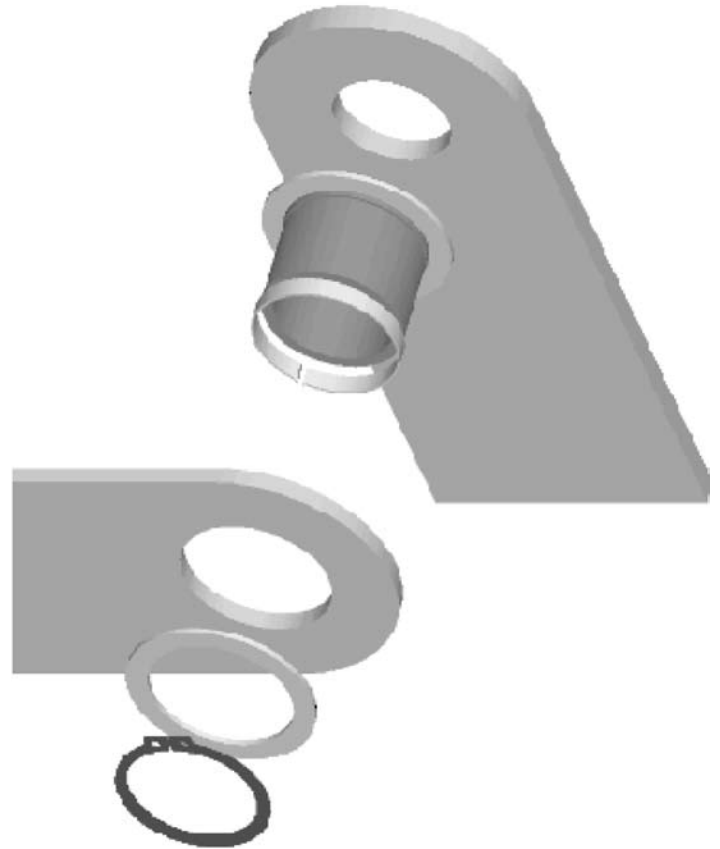

## 2.0 Installation

### 2.4 RATCHET

#### 2.4.1 Ratchet Lock

2.4.1.1 The ratchet lock can be engaged or disengaged, depending upon the application.

#### 2.4.2 Operation with Ratchet

2.4.2.1 The ratchet pawl is spring loaded. It is designed to function in all acceptable mounting configurations.

2.4.2.2 A slight pull on cable will disengage the ratchet.

#### 2.4.3 Operation without Ratchet

2.4.3.1 Disengage the ratchet by pivoting the lock-out bar to the lower position. This will remove the ratchet pawl from the path of the ratchet plate. Locate the dimple on the lock-out bar in the hole provided.

2.4.3.2 **WARNING:** Do not engage the ratchet abruptly. Sudden engagement may cause excessive shock loads to the ratchet pawl.

Fig. 2.4

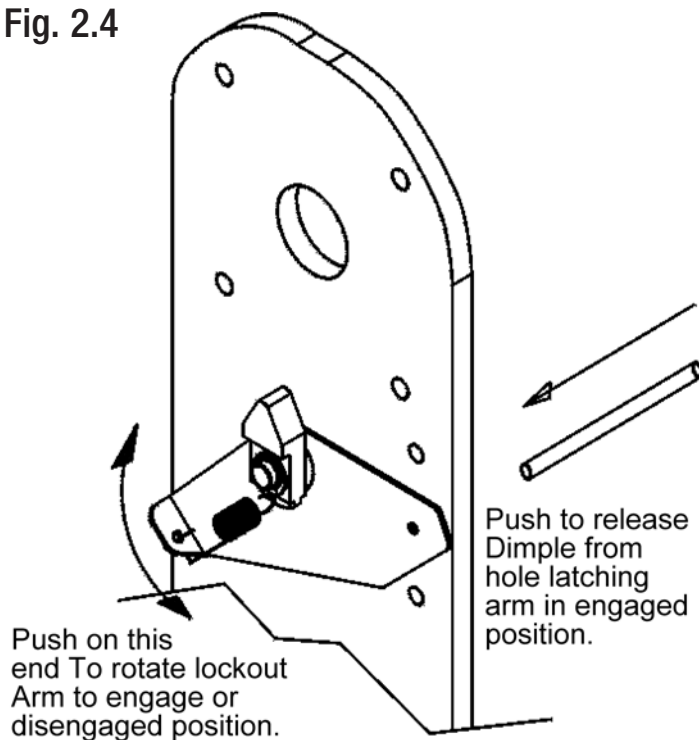

### 2.5 Cable Installation

2.5.1 Either of two methods for installing cable on the reel may be used. The first method is to simply lay the cable out straight along the path of travel and wrap onto the reel. The second method requires using a support for the cable being wrapped (see Figure 2, page 9). In either method, it is important that the cable not twist or loop.

2.5.2 Remove the (6) nuts securing the slip ring cover. Remove cover and gasket. Reinstall (2) nuts finger tight to hold the flange in place.

2.5.3 Loosen the set screw (1/8" Allen Wrench) at the base of the slip ring stack and remove the slip ring.

2.5.4 Strip the cable jacket back approximately 10" from end of cable and thread it through the cable entrance watertight into the drum of the reel. We recommend a cable-tie on 16 AWG, 2 and 3 conductor cable (see Figure 1 on page 9).

2.5.5 Install the rubber grommet, gripper ring, and the watertight nut. Tighten the nut to secure the cable.

2.5.6 Extend the conductors out of the drum. Reinstall the slip ring stack, being sure to engage the drive pin making sure point of set screw engages 1 of the 2 holes on the shaft and tighten the set screw. On 6" deep spool drums, we recommend connecting the 1-6 leads to the brush post terminal before installing the ring on the shaft. (See Sections 4.4 and 4.5)

2.5.7 Strip and insert cable leads into the appropriate brush post terminals and tighten screws. (See page 9 for Color Code Chart used by factory. Figure 3 illustrates Slip Rings, and Figure 3a illustrates Welding Rings.) All weld cable lead ends should be tinned for optimal performance (Fig. 3A)

2.5.8 **CAUTION:** The green conductor **MUST** be connected to (GND) Ring (ring closest to the brush post base) in order to ground the reel. Be sure that the bottom brush (dedicated ground) and the green wire at the top terminal block have continuity. (On Welding Reels, all conductor welding cable ends require tinning per NEC.)

2.5.9 Perform a continuity check to verify circuits.

2.5.10 Replace the cover gasket if damaged. Caution: Damaged gaskets affect UL rating of reel.

2.5.11 Remove (2) nuts. Install gasket and cover. Re-install and tighten nuts (6).

2.5.12 Wrap new cable on drum spool.

2.5.13 Adjust spring tension by following the procedure in Section 2.6.

## 2.0 Installation

COLOR CODE CHART					
Cond. No.	Base Color	Tracer Color	Cond. No.	Base Color	Tracer Color
1	Green	--	7	White	Black
2	Black	--	8	Red	Black
3	White	--	9	Green	Black
4	Red	--	10	Orange	Black
5	Orange	--	11	Blue	Black
6	Blue	--	12	Black	White

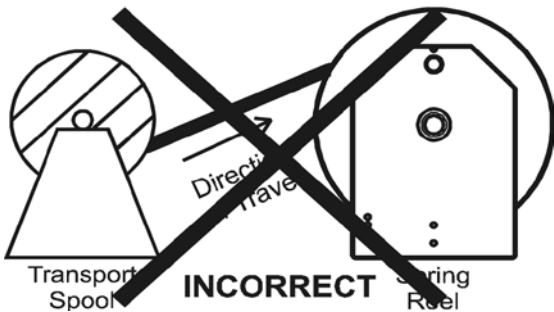
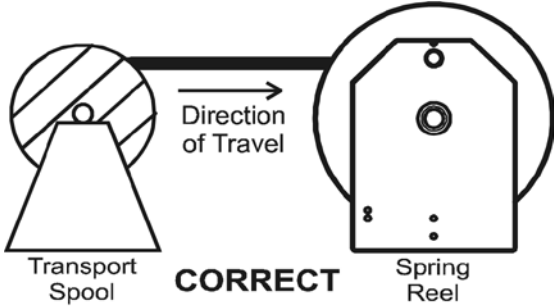

Figure 2

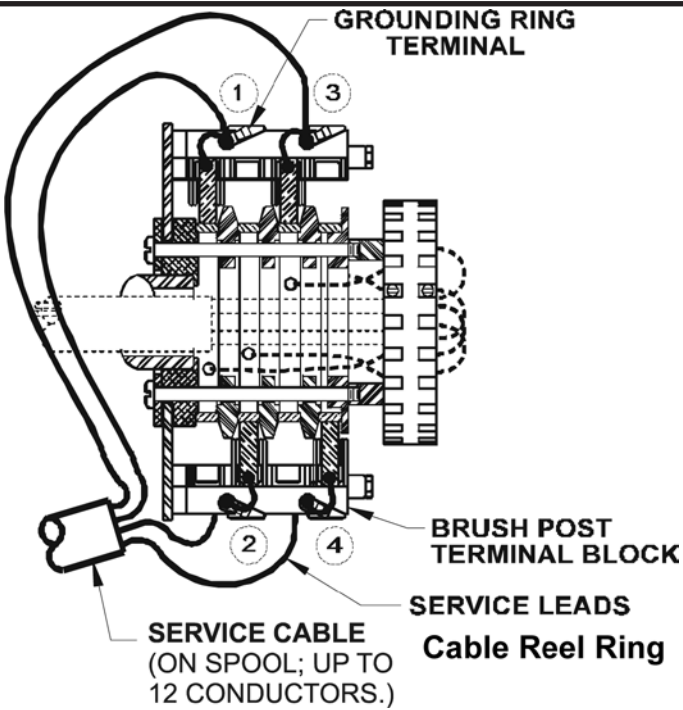

Figure 3

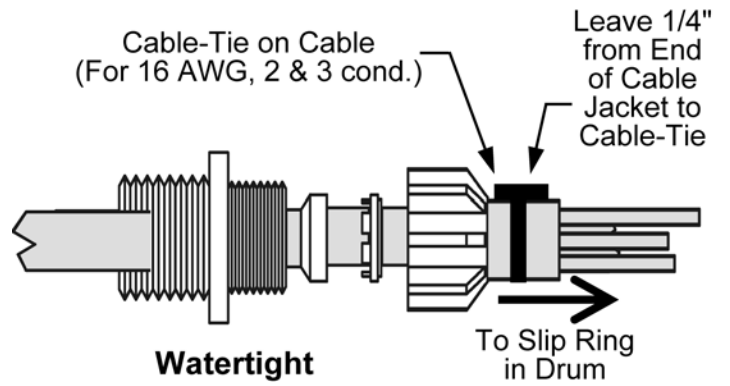
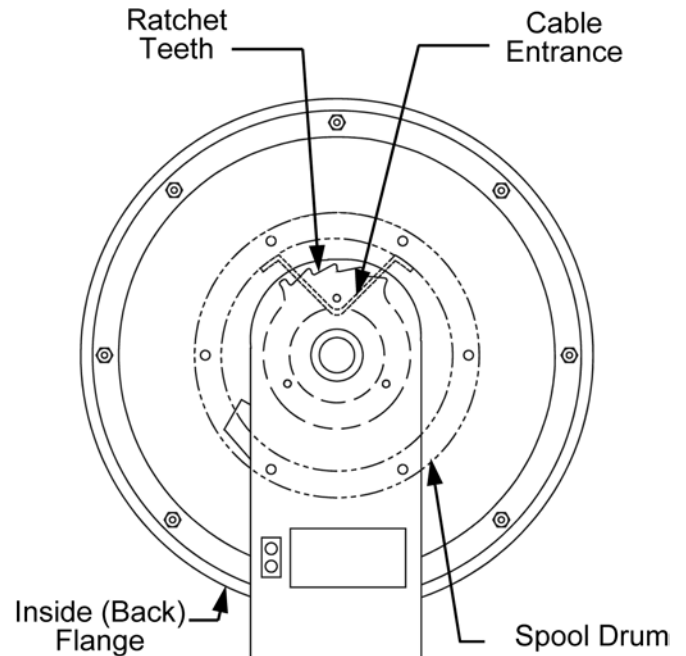

Figure 1



Proper Drum Orientation

Figure 4

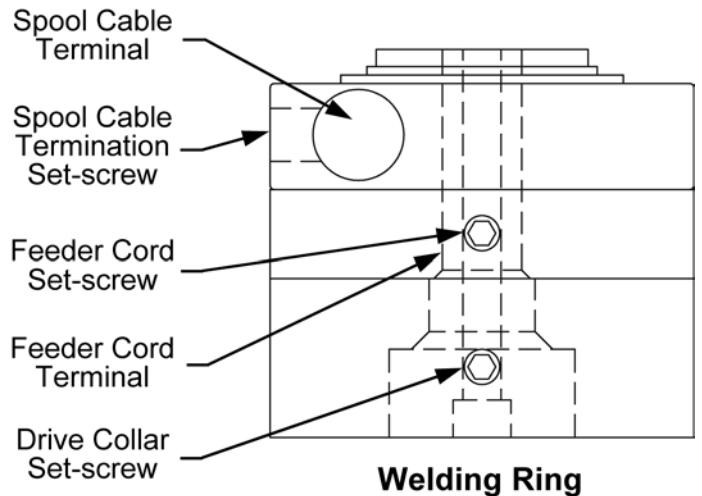

Figure 3a

## 2.0 Installation

### 2.6 Spring Tension Adjustment

**2.6.1 WARNING:** Do not allow cable to retract without restraining the retraction speed. Walk the cable back to the reel during the spring tension adjusting process. Always maintain two full cable wraps on drum at maximum cable extension, size cable length accordingly.

2.6.2 To assure that the cable will retract properly and operate under the correct tension, the reel should be tested. Install cable on drum but do not connect the free end of cable. Securely mount reel before testing.

2.6.3 Pull the cable out the intended travel distance and allow it to rewind. This procedure should be repeated five (5) to ten (10) times in order to set the spring. Walk the cable back to the reel during the spring tension adjusting process.

#### Rotate Spool while holding Cable to test the Spring Tension

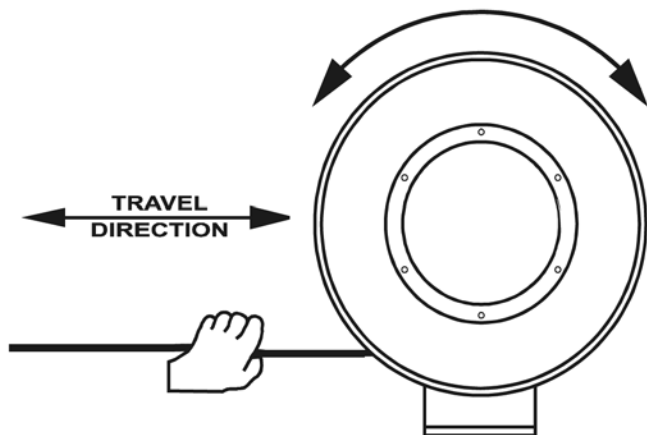

Viewing from Slip Ring Cover

2.6.4 With all the cable wound on the reel, grasp the end of the cable and rotate the drum and cable together in a clockwise direction in order to pre-tension the spring. The number of pre-tension turns is determined by cable size and footage. Usually, two to three turns is sufficient, but additional turns may be used if testing indicates that the cable will not fully retract as desired with just two turns (see Note 2.6.5).

#### Adding Spring Tension

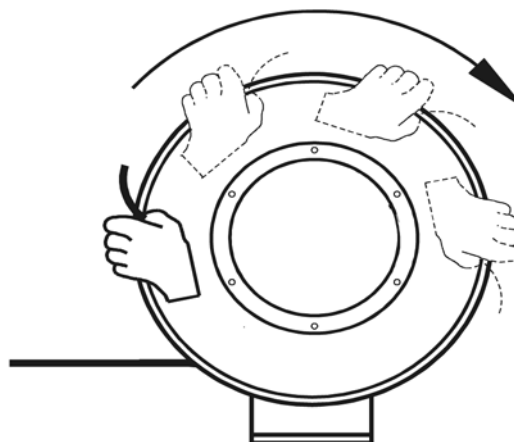

Viewing from Slip Ring Cover

2.6.5 Feed the end of the cable through the cable guide and pull the cable out the required length. Note: Total number of spool revolutions, including pre-tension turns, must not exceed the limits in the following table:

Spring model designation stated in reel description on invoice and packing slip.					
No. of Turns	Models w/#	Motor #	No. of Turns	Models w/#	Motor #
23	J	PR89	30	K	35001
23	JP	PR89P	60	KS	35002
46	JS	PR89S	30	KP	35003

Consult the factory or your representative if number of spool turns is not within parameter.

2.6.6 Repeat steps 2.6.3 to 2.6.5, if necessary, to add tension. To decrease tension, rotate drum and cable counter-clockwise.

#### Adding Spring Tension

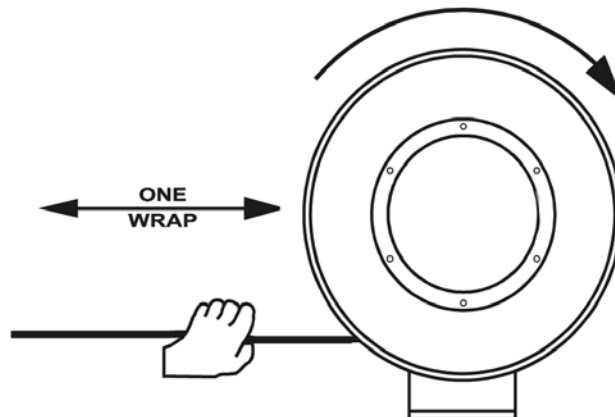

## 2.0 Installation

### 2.7 Power Connections

(For Welding Reels See Section 2.5 and Figure 3a.)

2.7.1 Provide power source with over-current protection to prevent overheating of the reel and cable.

2.7.2 Connect the supply cable to the terminal ring at the top of the slip ring. Wire according to Color Code Chart on page 9.

2.7.2.1 Be sure the GREEN (ground) wire is connected to the green wire slip ring using the top terminal block.

2.7.3 Slide the supply cable back through the shaft to eliminate excess slack at the terminal block. Failure to do so may cause Ring to short out due to excessive wear on insulation of the supply lead(s).

2.7.4 Be sure the supply leads will not come in contact with the slip ring cover or the reel shaft.

2.7.5 If a supply cable entrance watertight is used, be sure gland size is correct for cable diameter. Tighten to seal and to prevent cable pullout. The watertight needs to have 1" NPT thread.

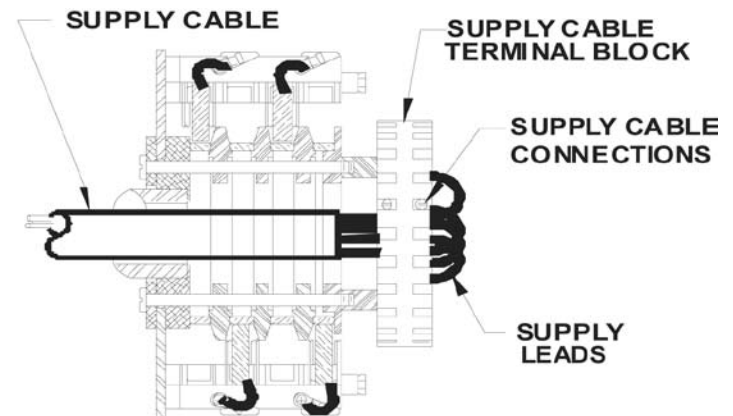

## 3.0 Operation

3.1 Do not exceed the voltage or amperage rating of the cable. Overheating, fire, damage to equipment or personal injury could result.

3.2 Do not allow cable to retract without restraining retraction speed.

3.3 Operate the reel within the cable size and length and spring tensioning limits for which it was intended.

3.3.1 Keep two wraps of cable on the reel at maximum extension to avoid excessive tension on the cable and to prevent pullout of cable from entrance watertight.

3.3.2 The spring should not be wound to the last two turns at maximum payout to avoid over-stressing the spring(s), thus reducing its life or damaging the reel.

3.4 Keep the reel and cable clean to avoid excessive wear and damage.

3.5 Arrange for maintenance service if damage is found on the cable or reel.

3.6 Cable should be fully retracted when not in service to maximize spring life.

## 4.0 Maintenance

**4.1 WARNING: Be sure power is off for maintenance.**

### 4.2 Lubrication

4.2.1 All components requiring lubrication are lubricated for life at the factory. Additional lubrication is not required.

4.2.2 Do not apply any lubricants or solvent cleaning agents to slip ring, brush or insulator surfaces.

## 4.0 Maintenance

### 4.3 Inspections

4.3.1 Periodically check the reel for any loose or missing fasteners. Tighten or replace as necessary.

4.3.2 The slip ring assembly should be checked periodically as follows:

4.3.2.1 Clean to remove dust and dirt from the slip ring housing area and all slip ring assembly and brush surfaces.

4.3.2.2 Brushes should be centered on slip rings and brush springs should be seated in terminal post grooves. Terminal screw connections should be tight. Check for excessive brush wear. Replace brushes as necessary.

4.3.3 Inspect cable for damage or wear which would make it unsafe to use.

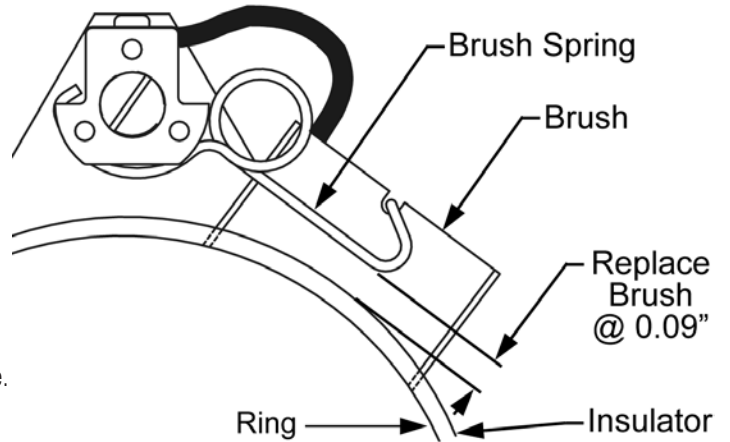

### 4.4 Slip Ring Replacement

4.4.1 The slip ring assembly should be replaced, not rebuilt, if it becomes damaged.

4.4.2 Follow steps 4.5.5 through 4.5.8 to remove the slip ring assembly.

4.4.3 Carefully and thoroughly clean the inside of the reel drum and the slip ring cover.

4.4.4 Follow steps 4.5.5 through 4.5.8 in reverse order to install the new slip ring stack.

4.4.5 Replace cover Gasket if damaged.

**Caution: Damaged gaskets affect UL rating of the reel.**

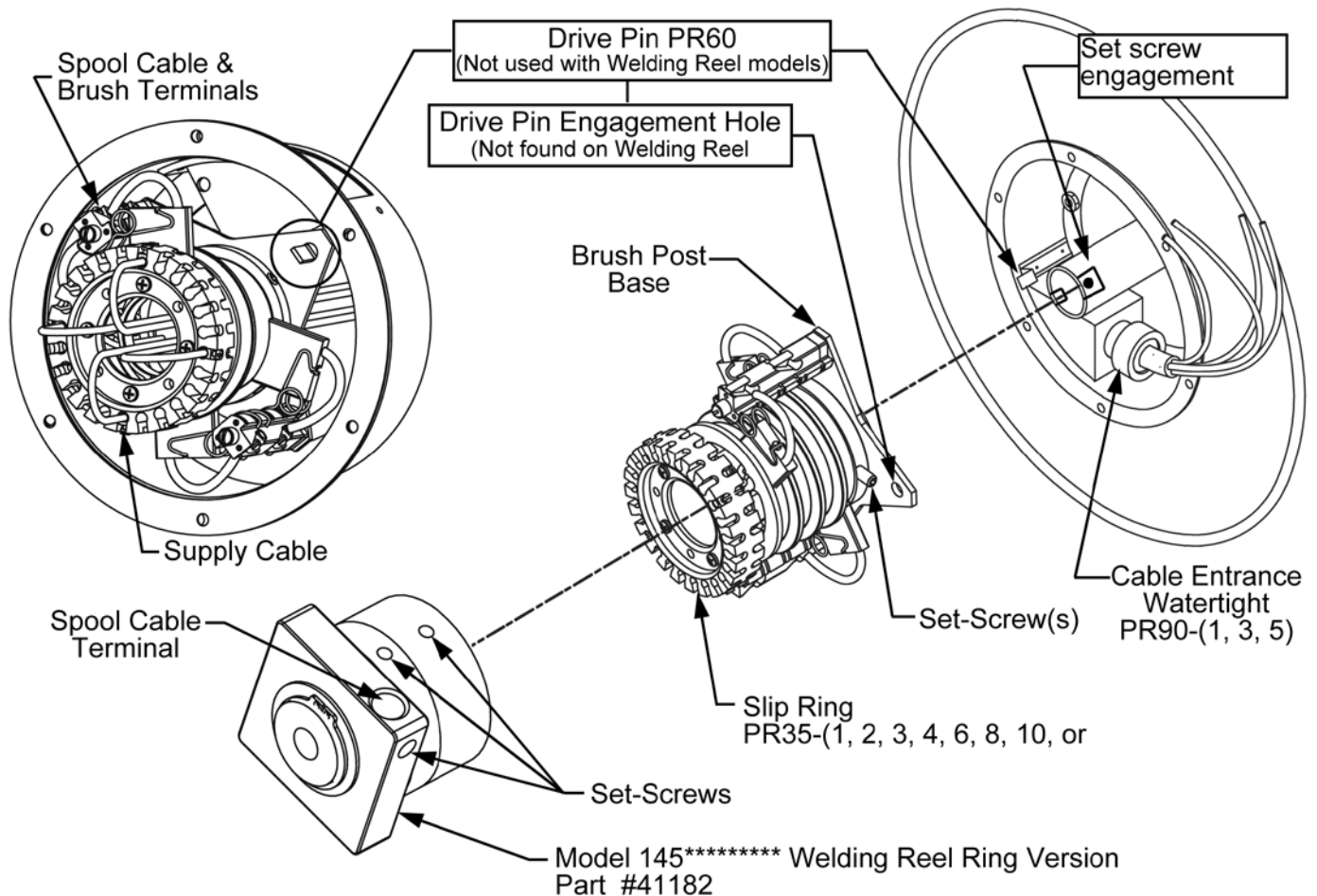

### 4.5 Cable Replacement

- 4.5.1 Replacement cable should be the same size and length as existing cable. Any variations to cable specifications should be pre-approved by the factory.
- 4.5.2 Disconnect all electrical service to the reel before replacing the cable. Follow Lock-Out/Tag-Out procedures as outlined by OSHA.
- 4.5.3 Disconnect the terminal outboard end of the cable and allow cable to retract onto spool. Ensure all spring tension is off by manually rotating the spool.
- 4.5.4 Remove the cable from the spool by looping it over the spool flange and slip ring cover. Make sure the cable end is through the cable guide.
- 4.5.5 Remove the six (6) nuts holding the slip ring cover. Remove cover and gasket. Reinstall (2) nuts finger tight to hold the flange in place.
- 4.5.6 Loosen the supply cable terminal screws (set-screws on Welding Reel Ring) and release the supply cable leads from the terminal block of slip ring.
- 4.5.7 Loosen the brush post terminal screws (set-screws on Welding Reel Ring) and release the cable leads.
- 4.5.8 Use 1/8" Allen Wrench to loosen the set screw and remove the slip ring stack.
- 4.5.9 Remove the watertight nut, gripping ring, bushing and the cable to be replaced.
- 4.5.10 Obtain the replacement cable of the correct size and length and strip the cable end to match the old cable.
- 4.5.11 Carefully and thoroughly clean the inside surfaces of both flanges and the drum.
- 4.5.12 Follow instructions 2.5.4 through 2.5.13 to install the replacement cable, taking care to avoid twisting the cable while winding it onto the reel. Care should also be taken to match the color coded cable leads. (For additional information on wiring, see Section 2.7 Power Connections.)

### 4.6 Spring Motor Replacement

- 4.6.1 **CAUTION:** Do not open the spring motor or personal injury may result.
- 4.6.2 The spring replacement process is determined by the spring configuration and cannot be performed in the field. The entire spring motor assembly must be replaced as a unit. See description on Conductix-Wampfler label to identify spring. (Ref pg 3.)
- 4.6.3 Disconnect all electrical power to the reel before beginning any maintenance or service.
- 4.6.4 Remove the slip ring from the shaft by following the procedure outlined in Section 4.4.
- 4.6.5 Remove the (4) nuts in the bottom of the drum. This may require removing the watertight in order to access all nuts. Lift the cable, drum, and front flange together and set aside.
- 4.6.6 Remove the shaft coupling.
- 4.6.7 Remove the spring motor by unscrewing the shaft from the mounting base.
- 4.6.8 Remove packing material from the replacement spring motor and attach it to the mounting base.
- 4.6.9 Re-assemble spring reel in reverse order with the new spring motor. Note the following:
  - A. Replace gaskets as needed.
  - B. Ratchet must be in the deactivated position (see figure for Section 2.4).
  - C. Shaft must be fully seated on base before installing coupling and watertight.
  - D. Reactivate ratchet to ensure proper alignment.
  - E. Verify drum and ratchet teeth orientation per Figure 4, page 9.
- 4.6.10 Reassemble the reel by following the instructions in Section 2.5.6 through 2.5.11; refer to Color Code Chart on page 9.
- 4.6.11 Adjust spring tension by following the procedure in Section 2.6.

## Troubleshooting

PROBLEM	POSSIBLE CAUSE	SOLUTION
Reel will not retract cable but has some tension.	<ol style="list-style-type: none"> <li>1) Improper pretension.</li> <li>2) Incorrect reel for application (lift vs. stretch)</li> <li>3) Improper cable or cable length installed.</li> <li>4) Cable guide adjustment.</li> </ol>	<ol style="list-style-type: none"> <li>1) See Sec. 2.6 Spring Tension Adjustment.</li> <li>2) Quantify supplication vs. reel selection.</li> <li>3) Install correct cable type and length.</li> <li>4) Check guide alignment (see Sec. 2.2 and 2.3)</li> </ol>
Reel does not have any spring tension.	<ol style="list-style-type: none"> <li>1) Broken spring. *Quantify application to prevent recurrence.</li> </ol>	<ol style="list-style-type: none"> <li>1) Replace spring motor (See Sec. 4.6)</li> </ol>
Ratchet will not activate.	<ol style="list-style-type: none"> <li>1) Broken ratchet pawl spring.</li> <li>2) Lock-out option arm deactivated.</li> </ol>	<ol style="list-style-type: none"> <li>1) Replace ratchet pawl spring.</li> <li>2) Activate lock-out arm (See Sec. 2.4)</li> </ol>
Ratchet will not deactivate.	<ol style="list-style-type: none"> <li>1) Over-extension of reel.</li> </ol>	<ol style="list-style-type: none"> <li>1) Manually rotate reel spool to deactivate ratchet. Do not over-extend. (Guide adjustment may prevent lock-up when over-extended.)</li> </ol>
Cable wraps improperly (uneven wrapping, wraps above or jumps flange).	<ol style="list-style-type: none"> <li>1) Reel mounting not level.</li> <li>2) Cable retraction rate too high.</li> <li>3) Cable guide out of adjustment.</li> <li>4) Improper cable or cable length installed</li> </ol>	<ol style="list-style-type: none"> <li>1) Mount reel on level surface.</li> <li>2) Maintain steady retraction rate.</li> <li>3) Properly adjust cable guide (see Sec. 2.2 and 2.3).</li> <li>4) Install correct cable type and length (See Sec. 1.5 and 2.5).</li> </ol>
Cable twisting or knotting.	<ol style="list-style-type: none"> <li>1) Improperly installed cable.</li> <li>2) Cable rubbing on or bending around fixed object.</li> <li>3) Excessive spring tension.</li> <li>4) Inadequate anchoring of cable.</li> </ol>	<ol style="list-style-type: none"> <li>1) See Sec. 2.5 Cable Installation.</li> <li>2) Check roller guide for function and cable payout path (see Sec. 2.3).</li> <li>3) Quantify application vs. reel selection. Also check pretension.</li> <li>4) Adjust anchoring method i.e. and strain relief.</li> </ol>
Open or intermittent circuit.	<ol style="list-style-type: none"> <li>1) Inadequate connection.</li> <li>2) Loss of brush contact to slip ring.</li> <li>3) Cable defective.</li> </ol>	<ol style="list-style-type: none"> <li>1) Check all termination points.</li> <li>2) Check brush wear, spring tension &amp; alignment.</li> <li>3) Perform continuity check on cable termination points.</li> </ol>
Circuit trips and/or Pitted burned rings or brushes.	<ol style="list-style-type: none"> <li>1) Inadequate amp rating of reel selection.</li> </ol>	<ol style="list-style-type: none"> <li>1) Quantify application requirements vs. reel &amp; cable rating (see Sec. 1.5).</li> </ol>
Circuit arcing.	<ol style="list-style-type: none"> <li>1) Amp or voltage above rating of reel.</li> <li>2) Excessive carbon dusk accumulation.</li> <li>3) Water or moisture in slip ring.</li> <li>4) Loss of brush to ring contact.</li> </ol>	<ol style="list-style-type: none"> <li>1) Quantify application requirements vs. reel &amp; cable rating (see Sec. 1.5).</li> <li>2) Clean dust from inside slip ring.</li> <li>3) Check gasket seal.</li> <li>4) Replace brush and/or brush spring.</li> </ol>

# 6.0 Replacement Parts

## Parts Description

## Reel Catalog Number:

**Recommended Spare Parts:**

② ⑦ ③  
⑩ ⑫

③

Gaskets	
PR55	
PR57	

⑫

**Brush Replacement Kit**  
PR95 (1 Brush & 1 Spring)

①

Cover Selection				
	Spool Drum Size			
	PA	PB	PC	
Slip Ring Size	01	PR13-3	PR13-3	PR13-3
	02	PR13-4	PR13-3	PR13-3
	03	PR13-4	PR13-3	PR13-3
	04	PR13-4	PR13-3	PR13-3
	06	PR13-6	PR13-4	PR13-3
	08	PR13-8	PR13-6	PR13-4
	10	N/A	PR13-8	PR13-6
	12	N/A	PR13-8	PR13-6
	WI	PR13-3	PR13-3	PR13-3

④

Drum Width	Cable Drum	Guide Arm
A = 3.0	PR86-3	PR87-3
B = 4.5	PR86-4	PR87-4
C = 6.0	PR86-6	PR87-6

②

Slip Ring	
PR35-01	PR35-06
PR35-02	PR35-07
PR35-03	PR35-08
PR35-04	PR35-10
PR35-05	PR35-12
W1 = 41182	

⑭

**Cap Plug**  
03688  
B & C Only

**POWEREEL Component Code**

**P | B | J | S - 12 | 03 - 60**

**Installed Cable**

Blank = No Cable Installed

## = Length of Cable (ft.)

3/32 = Length of Grounding Cable

⑦

SPRING MOTOR	
J Only =	PR89 = 1 Spring
JP =	PR89P = 2 / Parallel
JS =	PR89S = 2 / Series
K Only =	35001 = 1 Spring
KP =	35003 = 2 / Parallel
KS =	35002 = 2 / Series

**Wire Gauge**  
Reel with Cable Only

**Cable Gauge**

## = Wire/Cable Gauge

3/32 = Jacketed Aircraft Cable

**Number of Conductors**

⑬

Cable Kit/Waterlight			
AWG	No. of Conductors		
16AWG	26	7-12	-
14AWG	23	4-8	9-12
12AWG	-	24	6-8
10AWG	-	24	5&6
PN	PR80-1	PR80-3	PR80-5
Cable Range	0.31-0.56	0.50-0.75	0.7-0.95

Requires two (2) additional feet of cable:  
le: 60 = 62

⑪

Base Assembly	
PR04A-2	
(Item 10: pr91 included)	

⑤

**Outer Flange**  
PR08

⑩

**Ratchet Repair Kit**  
PR 91 (as of 3/96 only)

Note: Items 7 & 11 must be purchased as a set for units manufactured before 3/96.

⑨

**Shaft Coupling**  
PR47

FGK option not shown refer to Pg. 7

0.31-18 x 0.63  
Hex Head Cap Screw  
0.31 Lock Washer

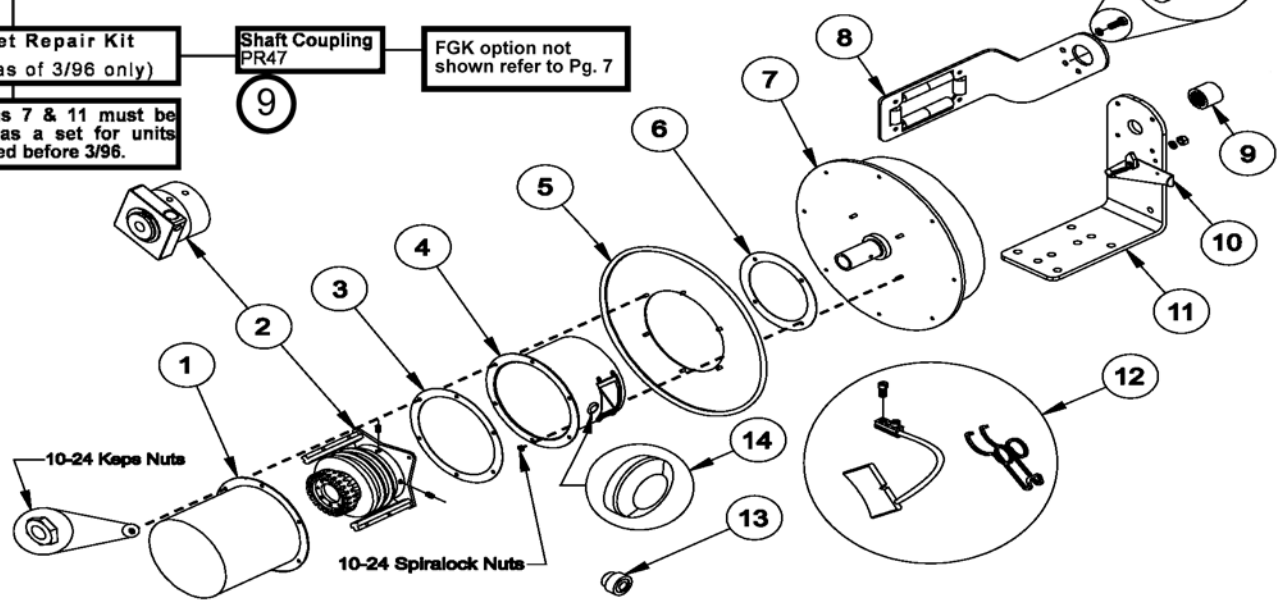

Consult the Factory for Custom Application Part Numbers

## Notes

## Notes

## Notes

[www.conductix.com](http://www.conductix.com)

**Conductix-Wampfler**

10102 F Street  
Omaha, NE 68127  
USA

Customer Support  
Phone: 800 521 4888  
Fax: 800 780 8329

Phone: 402 339 9300  
Fax: 402 339 9627

[info.us@conductix.com](mailto:info.us@conductix.com)  
[www.conductix.com](http://www.conductix.com)

