

# Cable Reel Series 1200

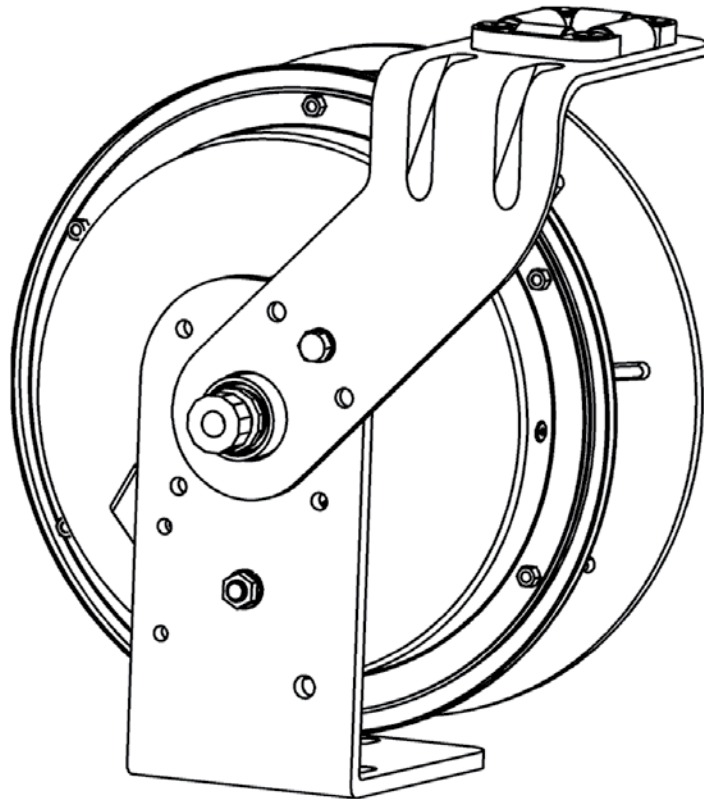

# Conductix Incorporated

The technical data and images which appear in this manual are for informational purposes only. **NO WARRANTIES, EXPRESS OR IMPLIED, INCLUDING WARRANTIES OF MERCHANTABILITY OR FITNESS FOR A PARTICULAR PURPOSE, ARE CREATED BY THE DESCRIPTIONS AND DEPICTIONS OF THE PRODUCTS SHOWN IN THIS MANUAL.** Conductix makes no warranty (and assumes no liability) as to function of equipment or operation of systems built according to customer design or of the ability of any of its products to interface, operate or function with any portions of customer systems not provided by Conductix.

Seller agrees to repair or exchange the goods sold hereunder necessitated by reason of defective workmanship and material discovered and reported to Seller within one year after shipment of such goods to Buyer.

Except where the nature of the defect is such that it is appropriate, in Seller's judgment, to effect repairs on site, Seller's obligation hereunder to remedy defects shall be limited to repairing or replacing (at Seller's option) FOB point of original shipment by Seller, any part returned to Seller at the risk and cost of Buyer. Defective parts replaced by Seller shall become the property of Seller.

Seller shall only be obligated to make such repair or replacement if the goods have been used by Buyer only in service recommended by Seller and altered only as authorized by Seller. Seller is not responsible for defects which arise from improper installation, neglect, or improper use or from normal wear and tear.

Additionally, Seller's obligation shall be limited by the manufacturer's warranty (and is not further warranted by Seller) for all parts procured from others according to published data, specifications or performance information not designed by or for Seller.

Seller further agrees to replace or at Seller's option to provide a refund of the sales price of any goods that do not conform to applicable specifications or which differ from that agreed to be supplied which non-conformity is discovered and forthwith reported to Seller within thirty (30) days after shipment to the Buyer. Seller's obligation to replace or refund the purchase price for non-conforming goods shall arise once Buyer returns such goods FOB point of original shipment by Seller at the risk and cost of Buyer. Goods replaced by Seller shall become the property of Seller.

There is no guarantee or warranty as to anything made or sold by Seller, or any services performed, except as to title and freedom from encumbrances and, except as herein expressly stated and particularly, and without limiting the foregoing, **there is no guarantee or warranty, express or implied, of merchantability or of fitness for any particular purpose or against claim of infringement or the like.**

Seller makes no warranty (and assumes no liability) as to function of equipment or operation of systems built to Buyer's design or of the ability of any goods to interface, operate or function with any portions of Buyer's system not provided by Seller.

Seller's liability on any claim, whether in contract, tort (including negligence), or otherwise, for any loss or damage arising out of, connected with, or resulting from the manufacture, sale, delivery, resale, repair, replacement or use of any products or services shall in no case exceed the price paid for the product or services or any part thereof which give rise to the claim. In no event shall Seller be liable for consequential, special, incidental or other damages, nor shall Seller be liable in respect of personal injury or damage to property not the subject matter hereof unless attributable to gross misconduct of Seller, which shall mean an act or omission by Seller demonstrating reckless disregard of the foreseeable consequences thereof.

Seller is not responsible for incorrect choice of models or where products are used in excess of their rated and recommended capacities and design functions or under abnormal conditions. Seller assumes no liability for loss of time, damage or injuries to property or persons resulting from the use of Seller's products. Buyer shall hold Seller harmless from all liability, claims, suits and expenses in connection with loss or damage resulting from operation of products or utilization of services, respectively, of Seller and shall defend any suit or action which might arise there from in Buyer's name - provided that Seller shall have the right to elect to defend any such suit or action for the account of Buyer. The foregoing shall be the exclusive remedies of the Buyer and all persons and entities claiming through the Buyer.

## 1.0 Safety Instructions

- 1.1 Electrical Warnings
- 1.2 Operational Warnings
- 1.3 Maintenance Warnings
- 1.4 UL Rating
- 1.5 Electrical Rating
- 1.6 Labels and Marking

## 2.0 Installation

- 2.1 Application Types
- 2.2 Mounting
- 2.3 Roller Guide
- 2.4 Ratchet
- 2.5 Cable Installation
- 2.6 Feeder Cord Connections
- 2.7 Spring Tension Adjustment

## 3.0 Operation

## 4.0 Maintenance

- 4.1 Maintenance Warnings
- 4.2 Lubrication
- 4.3 Inspections
- 4.4 Slip Ring and Feeder Cord Replacement
- 4.5 Cable Replacement
- 4.6 Spring Motor Replacement

## 5.0 Troubleshooting

## 6.0 Replacement Parts

- 6.1 Part Descriptions
- 6.2 Exploded View
- 6.3 Order Form

### RECORD

The catalog number of the reel and the serial number of the reel are required when ordering replacement parts or discussing the reel with the factory. Please record this information now in the spaces provided below.

CATALOG NO. OF REEL \_\_\_\_\_

SERIAL NO. \_\_\_\_\_

DATE INSTALLED \_\_\_\_\_

# Overview

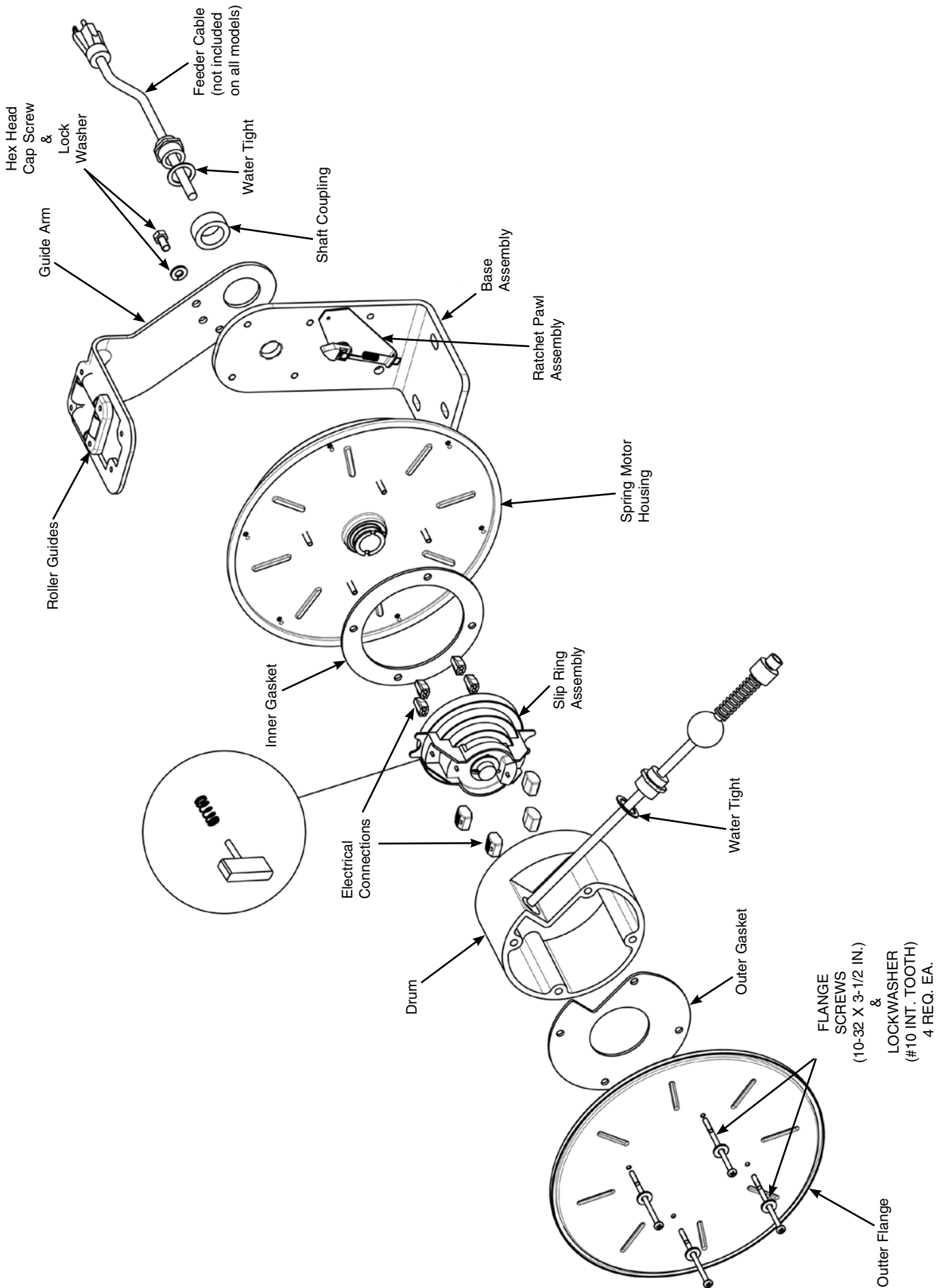

# 1.0 Safety

## 1.1 ELECTRICAL WARNINGS

- 1.1.1 Properly ground this equipment before use in accordance with both the National Electric Code and local electrical codes and ordinances.
- 1.1.2 Disconnect the electrical power from the cable reel before any service functions are performed.
- 1.1.3 Do not use this cable reel for loads greater than the current rating listed on the label and voltage greater than 300V with SJOW-A cable OR 600V with SOW-A cable. The ampacity (current) rating of the cable must be in accordance with the National Electric Code.
- 1.1.4 Electrical wiring on the reel must be done by a qualified electrician.

## 1.2 OPERATIONAL WARNINGS

- 1.2.1 Exercise care when handling the cable reel during normal operation. This cable reel has a rotating spool powered by springs under tension.
- 1.2.2 Do not allow cable to retract without restraining the retraction speed.
- 1.2.3 Do not disassemble the spring motor for any reason. Serious personal injury could result. This cable reel is equipped with springs under tension. Contact the factory for assistance:

In the US call: 1-800-521-4888
In Canada call: 1-800-667-2487

## 1.3 MAINTENANCE WARNINGS

- 1.3.1 Do not use cable different from that for which the reel is intended. Changes in diameter, weight per foot, length of cable or flexibility will affect the operation of the reel.
- 1.3.2 Mounting hardware and fasteners should be installed to maintain tightness under vibration and checked periodically to assure tightness.
  - 1.3.2.1 Overhead installation mountings should be such that the reel is not suspended by bolts in tension. A safety chain or cable is strongly recommended to minimize damage and/or possible injury in the event of mounting failure.
- 1.3.3 **WARNING:** Modification of this equipment may cause excessive wear and will void the warranty. Contact the manufacturer regarding changes or modifications of equipment which could affect reliability or safety.

## 1.4 UL RATING

- 1.4.1 Reels that are listed UL & CSA are indicated in catalog.
- 1.4.2 The following requirements apply for UL & CSA listed POWEREEL products:
- 1.4.3 Listed cable reels are intended for General/Commercial/Industrial use and are provided with permanent mounting means. They must be wired by a qualified electrician.
- 1.4.4 UL / CSA listed type SJOW-A, 300V- rated, 90°C flexible cable or type SOW-A, 600V- rated, 90°C flexible cable must be used for the supply cable (if flexible cable is used) and for the load end cable (active cable).

# 1.0 Safety

## 1.5 ELECTRICAL RATING

### 1.5.1 Reels Equipped with or without Cable

1.5.1.1 Reels equipped with cable are rated and should not be used at voltages and/or amperes above the rating on the reel. Please consult factory prior to making any changes in volts and amps of cable, as a change could affect reliability or safety.

(see section 1.3.3 & 1.6.3)

Color Code Chart		
Location of Ring	No. of Conductor	Base Color
top	Ground	Green
2nd from top	2	Black
3rd from top	3	White
bottom	4	Red

SJOW-A (90°C)		SJ00W-A (90°C)		SOW-A (90°C)		SO0W-A (90°C)	
300 Volt		300 Volt		600 Volt		600 Volt	
Cable AWG / # of Cond.	Ampacity	Cable AWG / # of Cond.	Ampacity	Cable AWG / # of Cond.	Ampacity	Cable AWG / # of Cond.	Ampacity
16/3	10.0	16/3	10.0	16/3	10.0	16/3	10.0
16/4	8.0	16/4	8.0	16/4	8.0	16/4	8.0
14/3	15.0	14/3	15.0	14/3	15.0	14/3	15.0
14/4	12.0	14/4	12.0	14/4	12.0	14/4	12.0
12/3	20.0	12/3	20.0	12/3	20.0	12/3	20.0
12/4	16.0	12/4	16.0	12/4	16.0	12/4	16.0

## 1.6 LABELS & MARKING

1.6.1 Every cable reel is marked with a label which includes the CONDUCTIX name and logo, the product catalog number, the individual product serial number, NEMA rating, Amps, Volts, Watts and Cable Footage.

1.6.2 The UL / CSA Listing Mark is applied to reels that comply with the applicable requirements and identified with the authorized mark.

1.6.3 The maximum cable footage, amperage and voltage rating for every cable reel supplied without cable is marked on the CONDUCTIX Identification Label. The actual cable installed should not differ from what is indicated on the CONDUCTIX label. If the cable must be different please consult the factory prior to installing the cable to ensure the change will not affect the reliability of the reel or the safety of the people working with the reel.



**LISTED  
REEL  
6 7 N 6**



## 2.0 Installation

### 2.1 Application Types

#### 2.1.1 Stretch Applications

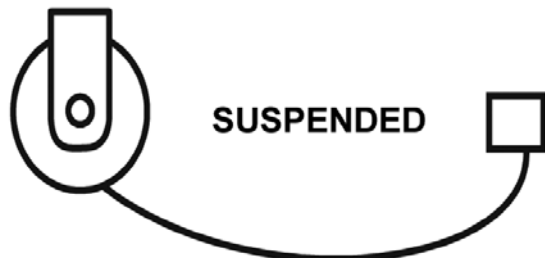

2.1.1.1 The cable is suspended without any intermediate support. Stretch reels generally require a line pull equal to two times the weight of the cable, which allows approximately 10% sag at full extension. On long applications where sag cannot be tolerated, it is sometimes desirable to put supports at intervals of 5 to 10 feet.

#### 2.1.3 Drag Applications

##### STATIONARY

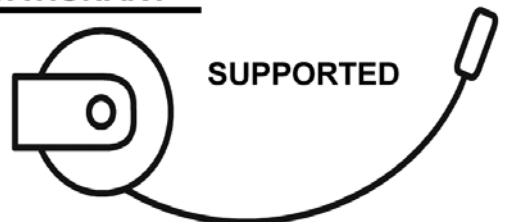

2.1.3.1 The reel is mounted on a stationary object and is required to drag the cable over the surface to the reel. The cable is supported by the ground or some type of cable tray. A ball stop may be required. All 1200 Series reels sold with cable have a ball stop installed on the reel.

#### 2.1.2 Lift Applications

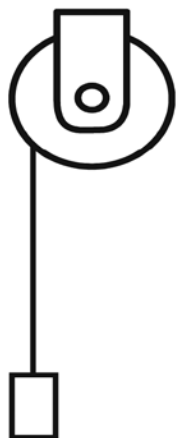

2.1.2.1 The cable is lifted vertically in lift applications. The reel is normally designed to handle only the total weight of the cable. Some lift applications may require a ball stop and ratchet to control the length of cable to be retracted.

#### 2.1.4 Retrieve Applications

##### STATIONARY

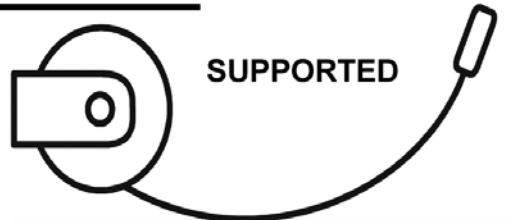

2.1.4.1 The reel is mounted on the moving object and winds up or pays out the cable as the machine approaches or moves away from the fixed end.

### 2.2 Mounting

#### 2.2.1 Standard Mounting

2.2.1.1 The reel may be mounted by bolting the base to any flat surface which is structurally sound enough to support it and the forces of winding and unwinding the cable.

2.2.1.2 The spool drum must rotate on a horizontal axis.

2.2.1.3 The reel should be oriented so that the cable extends perpendicular to the rotation of the spool. The total cable deflection should not exceed 30°.

2.2.1.4 If deflection is constant to either side of the reel and operation is impaired, re-mount the reel.

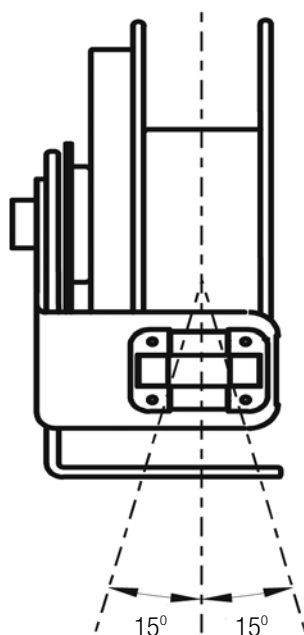

Cable Deflection with Roller Guide

2.2.1.5 If the angle of deflection exceeds 30° a Pivot Base should be used, otherwise excessive cable wear and unreliable operation will result.

2.2.1.6 We recommend a safety chain for all overhead installations. Attach the safety chain using the 0.39 hole provided in the base.

## 2.0 Installation

### 2.2.2 Pivot Base Mounting (Optional Accessory)

2.2.2.1 All 1200 Series Cable Reels can be furnished with a pivot base to allow the reel to rotate and keep the extended cable perpendicular to the application.

2.2.2.2 The PVB Pivot Base will rotate up to 345°. Travel can be limited to 90°, 180°, or 270° by installing an additional roll pin in the appropriate available hole.

2.2.2.3 A pivot base is required carousel or loop track applications.

2.2.2.4 When a pivot base is used the reel must be mounted horizontally ("ceiling" or "floor" mounted).

2.2.2.5 The Roller Guide should be mounted to require the cable to travel perpendicular to the axis of rotation. This will guard against cable twisting and ensure effective swivel action from the pivot base.

2.2.2.6 Swing mount base available, consult factory.

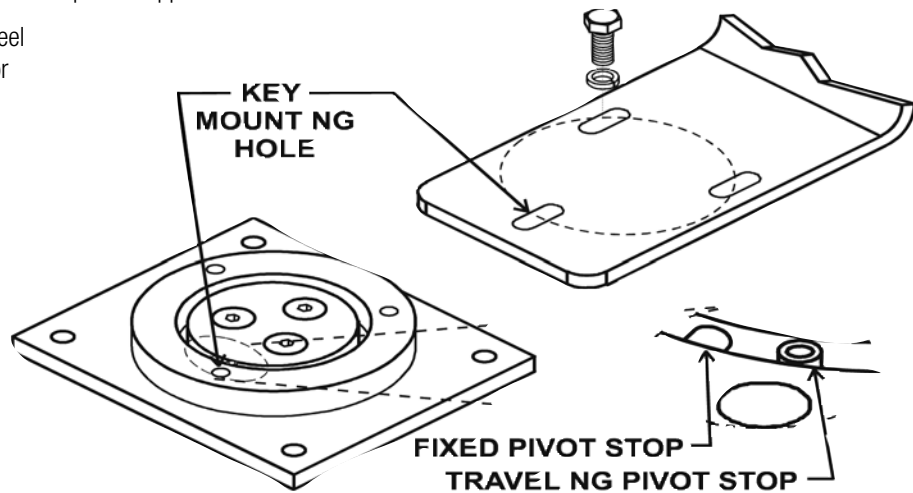

### 2.3 ROLLER GUIDES

2.3.1 All 1200 Series units are equipped with a roller guide. The guide's function is to center the cable on the spool and to help the reel wrap cable more evenly.

2.3.2 The cable should not bear against either end of the spool during winding as this will tend to inhibit level winding of the cable.

2.3.3 The guide should be secured at the best of twelve possible positions so that a minimum change of direction occurs at the guide; otherwise, cable life will be reduced.

2.3.4 The guide arm is shipped attached to the reel. The guide must be located and secured in the most appropriate position with the 5/16-18 x 5/8" hex head screw and lockwasher provided, prior to making any electrical connections.

Roller Guide Locations  
(4 of 12 possible positions shown.)

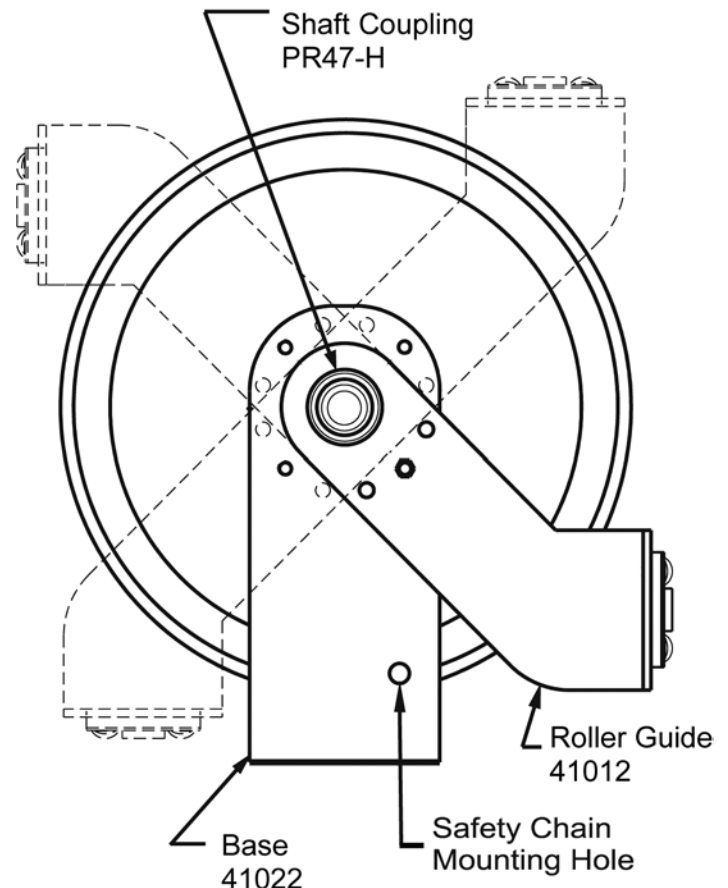

## 2.0 Installation

### 2.4 RATCHET

#### 2.4.1 Ratchet Lock

2.4.1.1 The ratchet lock can be engaged or disengaged, depending upon the application.

#### 2.4.2 Operation with Ratchet

2.4.2.1 The ratchet pawl is spring loaded. It is designed to function in all acceptable mounting configurations.

2.4.2.2 A slight pull on cable will disengage the ratchet.

#### 2.4.3 Operation without Ratchet

2.4.3.1 Disengage the ratchet by pivoting the lock-out bar to the lower position. This will remove the ratchet pawl from the path of the ratchet plate. Locate the dimple on the lock-out bar in the hole provided.

2.4.3.2 **WARNING:** Do not engage the ratchet abruptly. Sudden engagement may cause excessive shock loads to the ratchet pawl.

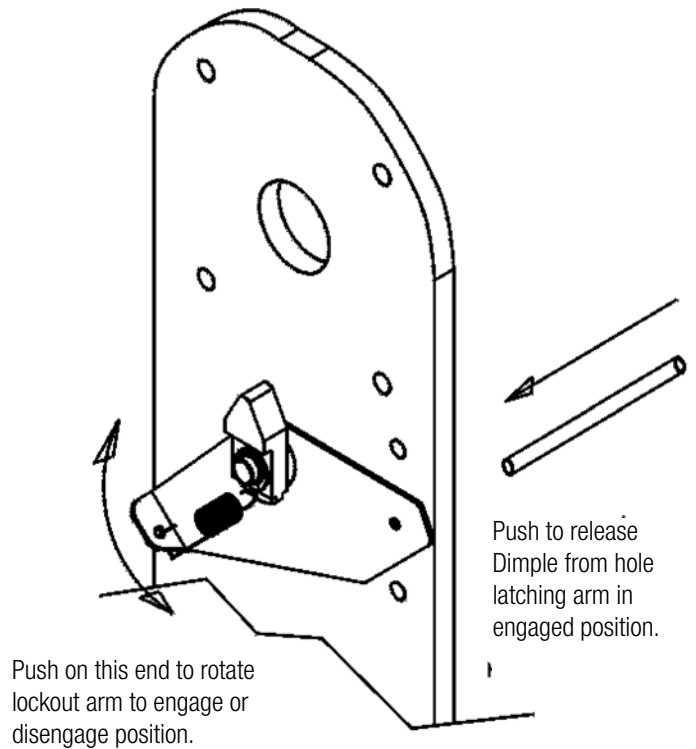

### 2.5 CABLE INSTALLATION

2.5.1 Either of two methods for installing cable on the reel may be used. The first method is to simply lay the cable out straight along the path of travel and wrap onto the reel. The second method requires using a support for the cable being wrapped (see Fig. 1, Page 9). In either method, it is important that the cable not twist or loop.

2.5.2 Remove the (4) screws securing the outer flange. Remove outer flange, gasket and drum from the remaining assembly.

2.5.3 Strip back approximately 6" of cable jacket.

2.5.4 Feed cable through the watertight and the drum, so that 1" of the jacket is through the watertight. Secure a cable-tie 1/4" from the end of the jacket and tighten watertight. Replace inner flange gasket if damaged. (see Fig. 3, Page 9).

2.5.5 Cut the individual wires such that the white and green wires extend 3" beyond the cable jacket and the red and black wire extend 6" beyond the cable jacket. Strip approximately 1/2" of insulation. Insert each cable wire and its corresponding slip ring brush wire into the toggle lock wire connector. Refer to the color code chart in section 1.5.

2.5.6 Perform a continuity check to verify circuits.

2.5.7 Attach outer flange gasket and outer flange to drum (replace outer flange gasket if damaged) Attach with 10-32 x 3-1/2" screws. Longer screws will damage the reel.

2.5.8 Wrap new cable on drum spool (refer to Sec. 2.5.1).

2.5.9 Adjust spring tension by following the procedure in Section 2.7.

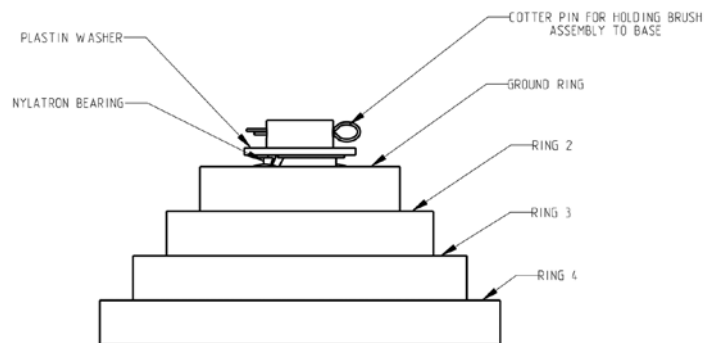

## 2.0 Installation

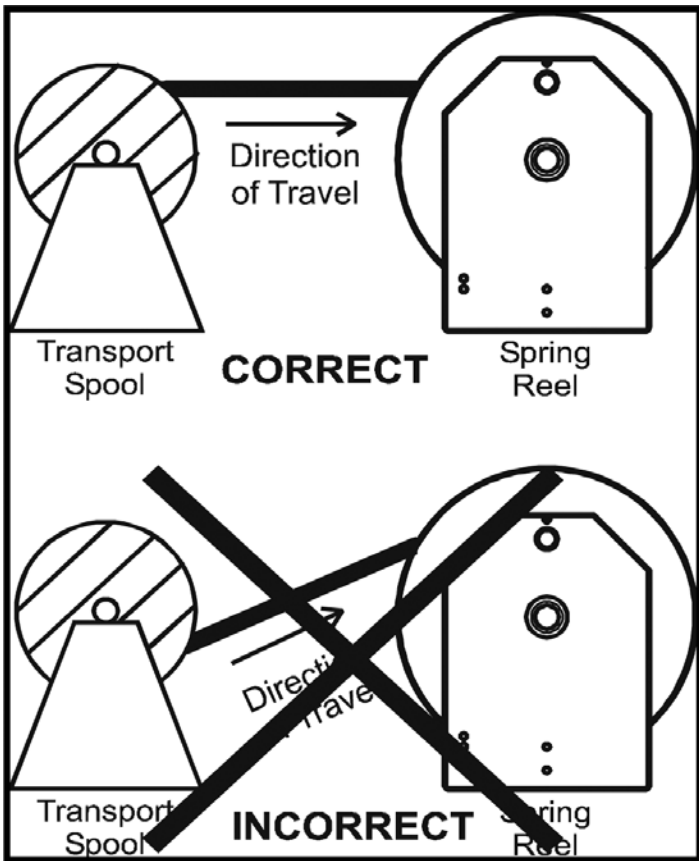

Figure 1

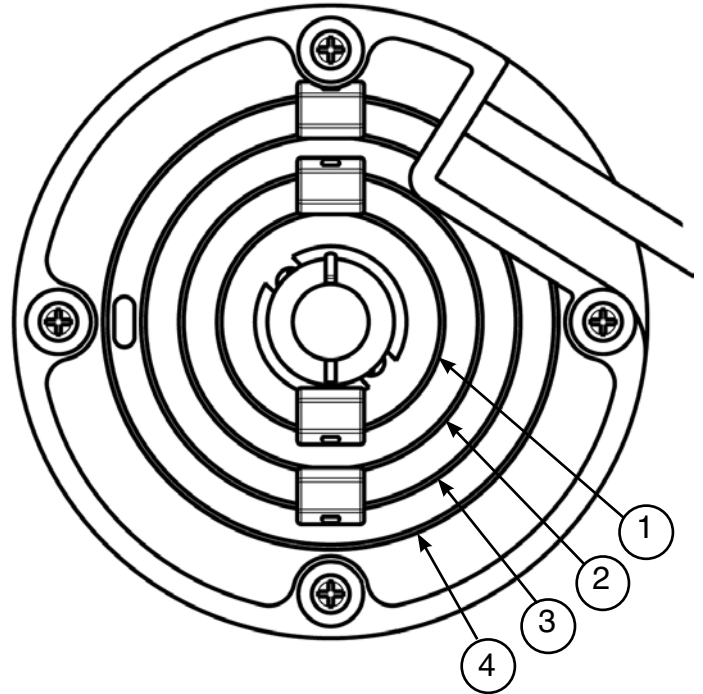
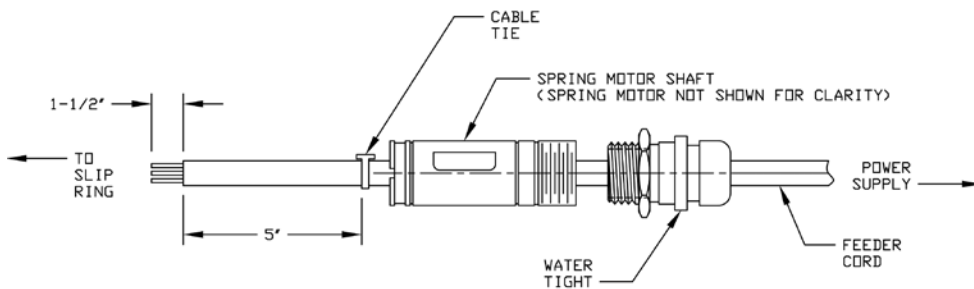
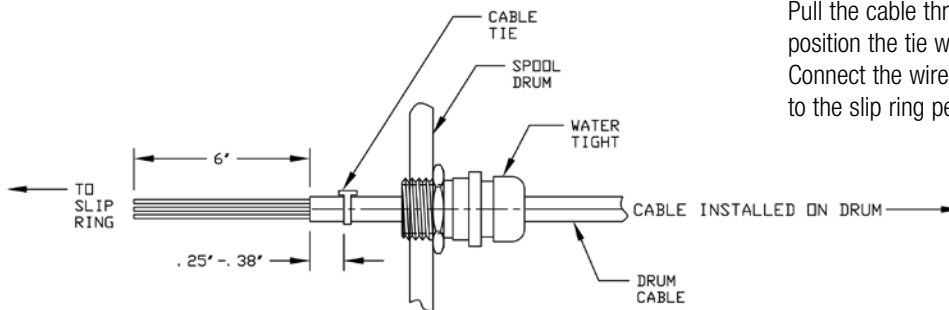

Figure 2



POWER CONNECTION

Feed the Power Connection Cable (Pigtail) through the shaft and cut jacket wires leaving 1-1/2" of wire beyond the jacket. Strip 1/2" of jacket from each wire. Install the cable tie 4" from the end of the cable jacket. Connect the wires to the slip ring leads and install the slip ring per Section 4.4.



SPOOL DRUM CONNECTION

Strip the cable and wires as shown. Install the cable tie 6.25" to 6.38" from the end of the wires. Tighten the water tight in the drum. Pull the cable through the water tight to position the tie wrap against the water tight. Connect the wire leads to the slip ring per Section 4.5.

Figure 3

## 2.0 Installation

### 2.6 FEEDER CORD CONNECTION

- 2.6.1 Power supply should have overcurrent protection to prevent overheating of the reel and cable.
- 2.6.2 Follow procedure in Sec. 4.4 if feeder cord is not installed on reel.
- 2.6.3 Connect feeder cord to power supply, per NEC and local codes.

### 2.7 SPRING TENSION ADJUSTMENT

2.7.1 To assure that the cable will retract properly and operate under the correct tension, the reel should be tested. Install cable on drum but do not connect the free end of cable. Securely mount reel before testing.

2.7.2 Pull the cable out approximately 20 - 30 feet and allow it to rewind. This procedure should be repeated five (5) to ten (10) times in order to set the spring. Walk the cable back to the reel during the spring tension adjusting process.

**2.7.3 WARNING: Do not allow cable to retract without restraining the retraction speed. Always maintain two full cable wraps on drum at maximum cable extension, size cable accordingly.**

2.7.4 With all the cable wound on the reel, grasp the end of the cable and rotate the drum and cable together in a clockwise direction in order to pre-tension the spring. Generally, (1) full turn is adequate for most applications. Use no more than (2) full turns for pre-tension.

2.7.5 Feed the end of the cable through the cable guide and pull the cable out the required length. Note: the number of spool revolutions including the pre-tension turns should not exceed 26 full turns on models with K Spring Motor (41027) or 30 turns on models with G Spring Motor (41028). Consult factory or your representative if number of spool turns are not within parameter.

2.7.6 Repeat step 2.7.3 to 2.7.5 if necessary to add or decrease tension.

2.7.7 All reels with factory installed cable have 1 full pre-wrap on the reel, but has not had the spring tension adjustment process completed.

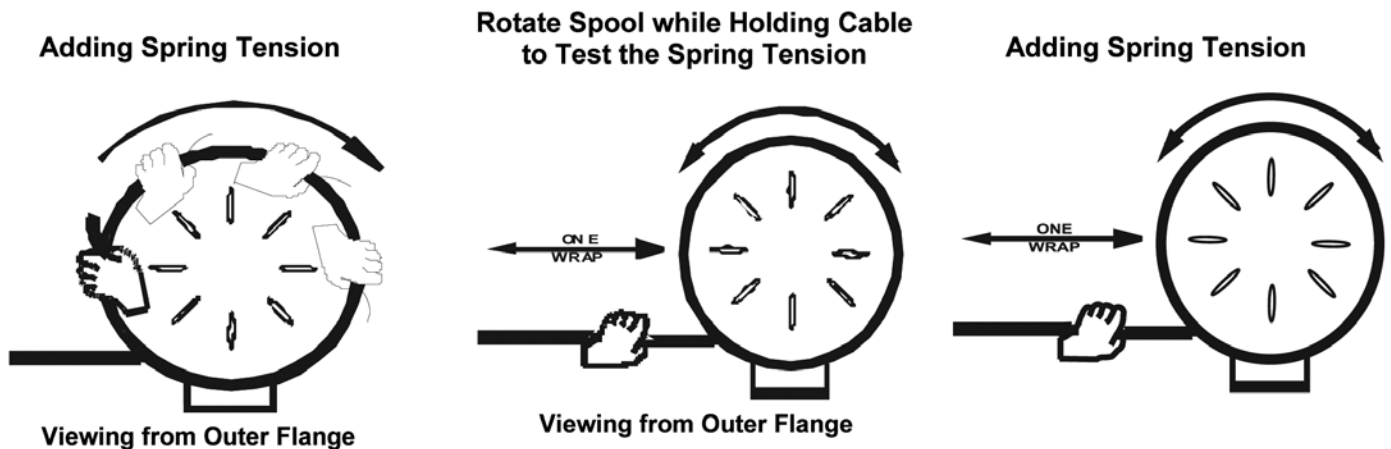

## 3.0 Operation

- 3.1 Do not exceed the voltage or ampere rating of the cable. Do not exceed the voltage or ampere rating of the reel. Overheating, fire, damage to equipment or personal injury could result.
- 3.2 Do not allow cable to retract without restraining the retraction speed.
- 3.3 Operate the reel within the cable size and length and spring tensioning limits for which it was intended.
  - 3.3.1 Two wraps of cable should remain on the reel at maximum extension to avoid excessive tension on the cable entrance watertight.
  - 3.3.2 The spring should not be wound to its last two turns at maximum payout to avoid over-stressing the spring, thus reducing its life or damaging the reel.
- 3.4 Keep the reel and cable clean to avoid excessive wear and damage.
- 3.5 Arrange for maintenance service if damage is found on the cable or reel.
- 3.6 Cable should be fully retracted when not in service to maximize spring life.

## 4.0 Maintenance

### 4.1 WARNING: Be sure the power is off for all maintenance.

### 4.2 LUBRICATION

- 4.2.1 All springs and bearings are lubricated for life at the factory. Additional lubrication should not be required.
- 4.2.2 Do not apply any lubricants or solvent cleaning agents to slip ring, brush or insulator surfaces.

### 4.3 INSPECTIONS

- 4.3.1 Periodically check the reel for any loose or missing fasteners. Tighten or replace as necessary. NOTE: Do not over tighten, this will cause fasteners to snap.
- 4.3.2 The slip ring assembly should be checked periodically as follows:
  - 4.3.2.1 Clean to remove dust and dirt from the slip ring housing area and all slip ring assembly and brush surfaces.
- 4.3.3 Inspect cable for damage or wear which would make it unsafe to use.

## 4.0 Maintenance

### 4.4 SLIP RING & FEEDER CORD REPLACEMENT

4.4.1 NOTE: The slip ring assembly should be replaced, not rebuilt, if it becomes damaged.

4.4.2 Remove the (4) screws securing the outer flange. Remove outer flange and gasket from remaining assembly. Remove or unwrap the cable from the drum and lay it next to the reel.

4.4.3 Disconnect the wires from the spool cable. Remove the drum (black plastic tube) from the reel and place next to the slip ring.

4.4.4 Loosen feeder cord watertight located at the shaft end.

4.4.5 Remove the brush block from the slip ring by removing the cotter pin and washer at the top of the slip ring assembly. Remove the 2 screws securing the slip ring to the shaft (See exploded view)

4.4.6 Remove the slip ring from the shaft while feeding in the feeder cord through the shaft. Cut wires if they are butt spliced or disconnect connectors if locking wire connectors are used. Reinsert the washer and cotter pin after removal of the slip ring from the shaft to keep the assembly together.

4.4.7 Carefully and thoroughly clean the inside surfaces of both flanges and the drum. Inspect both gaskets for damage and replace as necessary. Caution: Damaged gaskets may affect UL / CSA rating of reel.

4.4.8 Remove old feeder cord and Insert approximately 5" -10" of new feeder cord through the watertight and shaft. Secure cable-tie as shown in Fig. 3, Page 9.

4.4.9 Install inner gasket.

4.4.10 Connect the slip ring leads to the feeder cord with the provided wire connectors and install the slip ring on the shaft. Ensure the wire connectors are outside the shaft and under the slip ring body before securing the slip ring to the shaft. Be careful not to over tighten or strip the Phillips head screws.

4.4.11 Install the 2 screws to secure the slip ring to the shaft.

4.4.12 For remaining assembly, follow procedure in section 2.5.5 through 2.5.9 and adjust spring tension per section 2.7.

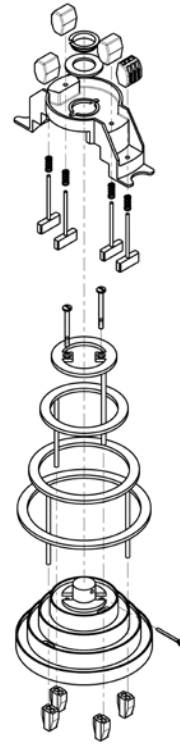

### 4.5 CABLE REPLACEMENT

4.5.1. Replacement cable should be the same size and length as existing cable. Any variations to cable specifications should be pre-approved by the factory.

4.5.2. Disconnect all electrical service to the reel before replacing the cable as per Lock-Out/Tag-Out procedures outlined in OSHA section 1910.147.

4.5.3. Disconnect the terminated service end of the cable and allow the cable to retract onto spool. Make sure the end of the cable is through the roller guide. Ensure all spring tension has been relieved by manually rotating the spool counter clockwise as viewed from outer flange.

4.5.4 Follow procedures outlined in sections 4.4.1 through 4.4.5 and then remove cable.

4.5.5 Carefully and thoroughly clean the inside surfaces of both flanges and the drum. Inspect both gaskets for damage and replace as necessary. Caution: Damaged gaskets may affect UL / CSA rating of reel.

4.5.6 Install inner gasket .

4.5.7 Follow procedure in section 2.5.3 through 2.5.9 and adjust spring tension per section 2.7.

## 4.0 Maintenance

### 4.6 SPRING MOTOR REPLACEMENT

4.6.1 CAUTION: Do not open the spring motor or personal injury may result.

4.6.2 The spring replacement process is determined by the spring configuration and cannot be performed in the field. The entire spring motor assembly must be replaced as a unit. See Spring Motor Selection Chart below for proper spring motor selection.

4.6.3 Disconnect all electrical power to the reel before beginning any maintenance or service.

4.6.4 Remove the slip ring and feeder cord from the reel by following the procedure in Section 4.4.

4.6.5 Remove the watertight and coupling from the shaft.

4.6.6 Remove the spring motor by unscrewing the shaft from the mounting base.

4.6.7 Re-assemble spring reel in reverse order with the new spring motor. Note the following:

- A Shaft must be fully seated on base before installing coupling and watertight.
- B Verify drum, slip ring and ratchet teeth orientation is per Figure 2, Page 9.

4.6.8 Adjust spring tension by following the procedure in Section 2.7.

### 4.6.9 Spring Motor Selection Chart

Spring Motor Selection Chart		
Cable Type	Cable Lengths That Use This Spring Motor	Spring Motor Part Number (Spring)
16/3 SJOW-A	Up to 50'	41028 (G50)
14/3 SJOW-A	Up to 50'	41028 (G50)
12/3 SJOW-A	Up to 50'	41027 (K50)
16/4 SJOW-A	Up to 50'	41028 (G50)
14/4 SJOW-A	Up to 50'	41028 (G50)
12/4 SJOW-A	Up to 40'	41027 (K50)
16/3 SOW-A	Up to 50'	41028 (G50)
14/3 SOW-A	Up to 40'	41027 (K50)
12/3 SOW-A	Up to 30'	41027 (K50)
16/4 SOW-A	Up to 50'	41027 (K50)
14/4 SOW-A	Up to 35'	41027 (K50)
12/4 SOW-A	Up to 25'	41027 (K50)
Sample: G=PPG160450-HSR      K= PPK160450-HSR		

## 5.0 Troubleshooting

PROBLEM	POSSIBLE CAUSE	SOLUTION
Reel with no retract cable but has some tension.	1) Improper pretension	1) See tension adjustment section.
	2) Incorrect reel for application (lift vs. stretch).	2) Quantify application vs. reel selection.
	3) Improper cable or cable length installed.	3) Install correct cable type and length.
	4) Cable guide adjustment	4) Check guide alignment
Reel does not have spring tension	1) Broken spring. *Quantify application to prevent reoccurrence.	1) Replace spring motor.
Ratchet will not engage	1) Broken ratchet pawl spring 2) Lock-out option arm disengaged.	1) Replace ratchet pawl spring. 2) Engage lock-out arm.
Ratchet will not disengage	1) Over-extension of reel.	1) Manually rotate reel spool to disengage ratchet. Do not over-extend. (Guide adjustment may prevent lock-up when over-extended.) 2) Adjust ball stop
Cable wraps improperly (uneven wrapping, wraps above or jumps flange.)	1) Reel mounting not level. 2) Cable retraction rate too high. 3) Cable guide out of adjustment. 4) Improper cable or cable length installed.	1) Mount reel on level surface. 2) Maintain steady retraction rate. 3) Properly adjust cable guide. 4) Install correct cable type and length.
Cable twisting or knotting.	1) Improperly installed cable.	1) See cable installation section in IOM.
	2) Cable rubbing on or bending around fixed object.	2) Check roller guide for function and cable pay out path.
	3) Excessive spring tension.	3) Quantify application vs. reel selection. Also check pretension
	4) Inadequate anchoring of cable.	4) Adjust anchoring method. i.e. add strain relief.
Open or intermittent circuit.	1) Inadequate connection.	1) Check all termination points.
	2) Loss of brush contact to slip ring.	2) Check brush wear, spring tension and alignment.
	3) Cable defective.	3) Perform continuity check on cable termination points.
Circuit trips and/or Pitted burned rings or brushes	1) Inadequate amp rating of reel selection.	1) Quantify application requirements vs. reel & cable rating.
Circuit arcing	1) Amp or voltage above rating of reel.	1) Quantify application requirements vs. reel & cable rating.
	2) Excessive carbon dust accumulation.	2) Clean dust from inside slip ring.
	3) Water or moisture in slip ring.	3) Check gasket seal.
	4) Loss of brush to ring contact.	4) Replace brush spring.

# 6.0 Replacement Parts

POWEEEL Catalog Number: \_\_\_\_\_

Description: \_\_\_\_\_

See Diagram of Page 16.

## 6.1 Part Descriptions

- 2 P/N 41012 Roller Guide Arm Ass'y
  - 3 P/N PR47-H Shaft Coupling
  - 7 P/N 41013 Outer Drum Gasket
  - 11 P/N 41005 Spool Drum
  - 12 P/N 41023 Inner Drum Gasket
  - 13 P/N 41003 Outer Flange
  - 14 P/N 08051 Flange Screws
  - 17 P/N 10171 Lock Washer
- 1200 Series

Cable/Feeder Cord w/o Plug (Per Ft.)	
P/N	SOW 3 & 4 Cond/SJOW 4 Cond
34750	16/3 SJOW-A Cable (0.31 OD)
34752	14/3 SJOW-A Cable (0.39 OD)
34754	12/3 SJOW-A Cable (0.47 OD)
34751	16/4 SJOW-A Cable (0.39 OD)
34753	14/4 SJOW-A Cable (0.42 OD)
34755	12/4 SJOW-A Cable (0.52 OD)
33018	16/3 SOW-A Cable (0.41 OD)
33030	14/3 SOW-A Cable (0.56 OD)
33042	12/3 SOW-A Cable (0.64 OD)
33019	16/4 SOW-A Cable (0.45 OD)
33031	14/4 SOW-A Cable (0.60 OD)
33043	12/4 SOW-A Cable (0.65 OD)

3= 600 Volt SOW-A or SOOW-A  
3= 300 Volt SJOW-A or SJOOW-A

Accessories		
Hand Lamp		
Item	Part No.	Description
HSR	HSR	Incandescent w/switch & outlet
FHL	FHL	Florescent handlamp w/ switch
Receptacle Box Assembly		
Item	Part No.	Description
RB1	RB	15 amp, 4 Outlet
RB2	RB-5-20R	20 amp, 4 Outlet
RB3	100467	20 amp, 2 Outlet w/ GFCI
RB4	35995	15 amp, 2 Outlet w/ GFCI

Installed Cable  
Blank = No Cable Installed  
## = Length of Cable (Ft.)  
00 to 50 Ft.  
\*Add 2 Ft. for Hookup

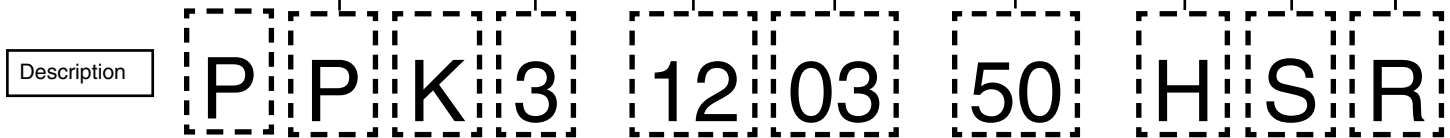

- 6 K= P/N 41027 K50 Spring Motor Ass'y  
G= P/N 41028 G50 Spring Motor Ass'y
- \* For reels manufactured prior to 2006 use P/N: 50863 for K50 Spring Motor and P/N: 50864 for G50 Spring Motor

- 4 P/N 41022 Base Ass'y & Ratchet Pawl Kit

- 5 P/N PR91 Ratchet Pawl Kit

Ball Stop Assembly	
Part No.	Description
34885	Cable OD Ranges (0.188-0.438)
34474	Cable OD Ranges (0.438-0.624)
34475	Cable OD Ranges (0.624-0.749)

Wire Gauge

Watertight Kit (Includes Cable-Tie)	
Part No.	Description
34955	Universal Cable Range (0.25-0.65)
34846	16 Gauge, 3 Conductor SJOW
03652	Cable Range (0.350-0.450)
03653	Cable Range (0.450-0.560)
04257	Cable Range (0.560-0.650)

Feeder Cord w/ Plug Assembly	
Part No.	Description
41042	6'-14/3 SJOW-A w/ 15 amp Plug
41043	6'-12/3 SJOW-A w/ 20 amp Plug

Number of Conductors

Slip Ring Assembly	
Part No.	Description
50804	3 Cond-30 amp
39565	4 Cond-30 amp

\* For reels manufactured prior to 2006 use P/N: 50863 for 3 & 4 cond. with K50 Spring and P/N: 50864 for 3 & 4 cond. with G50 spring.

- 9 P/N: 50865 Single Brush Replacement Kit

● For reels manufactured prior to 2006 use P/N: 41044 Brush Replacement Kit

# 6.0 Replacement Parts

## 6.2 Exploded View 1200 Series Cable Reel

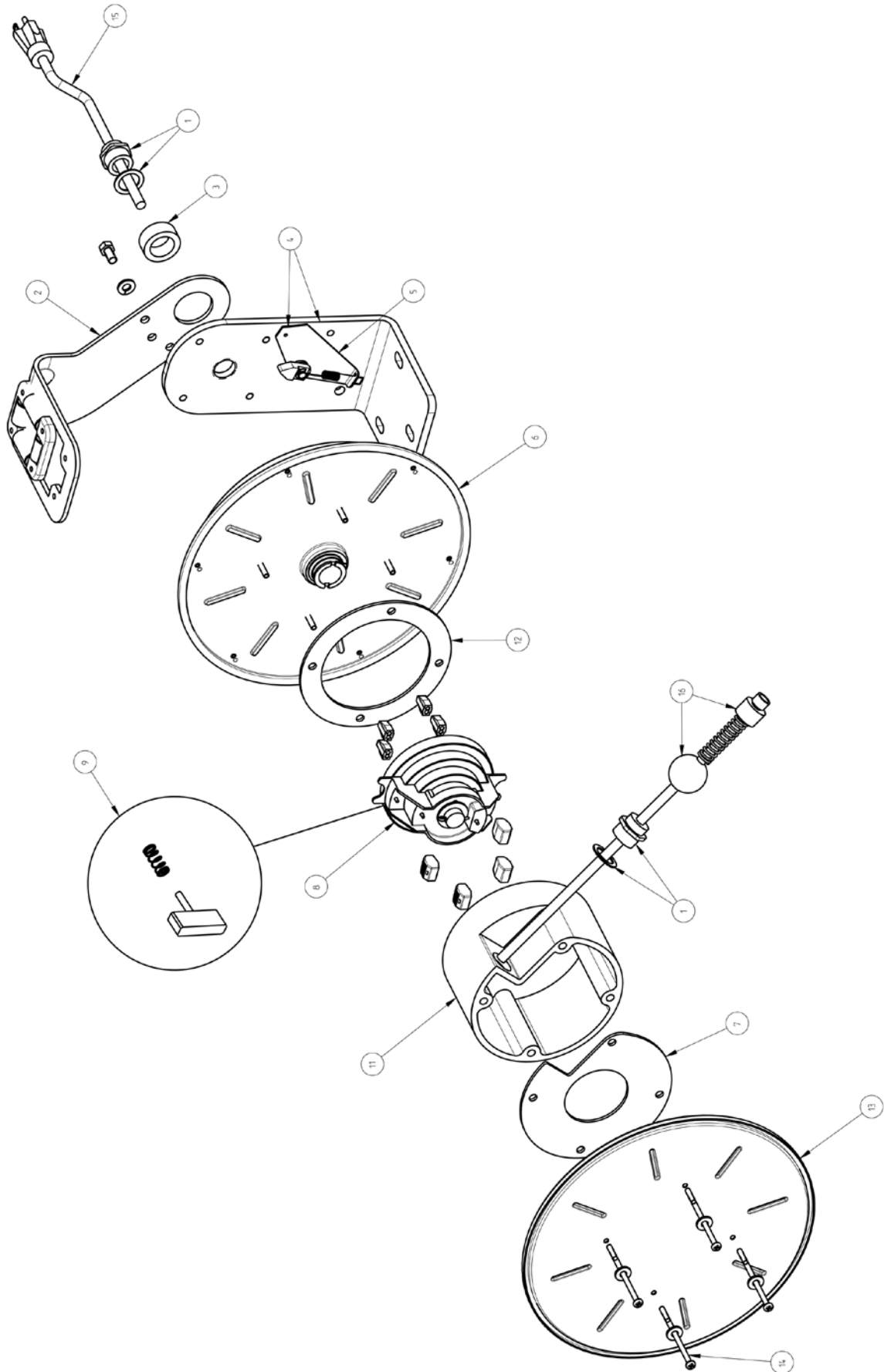

## Notes

# Notes

[www.conductix.com](http://www.conductix.com)

**Conductix-Wampfler**

10102 F Street  
Omaha, NE 68127  
USA

Customer Support

Phone: 800 521 4888

Fax: 800 780 8329

Phone: 402 339 9300

Fax: 402 339 9627

[info.us@conductix.com](mailto:info.us@conductix.com)

[www.conductix.com](http://www.conductix.com)

