

Repair Parts

Hoists that have been in service for a long period or under adverse conditions may require disassembly for adjustment and replacement of parts. The drawings on the following pages are of the exploded type to indicate order of assembly and relative position of parts. The parts list opposite each drawing includes a key number for each part. These key numbers appear on each drawing connected to the appropriate parts

Contents: no.	Page
1. Hoist Arrangement	24-25
2. Brake Components	26-27
3. Motor Components	28-29
4. Gearing Components	30-31
5. Liftwheel and Suspension components	32-33
6. Two Ton Plain and Geared Trolley	34-35
7. 2 Ton MDT, 3-7 1/2 Ton Trolley	36-37
8. 2 thru 7 1/2 Ton MDT Motor and Gearbox	38
9. Hoist Air Motor	39

Important

When referring to your hoist in correspondence or repair kit part orders, always give the model number from the hoist identification plate and the serial number which is stamped on the motor housing directly below

Part Number for Packaged Lubricants Used in the XL Air Chain Hoist (Refer to page 14 for Lubrication Instructions)		
Lubricant Usage	Type of Lubricant	Part Numbers and Packaged Quantity of Lubricants
Hoist Gears	Hulbest EP ISO VG 68 thru 460 (H-2)	52776 for 1 Gal. Can
Splines	*Grease	EP Type Grease - Obtain Locally
Load Chain	Oil	28608 for 1 Pint Can 28619 for 1 Gal. Can
Lower Hook Thrust Bearing	*Oil	Heavy Machine Oil Obtain Locally
Trolley Trackwheel Bearings and Gears	Grease (Novatex #2)	28632 for 4 lb. Can 28610 for 1 lb. Can
Trolley Gears	Grease (Novatex #1)	28613 for 4 lb. Can 28612 for 1 lb. Can

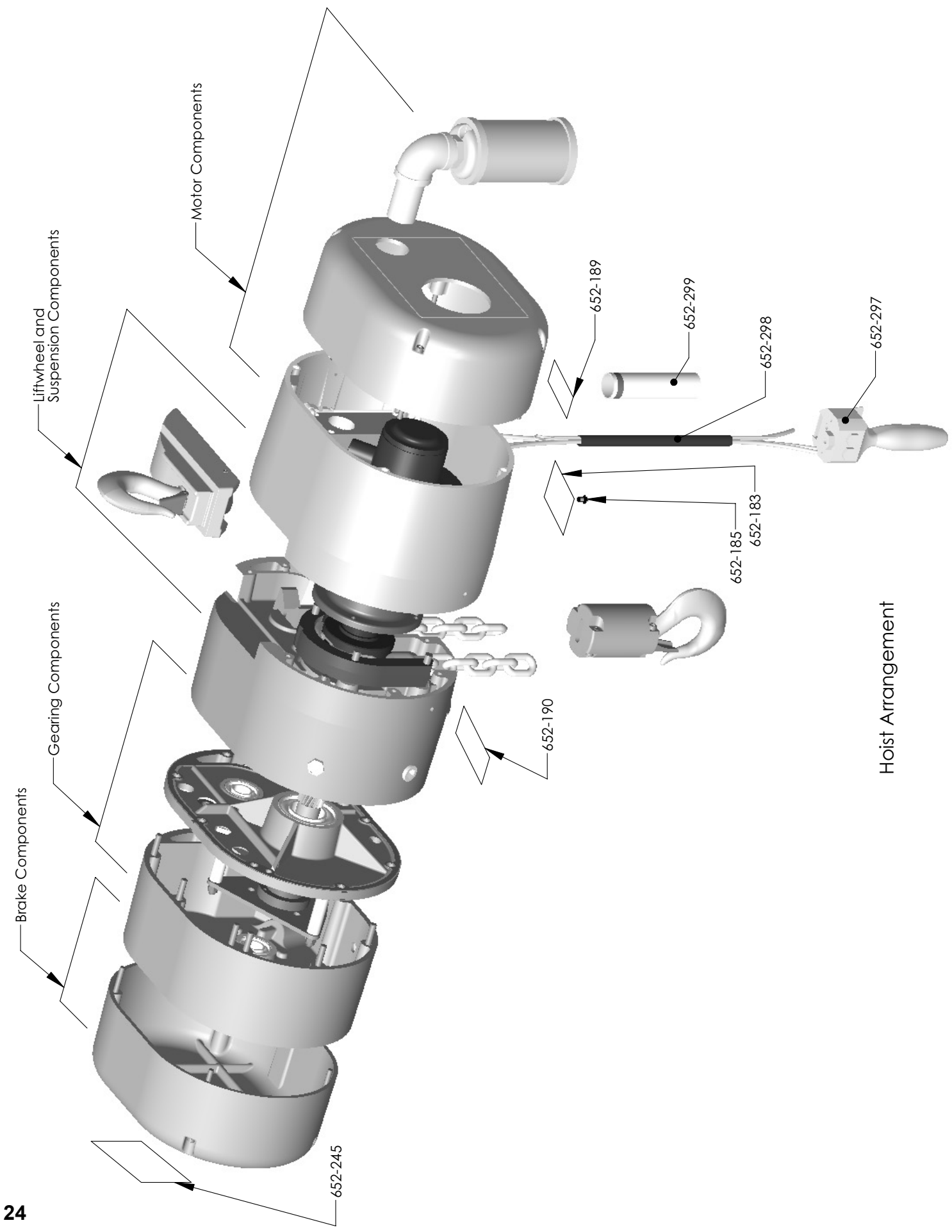

Hoist Arrangement

Key No.	No. Req'd	Part Name	Part No.
652-183	1	Identification Plate Lodestar XL Budgit XL Coffing XL	70728 70736 53035
652-185	4	I.D. Plate Drive Screw	988271
652-189	1	Capacity Label 2 Ton 3 Ton 5 Ton 6 Ton 7 1/2 Ton	52714 52724 52726 52728 52757
652-190	1	Warning Label 2 Ton 3 Ton 5 Ton 6 Ton 7 1/2 Ton	52715 52725 52726 52728 52785
652-245	1	Lodestar XL Label Budgit XL Label Coffing XL Label	52760 52782 53036
652-297	1	Control Pendant without MDT (2 paddle) with MDT (4 paddle)	53020 22825502
652-298	1	Control Cable without MDT with MDT For 10' Lift. For other lifts contact CM	53025 53037
652-299	1	Warning Tube	687J6

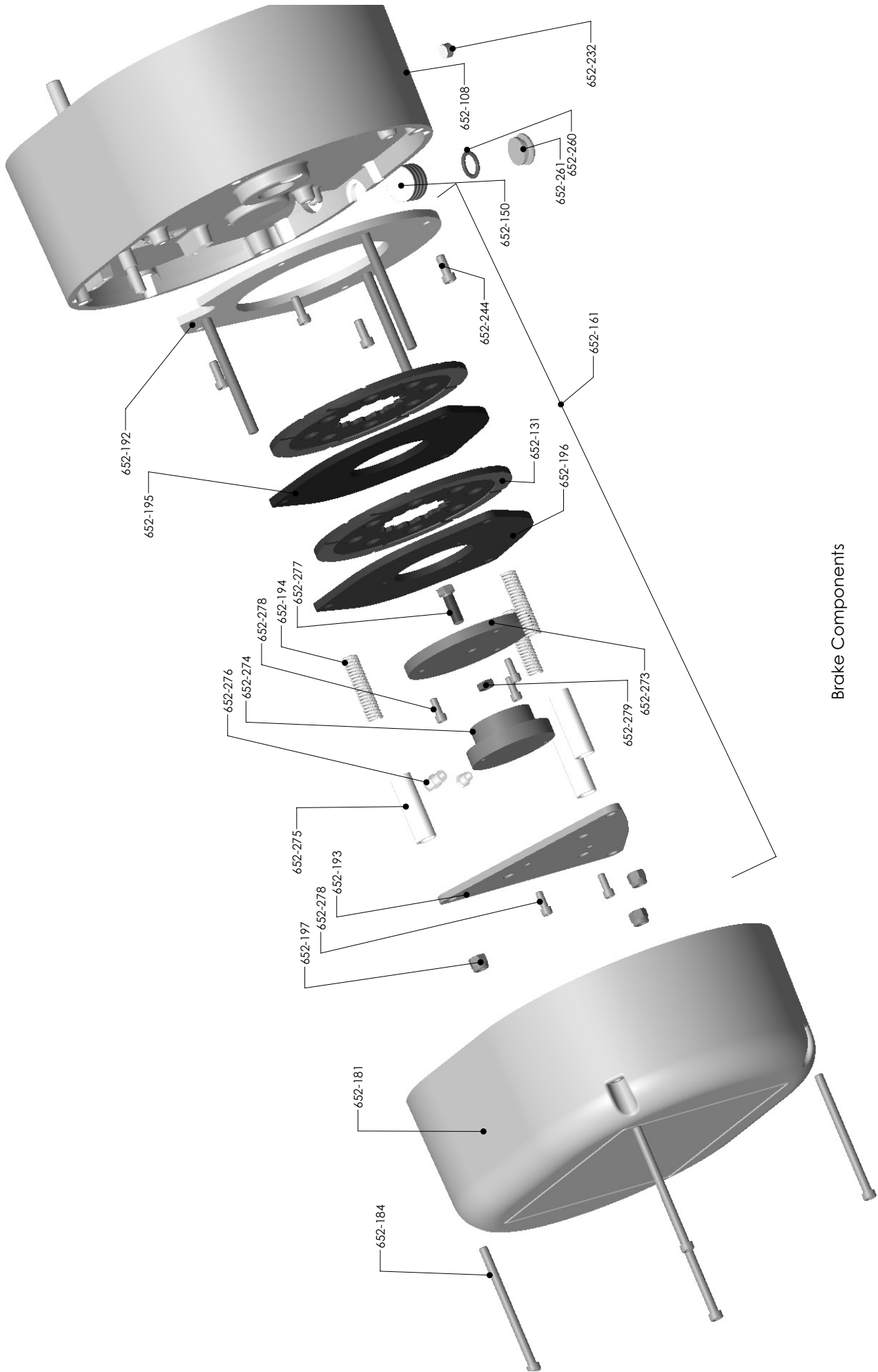

Brake Components

Brake Components

Key No.	No. Req'd	Part Name	Part No.
652-108	1	Brake Housing Assembly	52632
652-131	2	Brake Friction Disc	70652
652-150	1	Frame Plug (1")	989074
652-161	1	Air Brake Complete	53026
652-181	1	Brake End Cover	52028
652-184	4	Brake End Cover Screw	80409
652-192	1	Brake Base Plate	52607
652-193	1	Brake Field Plate	53008
652-194	1	Brake Spring Kit (3 springs total for brake assembly)	53044
652-195	1	Brake Intermediate Plate	68820
652-196	1	Brake Armature Plate	53007
652-197	3	Brake Nut	982448
652-232	1	Drain Plug	989050
652-244	4	Brake Attaching Screw	946801
652-260	1	Control Grommet O-Ring	52778
652-261	1	Control Grommet	52777
652-273	1	Brake Retaining Plate	53004
652-274	1	Air Cylinder	53005
652-275	3	Brake Spacer Tube	53006
652-276	1	Breather, Brake	53011
652-277	1	Screw, Brake	53029
652-278	5	Screw, Brake Air Cylinder Att'g	53017
652-279	1	Nut Brake Piston	988230

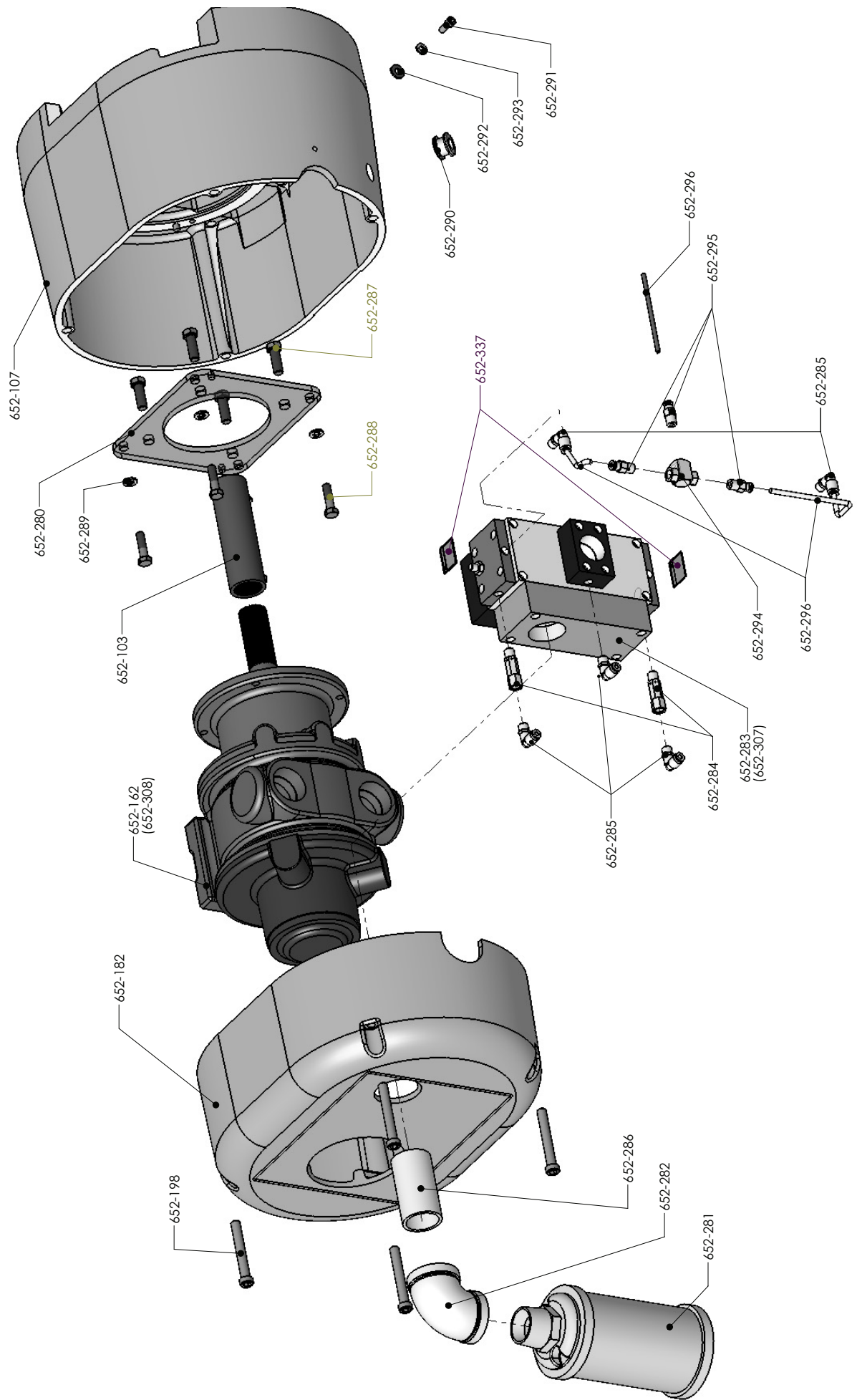

Motor Components

Key Number	No. Req'd	Part Name	Part Number
652-103	1	Motor Shaft Coupling	52078
652-107	1	Motor Housing Assembly	53019
652-162	1	Air Motor	53002
652-182	1	Motor End Cover	53012
652-198	4	Motor Cover Screw	80409
652-280	1	Motor Adapter Plate	53009
652-281	1	Muffler	53014
652-282	1	Muffler Connecting Elbow	53027
652-283	1	Bi-Directional Valve	53003
652-284	2	Quick Exhaust Valve	53016
652-285	5	Fitting, Male 90 Deg. Elbow	53021
652-286	1	1 1/4 Pipe Nipple Galvanized	53028
652-287	4	Motor Screw	982597
652-288	4	Motor Plate Screw	987210
652-289	4	Motor Plate Lockwasher	945851
652-290	1	Grommet	53013
652-291	1	Strain Loop Screw	53017
652-292	1	Strain Loop Washer	927835
652-293	1	Strain Loop Lockwasher	982226
652-294	1	Shuttle Valve	53015
652-295	3	Fitting, Straight	53018
652-296	A/R	3/16 Nylon Tubing	53023
652-307	1	Valve O-ring Repair Kit	53033
652-308	1	Motor Repair Kit (See page 39)	53034
652-337	2	Warning Label, Spool Stop	53043

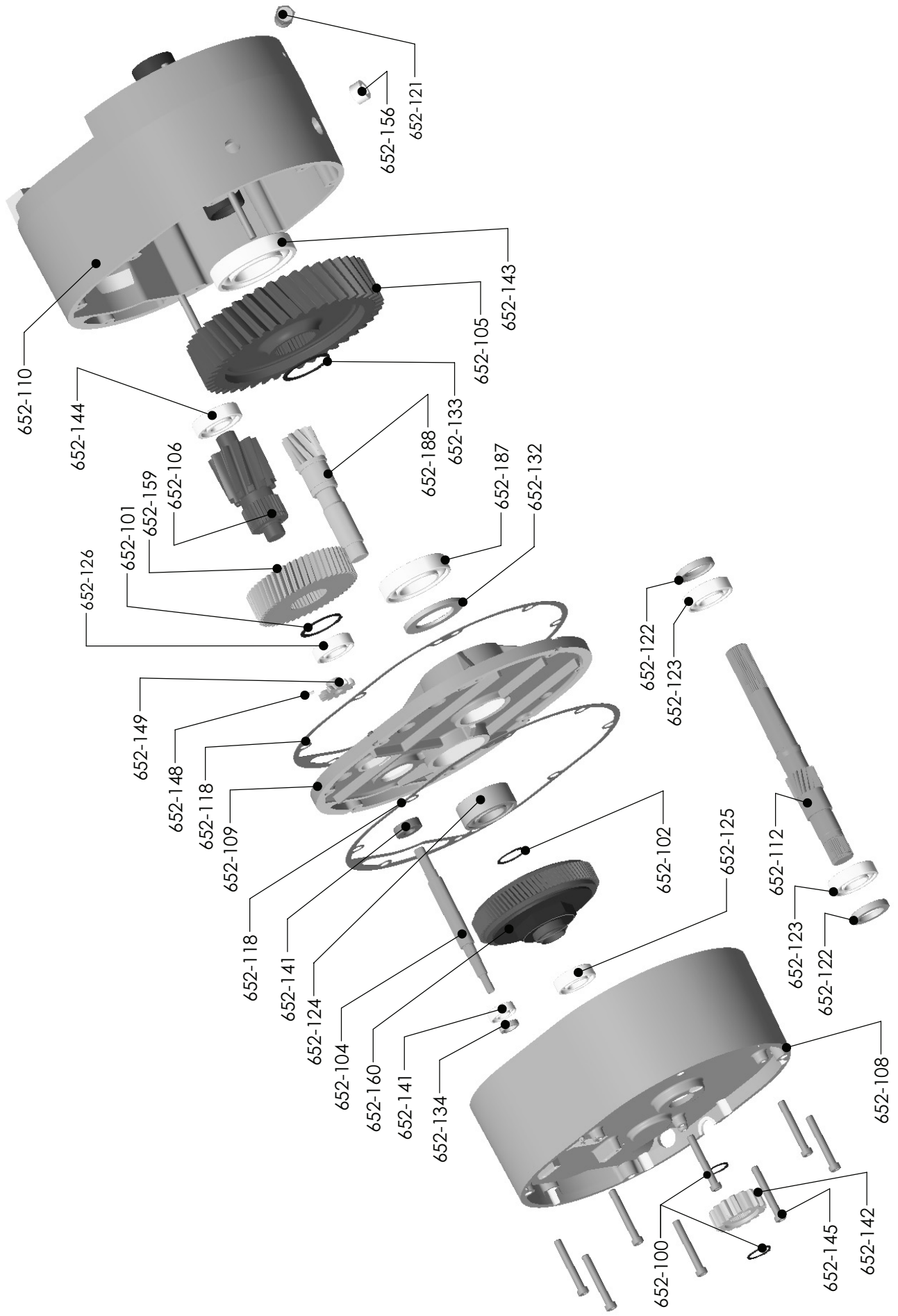

Gearing Components

Key No.	No. Req'd	Part Name	Part Number
652-100	2	Brake Hub Snap Ring	35764
652-101	1	2nd Gear Snap Ring	36763
652-102	1	2nd Pinion Snap Ring	45766
652-104	1	Limit Switch Input Shaft	52019
652-105	1	Liftwheel Gear	52021
652-106	1	3rd Reduction Pinion and Shaft	52026
652-108	1	Brake Housing Assembly	52632
652-109	1	Intermediate Plate Assembly	52633
652-110	1	Main Housing Assembly	52630
652-112	1	Drive Shaft and Pinion	52079
652-118	2	Main Housing Gasket	52709
652-121	1	Breather	70726
652-122	2	Drive Shaft Seal	80401
652-123	2	Drive Shaft Bearing	80402
652-124	1	2nd Reduction Pinion Bearing - Inboard	80403
652-125	1	2nd Reduction Pinion Bearing- Outboard	80404
652-126	1	3rd Reduction Pinion Bearing - Outboard	80408
652-132	1	Liftwheel Seal - Inboard	80415
652-133	1	Liftwheel Gear Snap Ring	80416
652-134	1	Limit Switch Input Shaft Seal	80417
652-141	2	Limit Switch Input Shaft Bearing	88437
652-142	1	Brake Hub	68367
652-143	1	Liftwheel Bearing-Gear End	80413
652-144	1	3rd Reduction Pinion Bearing- Inboard	88500
652-145	15	Frame Screw	987289
652-148	1	Limit Switch Gear Pin	983768
652-149	1	Limit Switch Gear	52713
652-156	2	Frame Plug (3/4")	989055
652-159	1	2nd Gear	52024
652-160	1	Protector Assembly 2 Ton, 6 Ton 3 Ton 5 ton, 7.5 Ton	52614 52613 52616
652-187	1	Liftwheel Gear Bearing	80414
652-188	1	2nd Reduction Pinion	52023

Liftwheel and Suspension

Key No.	No. Req'd	Part Name	Part Number
652-107	1	Motor Housing Assembly	53019
652-110	1	Main Housing Assembly	52630
652-111	1	Liftwheel	52033
652-113	1	Chain Guide	52041
652-114	1	Chain Stripper	52055
652-127	3	Chain Guide Pin	80410
652-128	1	Liftwheel Bearing - Motor End	80411
652-129	1	Liftwheel Seal - Gear End	80412
652-163	1	Load Chain	85885
652-175	1	Lower Hook with Latch: Latch Type: 2 Ton 3,5,6 and 7 1/2 Ton	35612 52651
652-176	1	Lower Hook - Loatchlok Type 2 Ton 3,5, and 6 Ton 3-6 Ton Lower Latchlok Kit	36681 52625 5264
652-177	2	Half Link	52017
652-178	2	Hook Block: 2 Ton 3 and 5 Ton 6 and 7 1/2 Ton	52025 52049 52069
652-179	1	Chain Plate: 2 Ton 3 and 4 Ton	52046 52048
652-180	2	Hook Block Screw: 2 Tond 3 and 5 Ton 6 and 7 1/2 Ton	982369 80423 80423
652-187	2	Chain Plate or Idler Housing Screw	987288
652-200	1	Liftwheel Gear Bearing	80414
652-201	1	Hook Nut or Collar for: 2 Ton 3,5,6 and 7 1/2 Ton	35369 52047
652-202	1	Hook Nut or Collar Pin for: 2 Ton 3, 5, 6 and 7 1/2 Ton	45946 80418
652-203	1	Lower Hook Thrust Bearing for: 2 Ton 3, 5, 6 and 7 1/2 Ton	88505 80421
652-204	1	Sheave Wheel	52050
652-205	1	Dead End Block	52051
652-206	2	Dead End Pin	52057
		Sheave Wheel Bearing	80422

Key No.	No. Req'd	Part Name	Part Number
652-207	1	Dead End Bolt: 3, 5, 6 and 7 1/2 Ton	80424
652-210	1	Dead End Plate	52068
652-211	1	Idler Wheel Housing	52053
652-212	1	Idler Wheel	52054
652-213	1	Anchor Pin	52058
652-214	2	Idler Wheel Bearing	80425
652-215	6	Dead End Plate Screw	52074
652-216	1	Latch Kit for: 2 Ton 3, 5, 6 and 7 1/2 Ton	45663 52701
652-217	1	Suspension Adapter for: 2 Ton 3,5, and 6 Ton	52022 52035
652-218	1	Upper Hook Nut for: 2 Ton 3,5, and 6 Ton	52045 52047
652-220	1	Upper Hook, Latch Type for: 2 Ton 3,5, 6 and 7 1/2 Ton	52608 52651
652-221	1	Upper Hook, Latchlok Type for: 2 Ton 3, 5, and 6 Ton	52624 52625
652-222	1	Hook Nut Pin	80418
652-224	1	Anti-Rotation Pin for: 2 Ton 3, 5, and 6 Ton	80419 80420
652-225	1	Suspension Screw (2Ton Only)	987208
652-226	1	Anti-Rotation Plate	52708
652-227	1	Anti-Rotation Plate Screw	982371
652-253	1	Upper Hook Suspension Latch Type Complete 2 Ton 3, 5, and 6 Ton	5254 5255
652-256	1	Dead End Block Spacer	52064
652-257	1	Loose End Screw	982667
652-258	1	Loose End Screw Washer	987898
652-304	1	Loose End Screw Washer	45915
652-305	1	Dead End Stop	53030
652-306	1	Dead End Stop Screw	982066
652-337	1	Dead End Stop Screw Locking Nut	82638
652-338	1	Snubber Plate	53052
		Snubber Black Assembly	53053

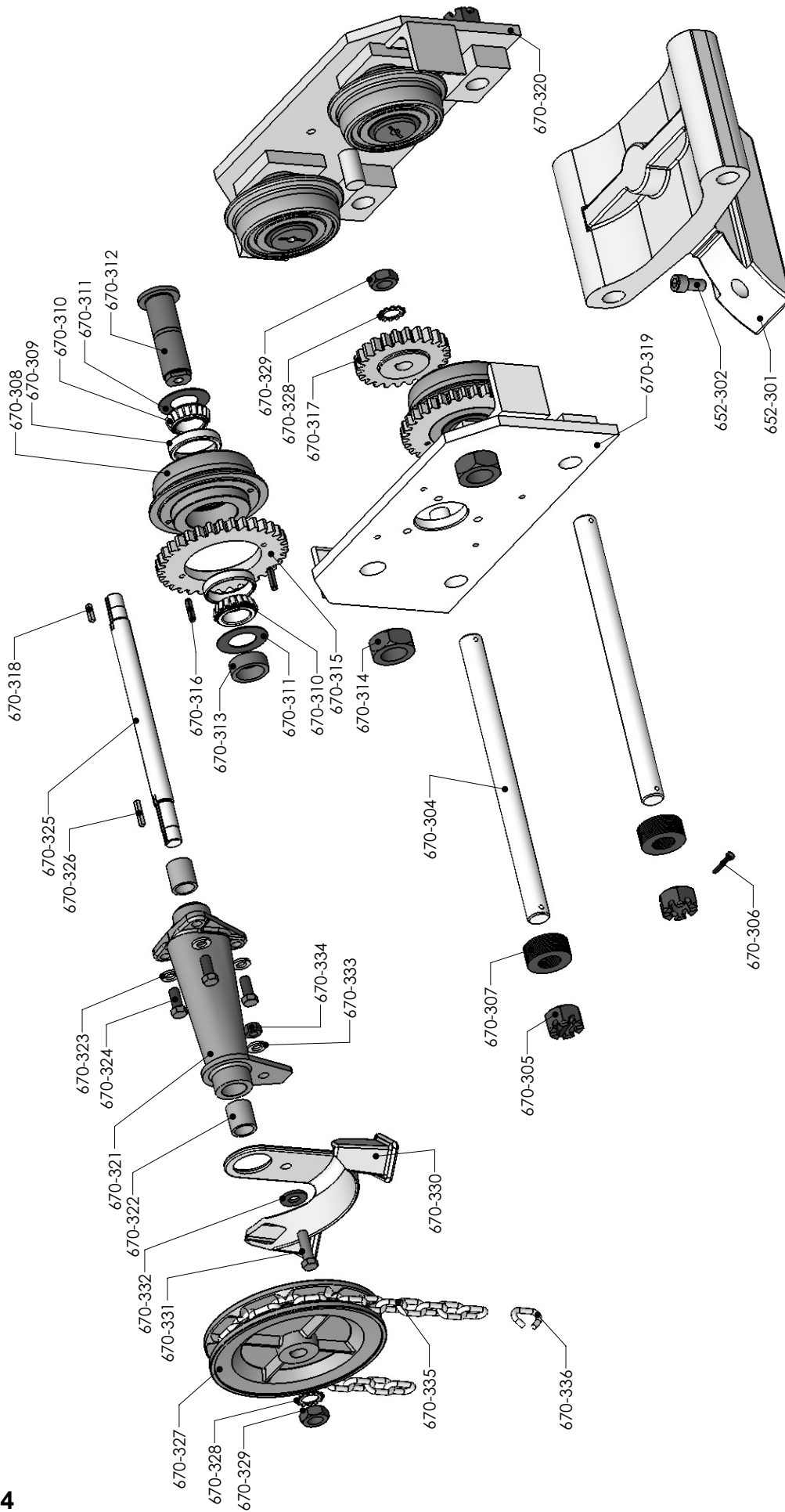

2 TON
PLAIN AND GEARED TROLLEYS
EXPLODED VIEW

**2 Ton
Plain and Geared Trolleys Parts List**

Key No.	No. Req'd	Part Name	Part Number
652-301	1	Hoist Suspension Adapter	52059
652-302	1	Suspension Adapter Screw/Dead End Bolt	987208
670-304	2	Suspension Bolt	58503
670-305	4	Suspension Bolt Nut	958818
670-306	4	Suspension Bolt Nut Cotter Pin	988368
670-307	-	Spacer Washer-Specify No. Req'd	958726
670-308	4	Trackwheel with Bearing Cup	
670-309	8	Trackwheel Bearing Cup	88521
670-310	8	Trackwheel Bearing Cone	88525
670-311	4	Trackwheel Bearing Shield	88525
670-312	4	Trackwheel Stud	68918
670-313	4	Trackwheel Stud Collar	58459
670-314	4	Trackwheel Stud Nut	58484
670-315	2	Trackwheel Gear	982613
670-316	4	Trackwheel Gear Pin	983503
670-317	1	Trackwheel Gear Pinion	58505
670-318	1	Trackwheel Pinion Key	85546
670-319	1	Geared Side Frame	59615

Key Nu.	No. Req'd	Part Name	Part Number
670-320		Plain Side Frame	59614
670-321	1	Handwheel Bracket with Bushings	59616
670-322	2	Handwheel Bushing	58727
670-323	3	Handwheel Bracket Screw L.W.	945853
670-324	3	Handwheel Bracket Screw	987061
670-325	1	Handwheel Shaft	59504
670-326	1	Handwheel Key	59967
670-327	1	Handwheel	33143
670-328	1 or 2	Trackwheel Pinion or Handwheel Shaft Nut L.W.	986270
670-329	1 or 2	Trackwheel Pinion or Handwheel Shaft Nut	988095
670-330	1	Handchain Guide	58152
670-331	1	Chain Guide Screw	987065
670-332	1	Chain Guide Screw Washer	986224
670-333	1	Chain Guide Screw L.W.	945853
670-334	1	Chain Guide Screw Nut	945822
670-335	-	Hand Chain-Specify length req'd	619022
670-336	1	Hand Chain Connecting Link	945491

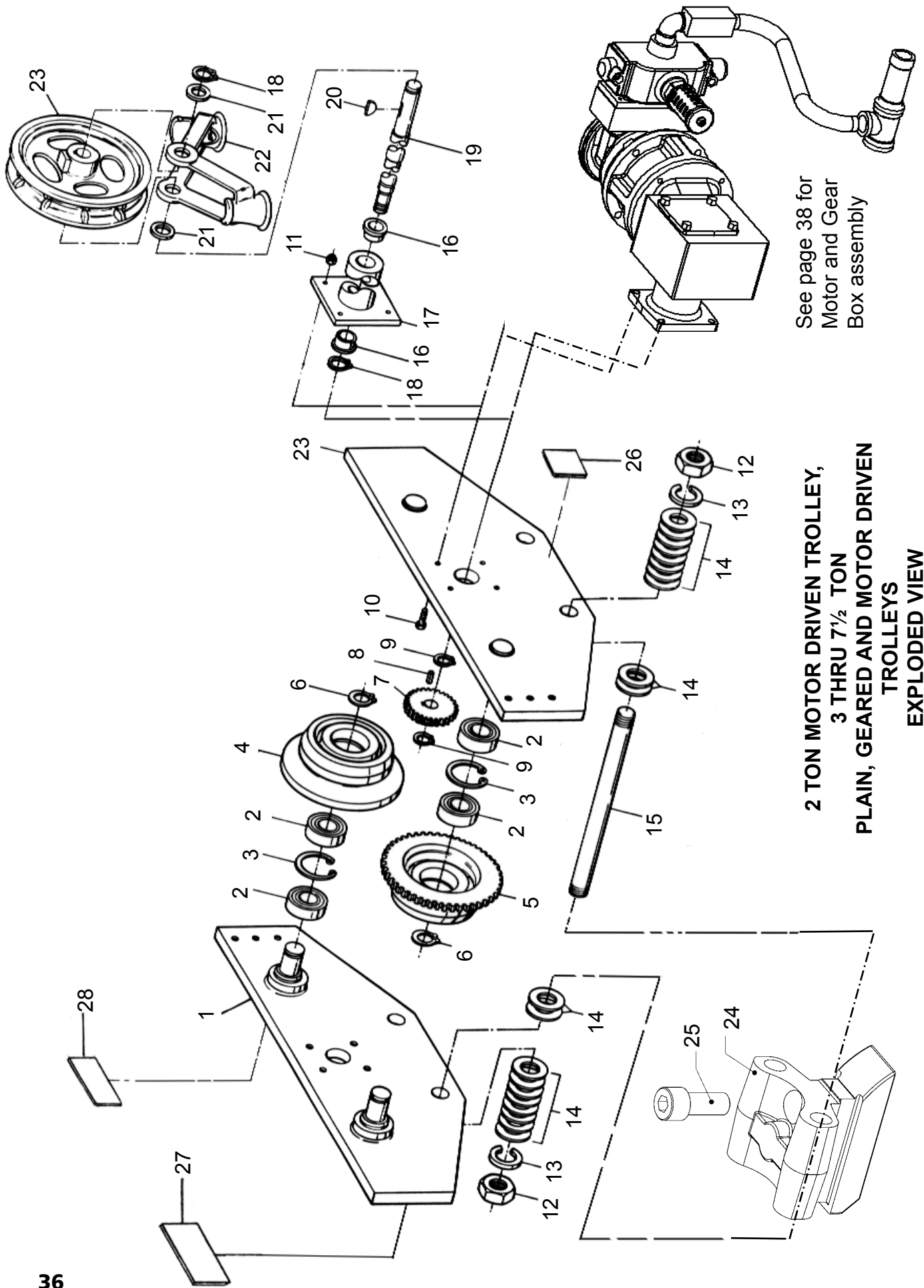

See page 38 for
Motor and Gear
Box assembly

**2 TON MOTOR DRIVEN TROLLEY,
3 THRU 7½ TON
PLAIN, GEARED AND MOTOR DRIVEN
TROLLEYS
EXPLODED VIEW**

REF. NO.	NO. REQ'D	PART DESCRIPTION	PART NUMBER					
			3 TON		2 & 3 TON	5 - 7 1/2 TON		
			PLAIN	GEARED	MOTOR DRIVEN	PLAIN	GEARED	MOTOR DRIVEN
1	2	SIDE PLATE ASSEMBLY FOR:						
		4" TO 6 1/4" FLG. AND PATENTED TRACK	700T-1400	700T-1700	BET-2800	700T-1501	700T-1801	BET-3801
		6 3/8" TO 8 5/8" FLG.	700T-1402	700T-1701	BET-2801	700T-1504	700T-1803	BET-3803
		8 3/4" TO 11" FLG.	700T-1404	700T-1702	BET-2802	700T-1507	700T-1805	BET-3805
2	8	BALL BEARING	700T-1406	700T-1703	BET-2803	700T-1514	700T-1811	BET-3811
3	4	RETAINING RING	700T-1407	700T-1704	BET-2804	700T-1516	700T-1813	BET-3813
4	2	TRACKWHEEL-PLAIN						
		STANDARD	700T-1408	700T-1705	BET-2805	700T-1518	700T-1815	BET-3815
		PATENTED TRACK	700T-1409	700T-1706	BET-2806	700T-1520	-----	BET-3817
		SPARK RESISTANT	700T-1410	700T-1707	-----	700T-1521	700T-1818	-----
5	2	TRACKWHEEL-GEARED						
		STANDARD	-----	700T-1708	BET-2807	-----	700T-1820	BET-3818
		PATENTED TRACK	-----	700T-1709	BET-2808	-----	-----	BET-3820
		SPARK RESISTANT	-----	700T-1710	-----	-----	700T-1823	-----
6	4	RETAINING RING	700T-1411	700T-1711	BET-2809	700T-1523	700T-1825	BET-3821
7	1	PINION	-----	700T-1719	BET-2810	-----	700T-1846	BET-3823
8	1	PINION KEY	-----	700T-1720	BET-2811	-----	700T-1847	BET-3824
9	2	**RETAINING RING	-----	700T-1718	BET-2812	-----	700T-1845	BET-3825
10	4	HEX CAP SCREW	-----	700T-1721	BET-2813	-----	700T-1848	BET-3826
11	4	SELF LOCKING NUT	-----	700T-1725	BET-2814	-----	700T-1853	BET-3828
12	4	HEX JAM NUT	700T-1412	700T-1712	BET-2815	700T-1526	700T-1828	BET-3830
13	4	LOCKWASHER	700T-1414	700T-1713	BET-2816	700T-1529	700T-1831	BET-3833
14	40	SPACE WASHERS	700T-1416	700T-1714	BET-2817	700T-1532	700T-1834	BET-3836
15	2	SUSPENSION PIN FOR:						
		4" TO 6 1/4" FLG. AND PATENTED TRACK	700T-1418	700T-1715	BET-2818	700T-1535	700T-1837	BET-3839
		6 3/8" TO 8 5/8" FLG.	700T-1420	700T-1716	BET-2819	700T-1537	700T-1839	BET-3841
		8 3/4" TO 11" FLG.	700T-1422	700T-1717	BET-2820	700T-1539	700T-1841	BET-3843
16	2	BUSHING	-----	700T-1723	-----	-----	700T-1851	-----
17	1	PLATE AND TUBE ASSEMBLY	-----	700T-1724	-----	-----	700T-1852	-----
18	2	RETAINING RING	-----	700T-1722	-----	-----	700T-1850	-----
19	1	HANDWHEEL SHAFT	-----	700T-1726	-----	-----	700T-1854	-----
20	1	HANDWHEEL SHAFT KEY	-----	700T-1727	-----	-----	700T-1856	-----
21	2	WASHER	-----	700T-1728	-----	-----	700T-1857	-----
22	2	CHAIN GUIDE						
		8 5/8" O.D. HAND CHAIN WHEEL	-----	700T-1729	-----	-----	-----	-----
		11 5/8" O.D. HAND CHAIN WHEEL	-----	700T-1730	-----	-----	700T-1858	-----
23	1	HAND CHAIN WHEEL						
		8 5/8" OUTSIDE DIAMETER	-----	700T-1731	-----	-----	-----	-----
		11 5/8" OUTSIDE DIAMETER	-----	700T-1732	-----	-----	700T-1860	-----
24	1	SUSPENSION ADAPTER	52784			52787		
25	1	SUSPENSION ADAPTER SCREW	80430			80430		
26	1	WARNING LABEL	-----	936986		-----	936986	
27	1	TROLLEY CAPACITY LABEL	52764			52765		
28	1	WARNING LABEL	936984			936984		
29***	AS REQ'D	HAND CHAIN (NOT SHOWN)						
		STANDARD	-----	700T-1733	-----	-----	700T-1862	-----
		SPARK RESISTANT	-----	700T-1734	-----	-----	700T-1863	-----
		OPEN LINK (1 REQUIRED)	-----	700T-1735	-----	-----	700T-1864	-----

* TOTAL QUANTITY OF 4 EACH REQUIRED FOR PLAIN TYPE TROLLEYS.

** TOTAL QUANTITY OF 1 EACH REQUIRED FOR 3 TON TROLLEYS.

*** SPECIFY LENGTH OF HAND CHAIN REQUIRED. STANDARD LENGTH EQUALS TWO TIMES HOIST LIFT PLUS 2'-6".

3 THRU 7½ TON MOTOR AND GEAR BOX ASSEMBLY

2 THRU 7 1/2 TON MOTOR AND GEAR BOX ASSEMBLY

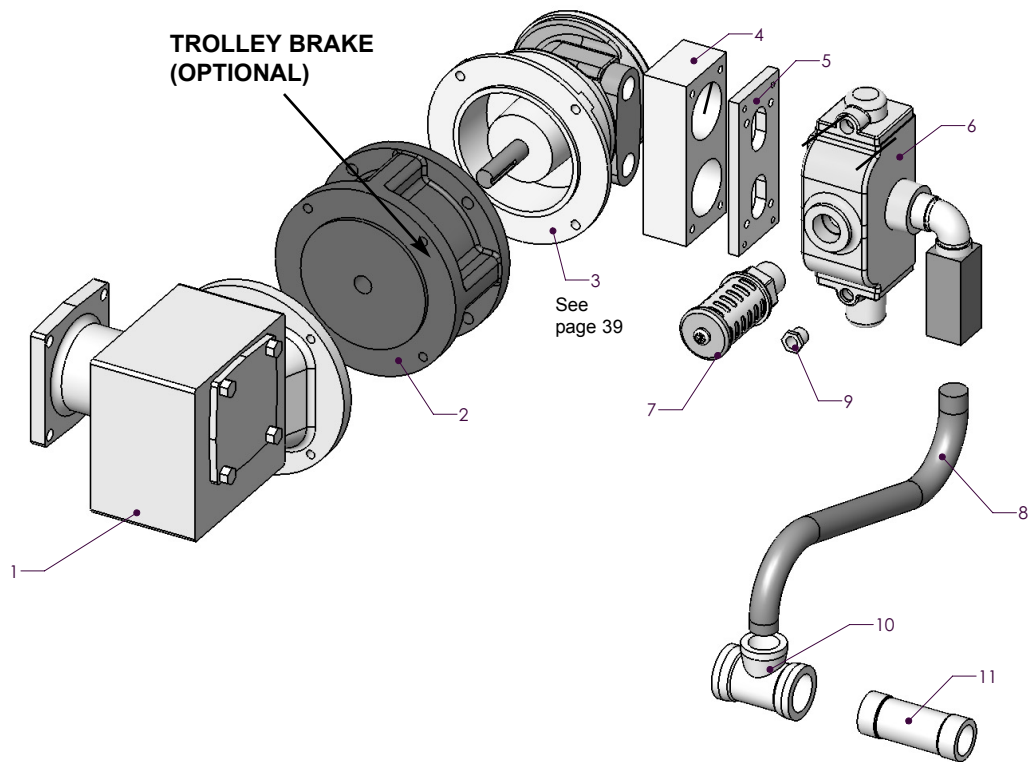

***SEE PAGE 39 FOR TROLLEY BRAKE ASSEMBLY**

Ref. No.	No. Req'd	Part Description	Part Number
1	1	Gear Box Assembly	BET-3003
2	1	Air Brake	Contact Factory
3	1	Air Motor	22721301
4	1	Mounting Plate	22925703
5	1	Sandwich Plate	22925501
6	1	Valve	22746302
7	1	Muffler	227472-1
8	1	Air Hose Assembly	53042
9	1	Hex Bushing	53039
10	1	Reducing Tee	53040
11	1	Pipe Nipple	53041
12 *	1	Gasket	11443301
13 *	1	Gasket	22746801

* Not Shown

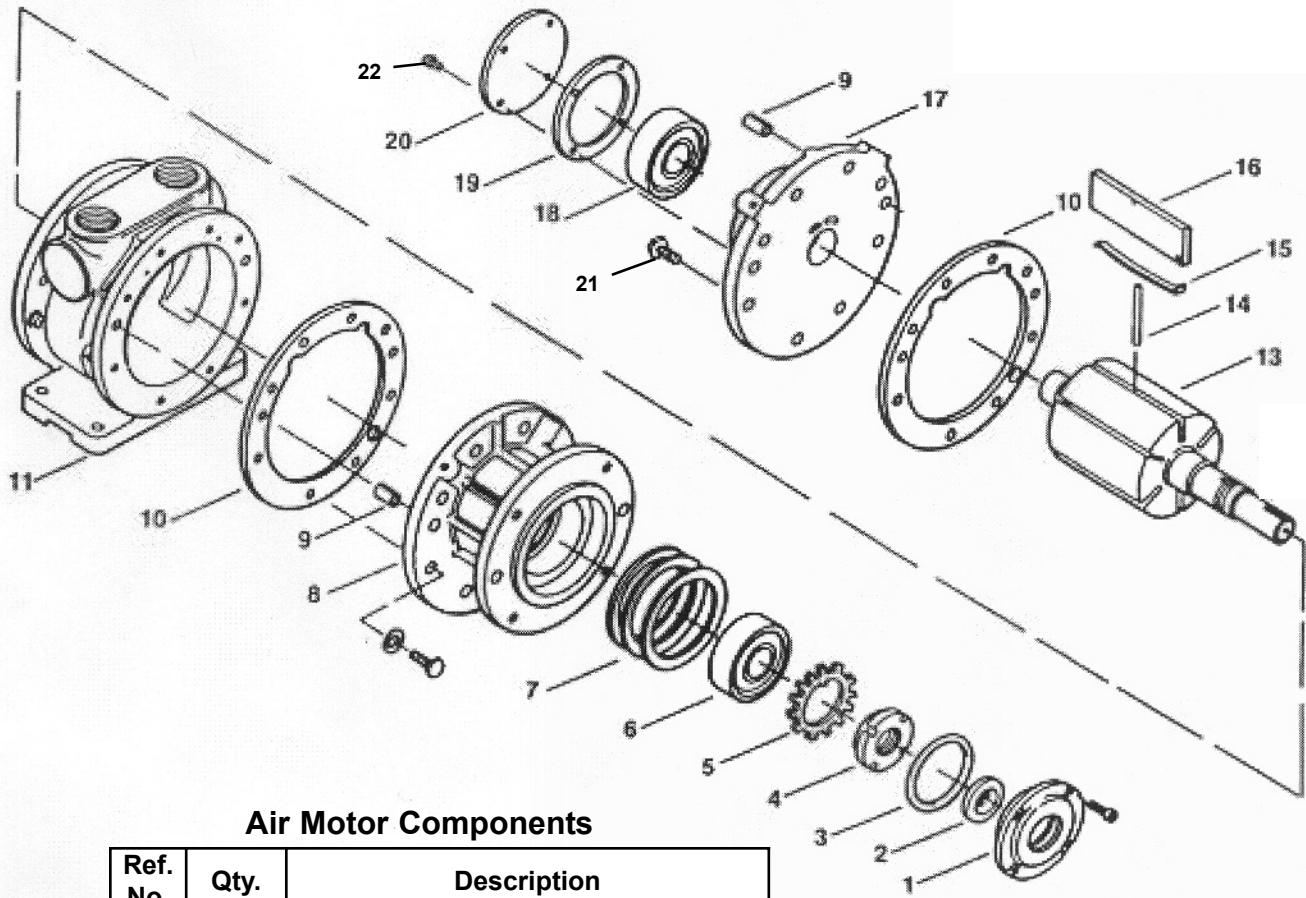

Air Motor Components

Ref. No.	Qty.	Description
1	1	Drive End Cap
2 *	1	Seal
3 *	1	O-Ring
4	1	Locknut
5 *	1	Lockwasher
6 *	1	Drive End Bearing
7	1	Spacer
8	1	Drive End Plate
9	4	Dowel Pin
10 *	2	Spacer Gasket
11	1	Body
13	3	Rotor Assembly
14 *	6	Push Pin
15 *	6	Vane Spring
16 *	1	Vane
17	1	Dead End Plate
18	1	Dead End Bearing
19	1	End Cap Gasket
20	1	Dead End Cap
21	4	Dead End Plate Bolts
22	4	Dead End Plate Cap Bolts
*	1	Service Kit 652-308 (order code 53034)

Note: Parts Identified with a star (*) are available only as part of service kit (code 53035). Remaining part numbers are not available for repair. Requires replacement with an air motor (code 53002).

Note: When ordering parts, always furnish Hoist Model and Serial Number, Motor Horsepower, Voltage, Phase, Frequency and Rated Capacity of hoist on which the parts are to be used.

For the location of the nearest Master Parts Depot, see the list located on the inside front cover.

LIMITATION OF WARRANTIES, REMEDIES AND DAMAGES

THE WARRANTY STATED BELOW IS GIVEN IN PLACE OF ALL OTHER WARRANTIES, EXPRESS OR IMPLIED, OF MERCHANTABILITY, FITNESS FOR A PARTICULAR PURPOSE, OR OTHERWISE, NO PROMISE OR AFFIRMATION OF FACT MADE BY ANY AGENT OR REPRESENTATIVE OF SELLER SHALL CONSTITUTE A WARRANTY BY SELLER OR GIVE RISE TO ANY LIABILITY OR OBLIGATION.

Seller warrants that on the date of delivery to carrier the goods are free from defects in workmanship and materials.

SELLER'S SOLE OBLIGATION IN THE EVENT OF BREACH OF WARRANTY OR CONTRACT OR FOR NEGLIGENCE OR OTHERWISE WITH RESPECT TO GOODS SOLD SHALL BE EXCLUSIVELY LIMITED TO REPAIR OR REPLACEMENT, F.O.B. SELLER'S POINT OF SHIPMENT, OF ANY PARTS WHICH SELLER DETERMINES TO HAVE BEEN DEFECTIVE or if Seller determines that such repair or replacement is not feasible, to a refund of the purchase price upon return of the goods to Seller.

Any action against Seller for breach of warranty, negligence or otherwise, must be commenced within one year after such cause of action accrues.

NO CLAIM AGAINST SELLER FOR ANY DEFECT IN THE GOODS SHALL BE VALID OR ENFORCEABLE UNLESS BUYER'S WRITTEN NOTICE THEREOF IS RECEIVED BY SELLER WITHIN ONE YEAR FROM THE DATE OF SHIPMENT.

Seller shall not be liable for any damage, injury or loss arising out of the use of the goods if, prior to such damage, injury or loss, such goods are (1) damaged or misused following Seller's

delivery to carrier; (2) not maintained, inspected, or used in compliance with applicable law and Seller's written instructions and recommendations; or (3) installed, repaired, altered or modified without compliance with such law, instructions or recommendations.

UNDER NO CIRCUMSTANCES SHALL SELLER BE LIABLE FOR INCIDENTAL OR CONSEQUENTIAL DAMAGES AS THOSE TERMS ARE DEFINED IN SECTION 2-715 OF THE UNIFORM COMMERCIAL CODE.

INDEMNIFICATION AND SAFE OPERATION

Buyer shall comply with and require its employees to comply with directions set forth in instructions and manuals furnished by Seller and shall use and require its employees to follow such instructions and manuals and to use reasonable care in the use and maintenance of the goods. Buyer shall not remove or permit anyone to remove any warning or instruction signs on the goods. In the event of personal injury or damage to property or business arising from the use of the goods, Buyer shall within 48 hours thereafter give Seller written notice of such injury or damage. Buyer shall cooperate with Seller in investigating any such injury or damage and in the defense of any claims arising therefrom.

If Buyer fails to comply with this section or if any injury or damage is caused, in whole or in part, by Buyer's failure to comply with applicable federal or state safety requirements, Buyer shall indemnify and hold Seller harmless against any claims, loss or expense for injury or damage arising from the use of the goods.

WARNING

Alterations or modifications of equipment and use of non-factory repair parts can lead to dangerous operation and injury.

TO AVOID INJURY:

- Do not alter or modify equipment
- Do use only factory provided replacement parts.



Columbus McKinnon Corporation
140 John James Audubon Parkway
Amherst, New York 14228-1197
Phone: (800) 888-0985
Fax: (716) 689-5644



Lift-Tech International
414 West Broadway Ave.
Muskegon, Michigan 49443-0769
Phone: (231) 733-0821
Fax: (800) 742-9270



Country Club Road
P.O. Box 779
Wadesboro, NC 28170 U.S.A.
Phone 800-477-5003
Fax (800) 374-6853