

# BUDGIT® Electric Hoist Wiring Diagrams

## 115/230 VOLT RECONNECTABLE, 1 PHASE, SINGLE SPEED HOIST

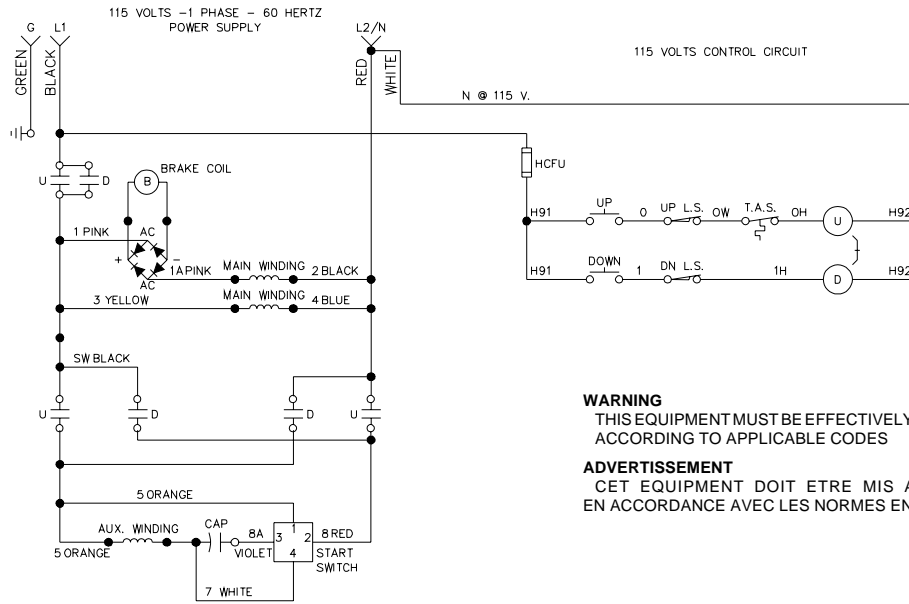

**WARNING**  
THIS EQUIPMENT MUST BE EFFECTIVELY GROUNDED  
ACCORDING TO APPLICABLE CODES

**ADVERTISSEMENT**  
CET EQUIPMENT DOIT ETRE MIS A'LA TERRE  
EN ACCORDANCE AVEC LES NORMES EN VIGUEUR.

333171-02

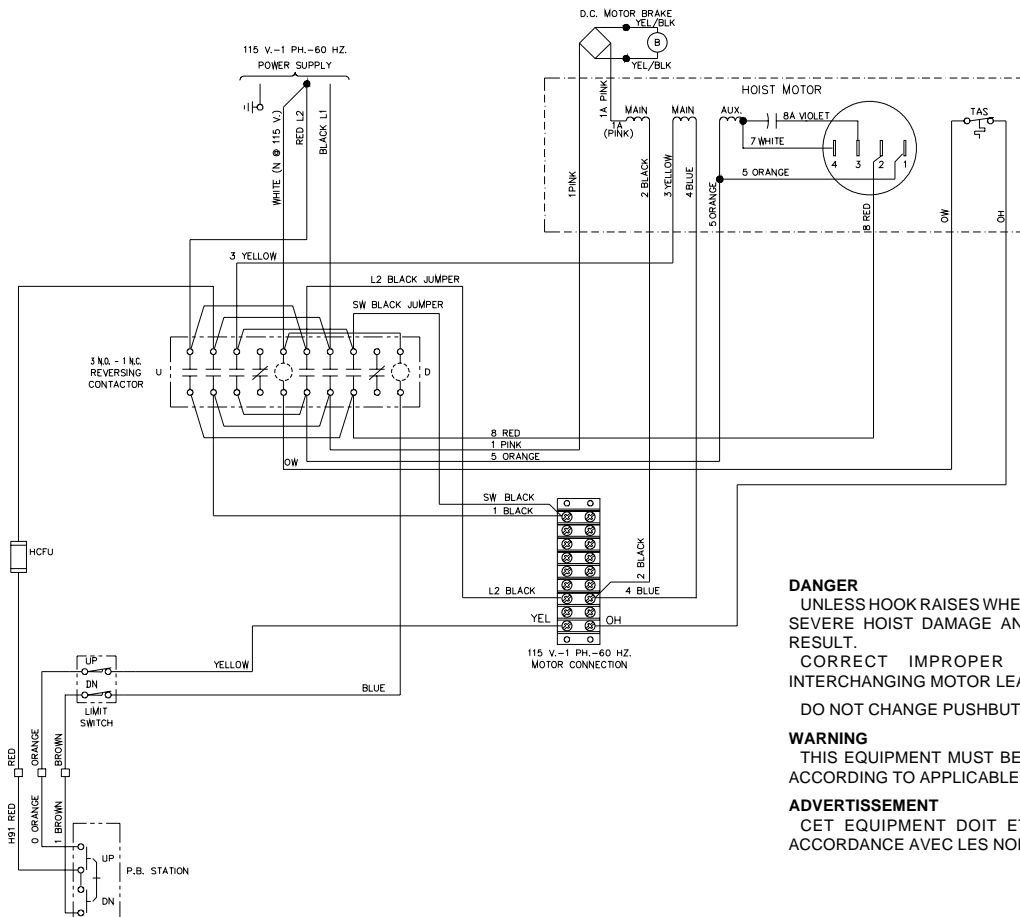

**DANGER**  
UNLESS HOOK RAISES WHEN "UP" BUTTON IS PRESSED  
SEVERE HOIST DAMAGE AND A DROPPED LOAD MAY  
RESULT.  
CORRECT IMPROPER HOOK DIRECTION BY  
INTERCHANGING MOTOR LEADS ORANGE (5) & RED (8).  
DO NOT CHANGE PUSHBUTTON WIRING.

**WARNING**  
THIS EQUIPMENT MUST BE EFFECTIVELY GROUNDED  
ACCORDING TO APPLICABLE CODES.

**ADVERTISSEMENT**  
CET EQUIPMENT DOIT ETRE MIS A'LA TERRE EN  
ACCORDANCE AVEC LES NORMES EN VIGUEUR.

### 115V CONNECTIONS, 1 PHASE

333171-01

# 115/230 VOLT RECONNECTABLE, 1 PHASE, SINGLE SPEED HOIST

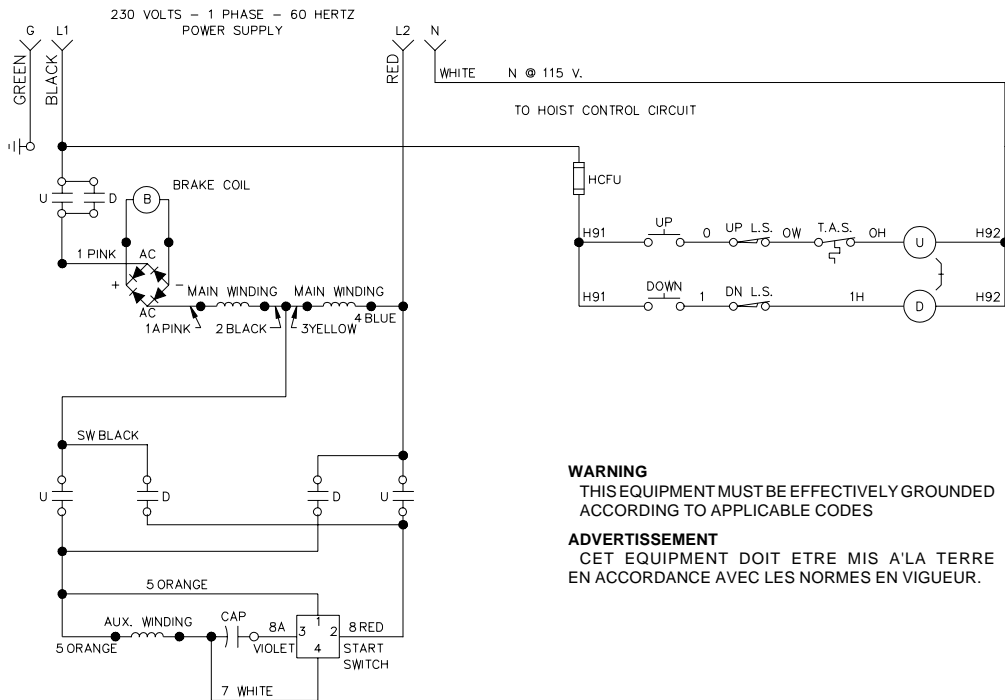

**WARNING**  
THIS EQUIPMENT MUST BE EFFECTIVELY GROUNDED  
ACCORDING TO APPLICABLE CODES

**ADVERTISSEMENT**  
CET EQUIPEMENT DOIT ETRE MIS A LA TERRE  
EN ACCORDANCE AVEC LES NORMES EN VIGUEUR.

333171-02

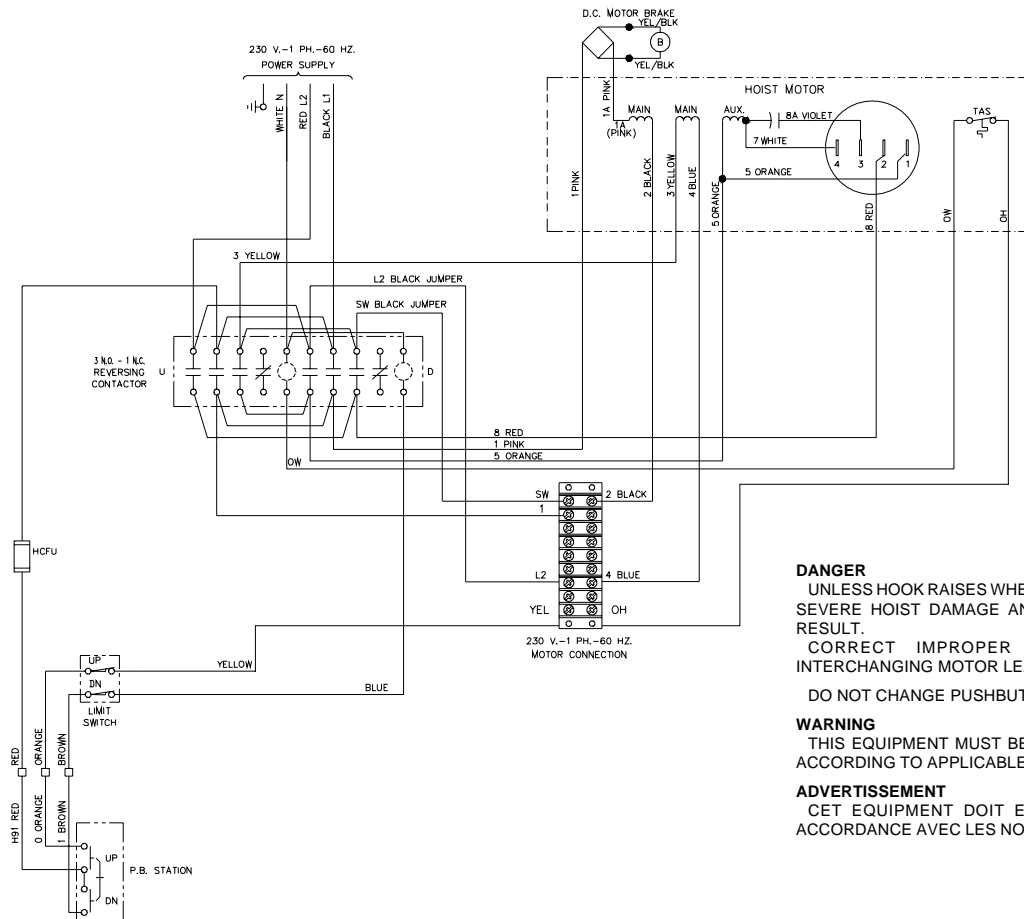

**DANGER**  
UNLESS HOOK RAISES WHEN "UP" BUTTON IS PRESSED  
SEVERE HOIST DAMAGE AND A DROPPED LOAD MAY  
RESULT.  
CORRECT IMPROPER HOOK DIRECTION BY  
INTERCHANGING MOTOR LEADS ORANGE (5) & RED (8).  
DO NOT CHANGE PUSHBUTTON WIRING.

**WARNING**  
THIS EQUIPMENT MUST BE EFFECTIVELY GROUNDED  
ACCORDING TO APPLICABLE CODES.

**ADVERTISSEMENT**  
CET EQUIPEMENT DOIT ETRE MIS A LA TERRE EN  
ACCORDANCE AVEC LES NORMES EN VIGUEUR.

## 230V CONNECTIONS, 1 PHASE

333171-01

# 115/230 VOLT RECONNECTABLE, 1 PHASE, SINGLE SPEED HOIST WITH TRANSFORMER

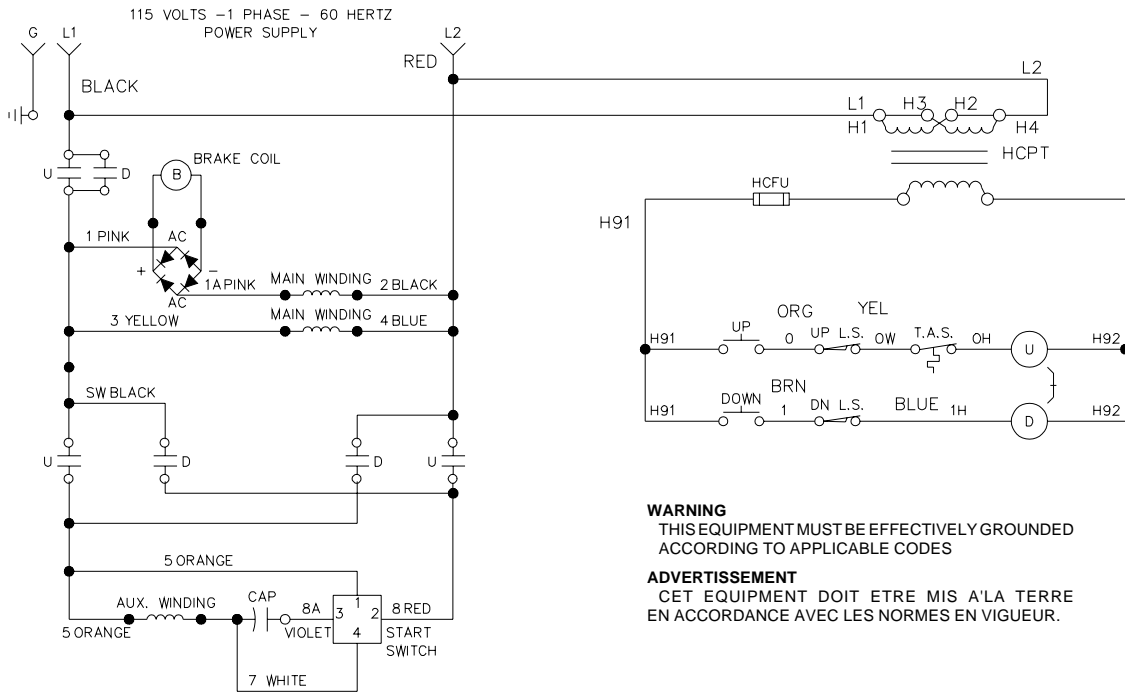

**WARNING**  
THIS EQUIPMENT MUST BE EFFECTIVELY GROUND  
ACCORDING TO APPLICABLE CODES

**ADVERTISSEMENT**  
CET EQUIPMENT DOIT ETRE MIS A'LA TERRE  
EN ACCORDANCE AVEC LES NORMES EN VIGUEUR.

333171-04

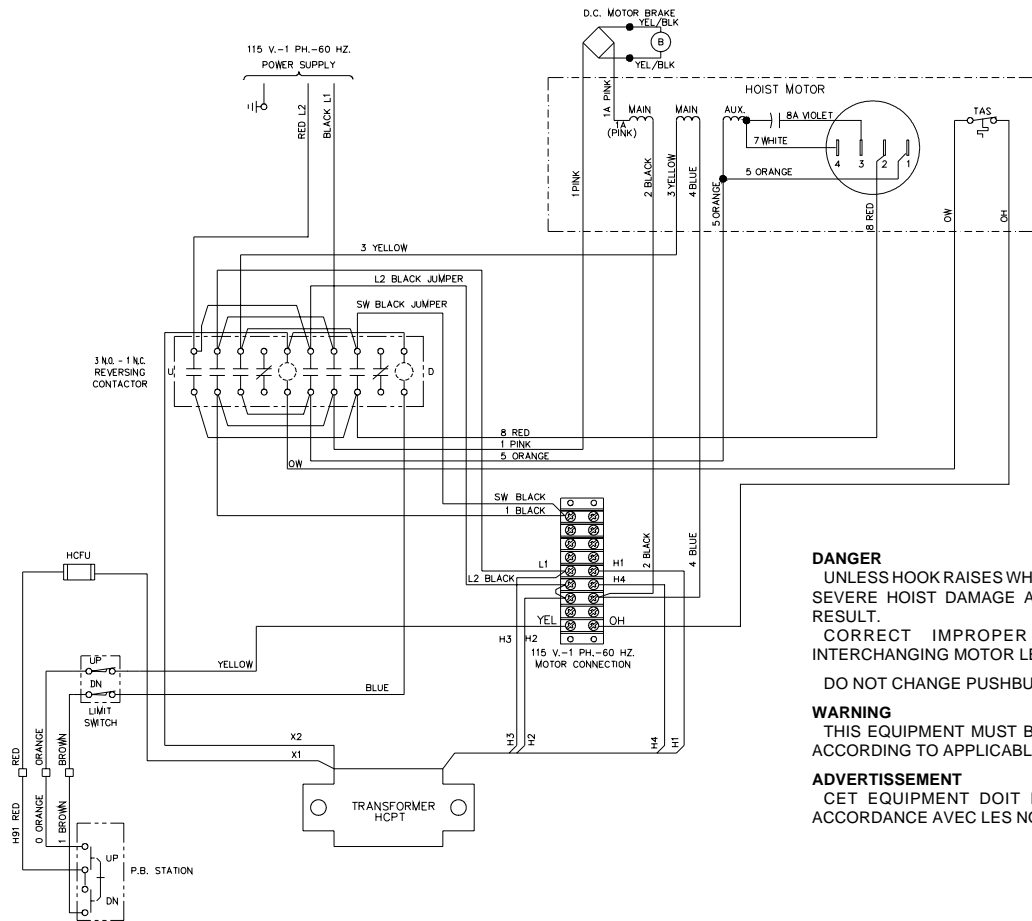

**DANGER**  
UNLESS HOOK RAISES WHEN "UP" BUTTON IS PRESSED  
SEVERE HOIST DAMAGE AND A DROPPED LOAD MAY  
RESULT.  
CORRECT IMPROPER HOOK DIRECTION BY  
INTERCHANGING MOTOR LEADS ORANGE (5) & RED (8).

DO NOT CHANGE PUSHBUTTON WIRING.

**WARNING**  
THIS EQUIPMENT MUST BE EFFECTIVELY GROUND  
ACCORDING TO APPLICABLE CODES.

**ADVERTISSEMENT**  
CET EQUIPMENT DOIT ETRE MIS A'LA TERRE EN  
ACCORDANCE AVEC LES NORMES EN VIGUEUR.

## 115V CONNECTIONS, 1 PHASE

333171-03

# 115/230 VOLT RECONNECTABLE, 1 PHASE, SINGLE SPEED HOIST WITH TRANSFORMER

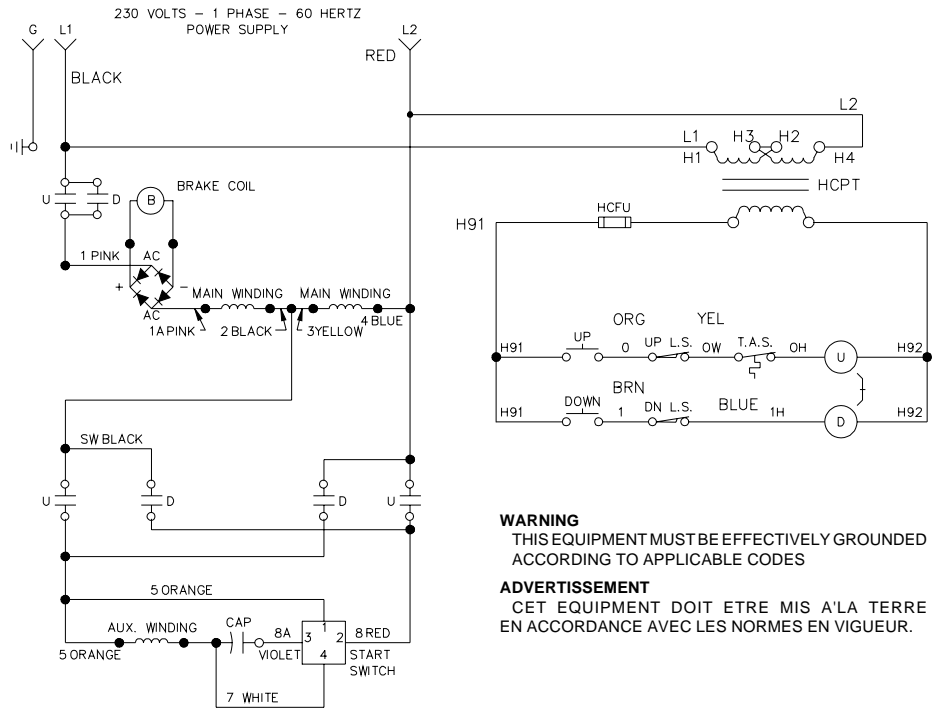

**WARNING**  
THIS EQUIPMENT MUST BE EFFECTIVELY GROUND  
ACCORDING TO APPLICABLE CODES

**ADVERTISSEMENT**  
CET EQUIPMENT DOIT ETRE MIS A'LA TERRE  
EN ACCORDANCE AVEC LES NORMES EN VIGUEUR.

333171-04

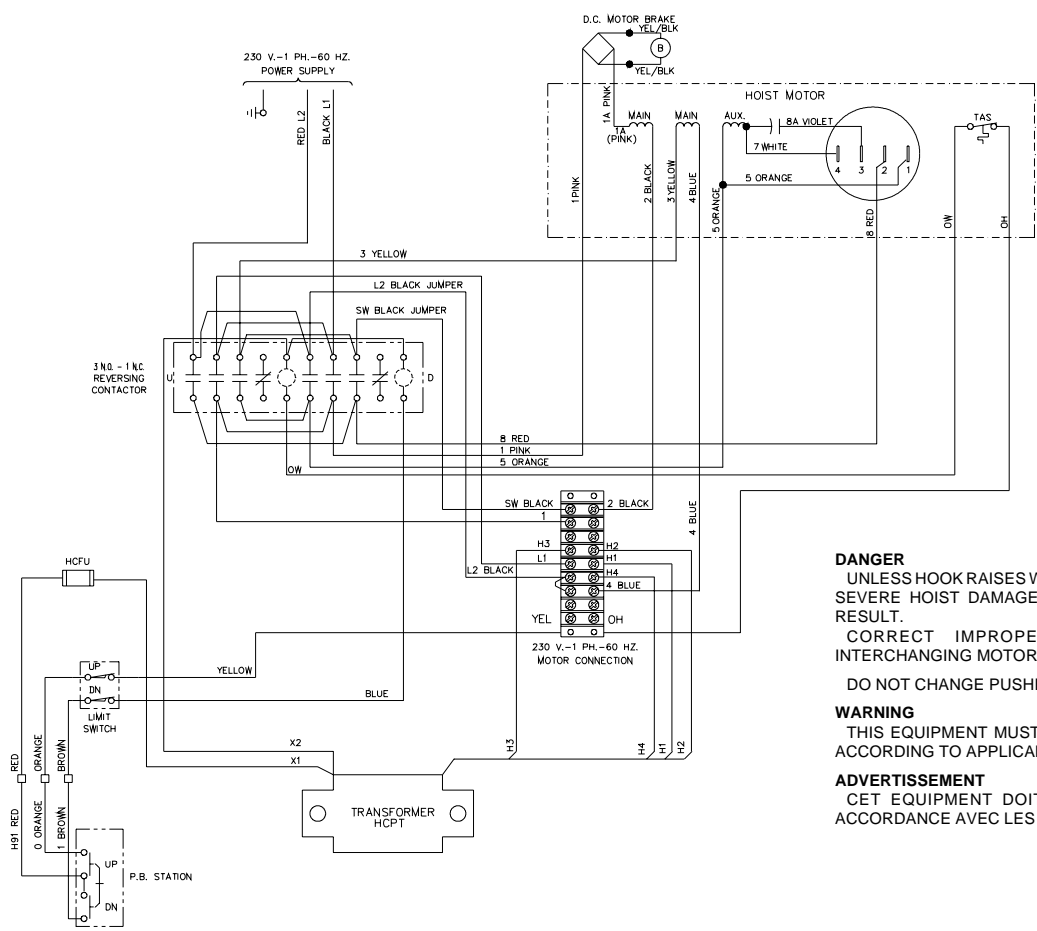

**DANGER**  
UNLESS HOOK RAISES WHEN "UP" BUTTON IS PRESSED  
SEVERE HOIST DAMAGE AND A DROPPED LOAD MAY  
RESULT.  
CORRECT IMPROPER HOOK DIRECTION BY  
INTERCHANGING MOTOR LEADS ORANGE (5) & RED (8).  
DO NOT CHANGE PUSHBUTTON WIRING.

**WARNING**  
THIS EQUIPMENT MUST BE EFFECTIVELY GROUND  
ACCORDING TO APPLICABLE CODES.

**ADVERTISSEMENT**  
CET EQUIPMENT DOIT ETRE MIS A'LA TERRE EN  
ACCORDANCE AVEC LES NORMES EN VIGUEUR.

## 230V CONNECTIONS, 1 PHASE

333171-03

# 230/460 VOLT RECONNECTABLE, 3 PHASE, SINGLE SPEED HOIST

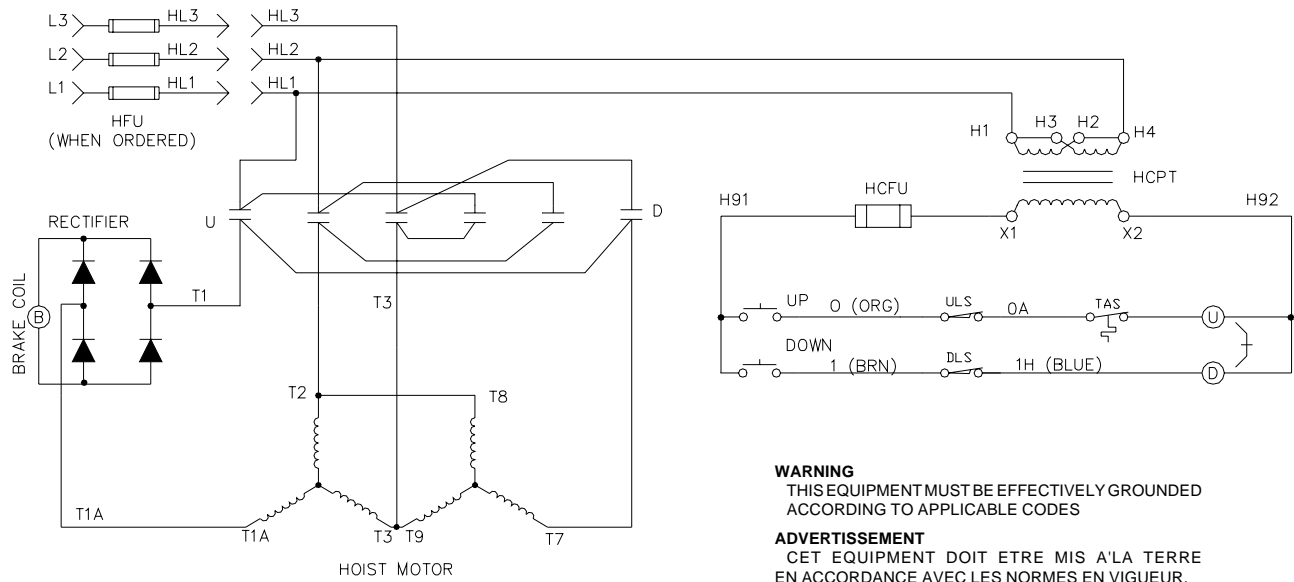

**WARNING**  
THIS EQUIPMENT MUST BE EFFECTIVELY GROUNDED  
ACCORDING TO APPLICABLE CODES

**ADVERTISSEMENT**  
CET EQUIPEMENT DOIT ETRE MIS A'LA TERRE  
EN ACCORDANCE AVEC LES NORMES EN VIGUEUR.

228260-01 REV. 1

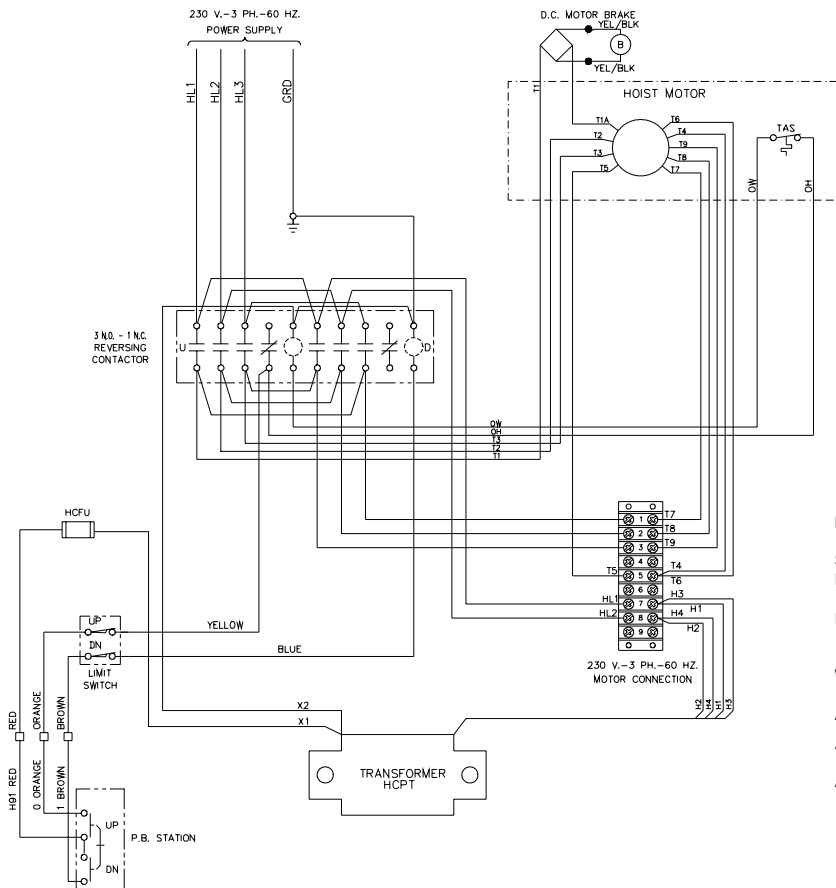

**DANGER**  
UNLESS HOOK RAISES WHEN "UP" BUTTON IS PRESSED  
SEVERE HOIST DAMAGE AND A DROPPED LOAD MAY  
RESULT.

CORRECT IMPROPER HOOK DIRECTION BY  
INTERCHANGING MOTOR LEADS ORANGE (5) & RED (8).

DO NOT CHANGE PUSHBUTTON WIRING.

**WARNING**  
THIS EQUIPMENT MUST BE EFFECTIVELY GROUNDED  
ACCORDING TO APPLICABLE CODES.

**ADVERTISSEMENT**  
CET EQUIPEMENT DOIT ETRE MIS A'LA TERRE EN  
ACCORDANCE AVEC LES NORMES EN VIGUEUR.

## 230V CONNECTIONS, 3 PHASE

333173-01

# 230/460 VOLT RECONNECTABLE, 3 PHASE, SINGLE SPEED HOIST

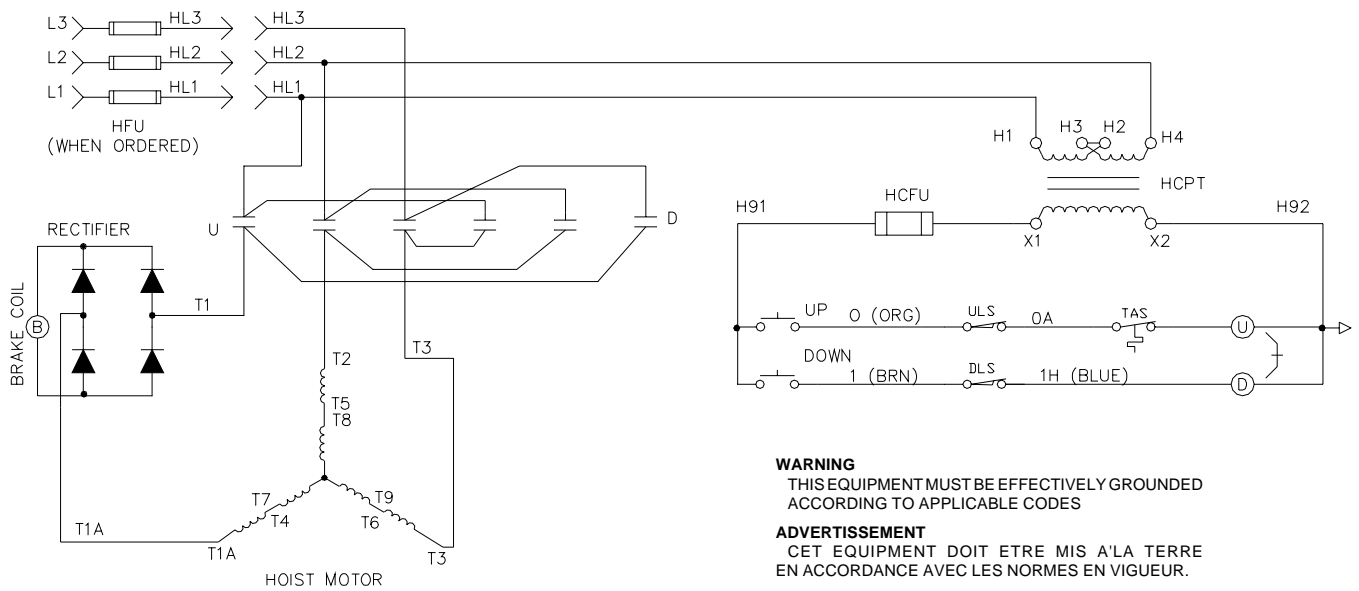

**WARNING**  
THIS EQUIPMENT MUST BE EFFECTIVELY GROUNDED  
ACCORDING TO APPLICABLE CODES

**ADVERTISSEMENT**  
CET EQUIPEMENT DOIT ETRE MIS A'LA TERRE  
EN ACCORDANCE AVEC LES NORMES EN VIGUEUR.

228261-01

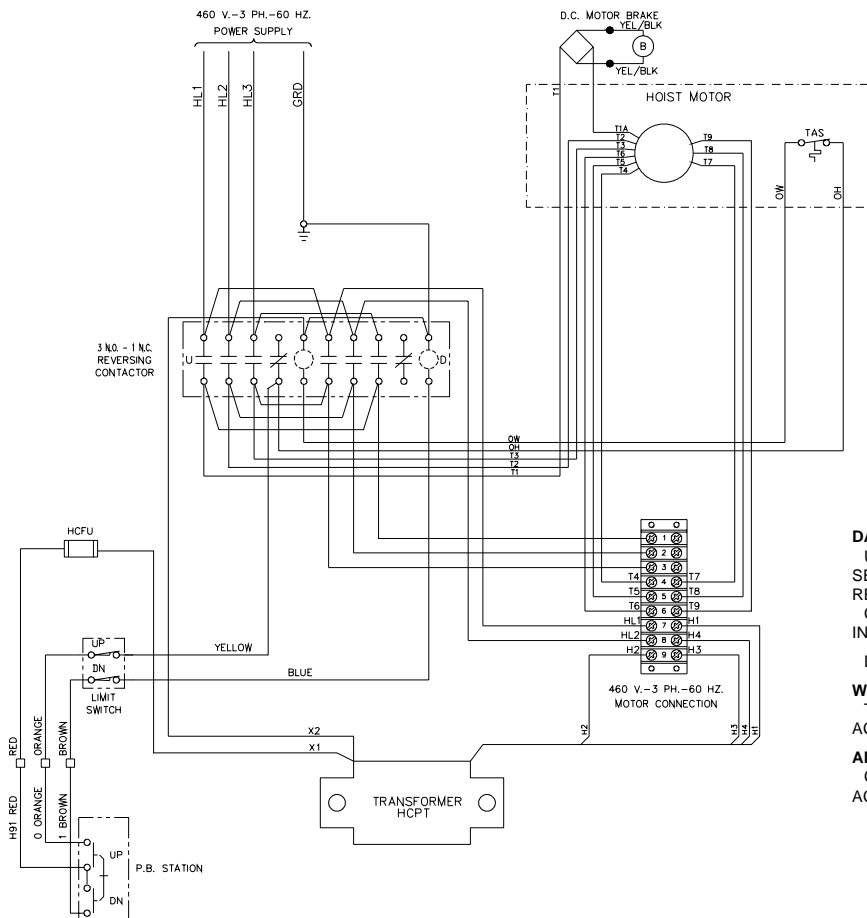

**DANGER**  
UNLESS HOOK RAISES WHEN "UP" BUTTON IS PRESSED  
SEVERE HOIST DAMAGE AND A DROPPED LOAD MAY  
RESULT.  
CORRECT IMPROPER HOOK DIRECTION BY  
INTERCHANGING MOTOR LEADS ORANGE (5) & RED (8).  
DO NOT CHANGE PUSHBUTTON WIRING.

**WARNING**  
THIS EQUIPMENT MUST BE EFFECTIVELY GROUNDED  
ACCORDING TO APPLICABLE CODES.

**ADVERTISSEMENT**  
CET EQUIPEMENT DOIT ETRE MIS A'LA TERRE EN  
ACCORDANCE AVEC LES NORMES EN VIGUEUR.

## 460V CONNECTIONS

333173-02

# SINGLE VOLTAGE, 3 PHASE, SINGLE SPEED HOIST

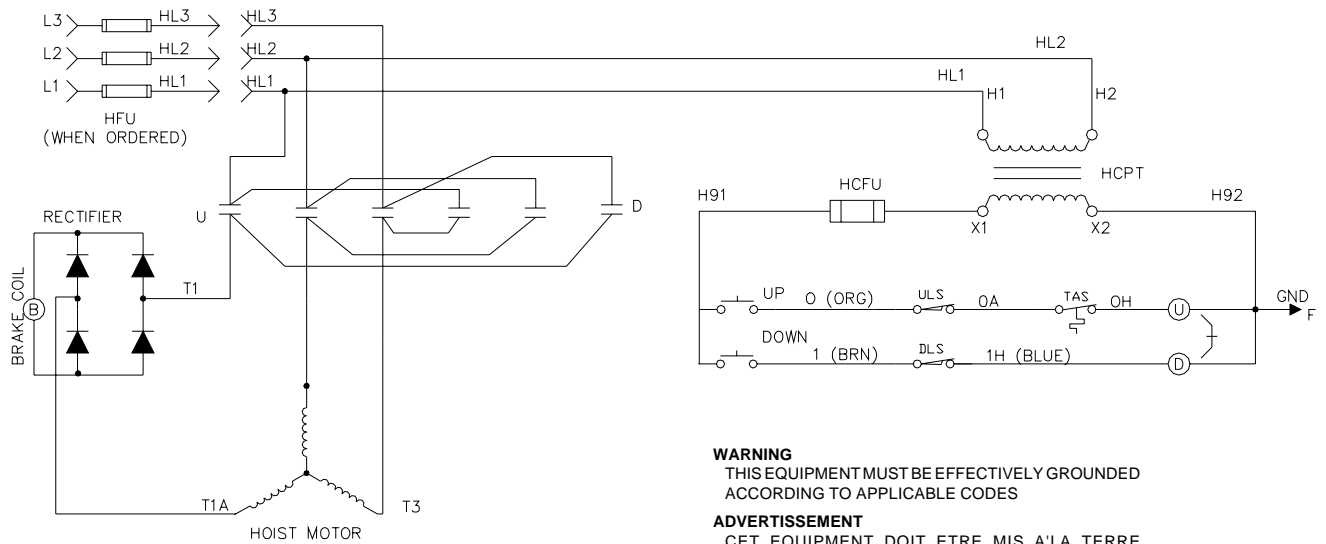

228204-01

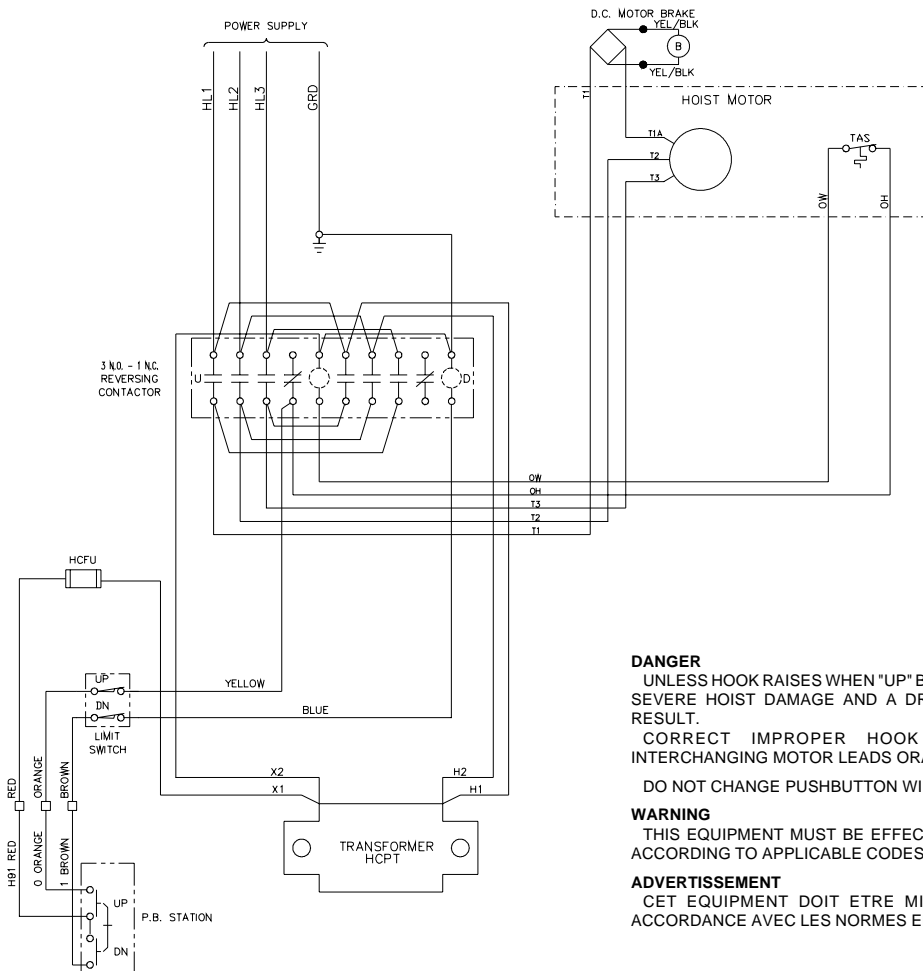

333173-03

# SINGLE VOLTAGE, 3 PHASE, TWO SPEED HOIST

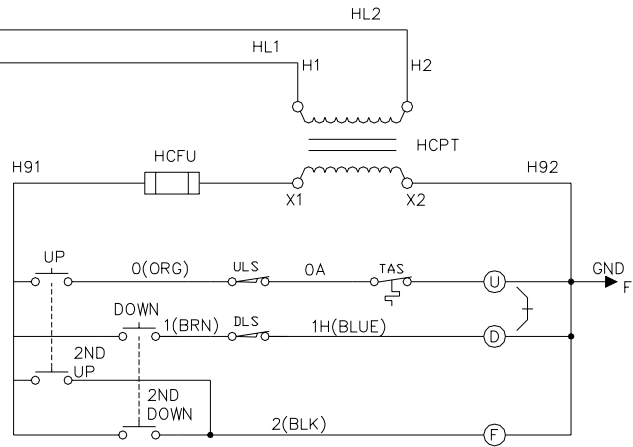
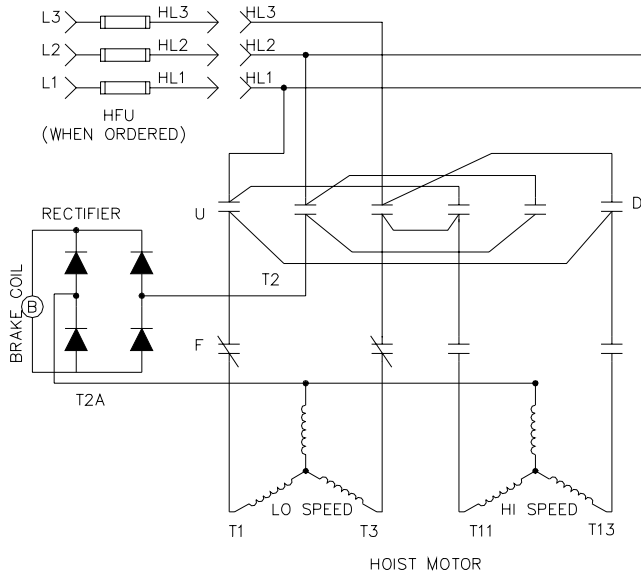

**WARNING**  
THIS EQUIPMENT MUST BE EFFECTIVELY GROUNDED  
ACCORDING TO APPLICABLE CODES

**ADVERTISSEMENT**  
CET EQUIPEMENT DOIT ETRE MIS A'LA TERRE  
EN ACCORDANCE AVEC LES NORMES EN VIGUEUR.

228196-01 REV. 1

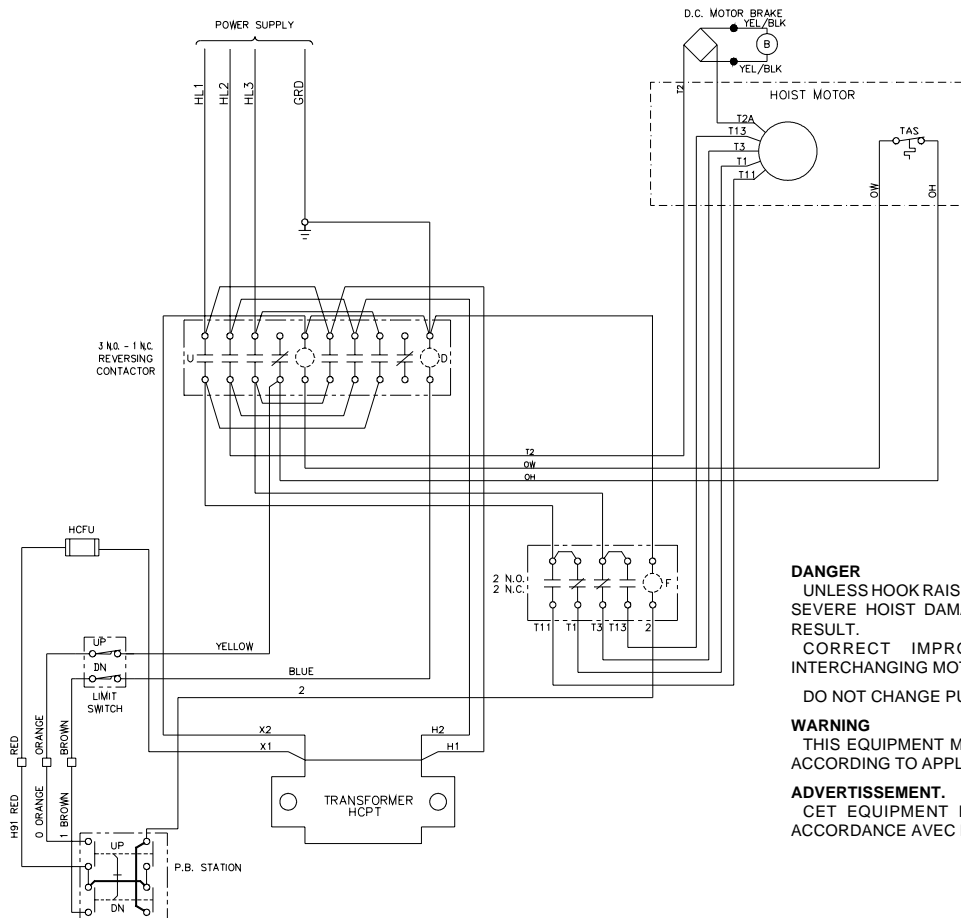

**DANGER**  
UNLESS HOOK RAISES WHEN "UP" BUTTON IS PRESSED  
SEVERE HOIST DAMAGE AND A DROPPED LOAD MAY  
RESULT.  
CORRECT IMPROPER HOOK DIRECTION BY  
INTERCHANGING MOTOR LEADS ORANGE (5) & RED (8).  
DO NOT CHANGE PUSHBUTTON WIRING.

**WARNING**  
THIS EQUIPMENT MUST BE EFFECTIVELY GROUNDED  
ACCORDING TO APPLICABLE CODES

**ADVERTISSEMENT.**  
CET EQUIPEMENT DOIT ETRE MIS A'LA TERRE EN  
ACCORDANCE AVEC LES NORMES EN VIGUEUR.

333173-04